

## An Approach for the conception of Intelligent Control for Torque-Ripple Minimization with Varying Parameters in Electrical Motor Drives

BENDAAS. Ismail<sup>(1)</sup>, NACERI. Farid<sup>(2)</sup> and BOUMAARAF Farid<sup>(3)</sup>

<sup>(1)</sup>Department of Electrical Engineering, Batna University

<sup>(2)</sup>Department of Electrical Engineering, Batna University

<sup>(3)</sup>Department of Electrical Engineering, Batna University

E-Mails: <sup>(1)</sup>s\_bendaas@hotmail.fr, <sup>(2)</sup>nacerifarid@yahoo.fr, farideltb@yahoo.fr

**Abstract**—This paper presents an approach toward the design of a robust control with sliding-mode (SMC) plus y logic control (FLC) for induction motors. As the variations of both control system parameters and operating conditions occur, the conventional control methods may not be satisfied further. Sliding-mode control is robust with respect to both induction motor parameter variations and external disturbances. By embedding a fuzzy logic control into the sliding-mode control, the chattering (torque-ripple) problem with varying parameters, which are the main disadvantage in sliding-mode control, can be suppressed. Simulations results of the proposed control theme present good dynamic and steady-state performances as compared to the classical SMC from aspects for torque-ripple minimization, the quickly dynamic torque response and robustness to disturbance and variation of parameters.

**Key-Words**— Induction motor; sliding mode control, fuzzy logic control, fuzzy sliding mode control, torque-ripple, parameters variation

### I. INTRODUCTION

Induction Motors (IM) are most suitable for industrial drives, because of their simple and robust structure, higher torque-to-weight ratio, higher reliability and ability to operate in hazardous environment. However, their control is a challenging task, because the rotor current, responsible for the torque production, is induced from the stator current and also contributes to net air-gap flux resulting in coupling between torque and flux [12]. The input-output linearization has been frequently used in nonlinear systems to find a direct relation between the system output and input in order to implement a control law. However, the complexity and the presence of high nonlinearities, in some cases do not have an exact compensation of these nonlinearities and thus obtain the desired tracking performance in the presence of external disturbances.

Known by its robustness and simplicity of implementation, the sliding mode has been largely used to control a large class of nonlinear systems, [3], [8], [11], [15]. To define a surface called sliding depending on system states such that it is attractive. The synthesized global control consists of two terms; the first allows the approach to this

surface and the second maintaining sliding along it towards the origin of the phase plane. The global control as well constructed ensures good tracking performance, rapid dynamic and short response time [16].

However, this control law represents a disadvantage in using the sign function in the control law to ensure the passage of the approach phase to the sliding mode. This gives rise to the phenomenon of chattering which consists of sudden and rapid variation of the control signal, which can excite the high frequency of the process and it damaging. A fuzzy logic control has been a subject of active research since the work of Mamdani proposed in 1974 [9], the concept of FLC is to utilize the qualitative knowledge of a system to design a practical controller; it is generally applicable to plants that are ill-modelled, but qualitative knowledge of experienced operators available for design. It is particularly suitable for those systems with uncertain or complex dynamics. In general, a fuzzy control algorithm consists of a set of heuristic decision rules and can be regarded as a nonmathematical control algorithm, in contrast to a conventional feedback control algorithm [17], indeed, to remedy the disadvantage of the chattering phenomenon more works [5], [6], [13]. Have been focused on the combination of sliding mode control with fuzzy logic control

The main objective of this paper proposes the synthesis of nonlinear control law and more precisely, the synthesis of two control strategies, control by sliding mode (SMC) and the sliding mode fuzzy control (FSMC) for application to an induction motor this is used to minimization the torque-ripple with varying parameters. Finally, simulations results and a comparison are presented to demonstrate the contribution of this approach.

### II. MATHEMATIC MODEL OF AN INDUCTION MOTOR

The model of three-phase induction motor in the laboratory frame  $(r, s)$  is given by the following equations:

The voltage equations become:

$$\begin{cases} V_{sr} = R_s i_{sr} + \frac{dW_{sr}}{dt} \\ V_{ss} = R_s i_{ss} + \frac{dW_{ss}}{dt} \\ V_{rr} = 0 = R_r i_{rr} + \frac{dW_{rr}}{dt} + \tilde{S}W_{rs} \\ V_{rs} = 0 = R_r i_{rs} + \frac{dW_{rs}}{dt} - \tilde{S}W_{rr} \end{cases} \quad (1)$$

The expression of electromagnetic torque and the movement for induction motor written as follows:

$$T_e = p \frac{M}{L_r} (W_{rr} i_{ss} - W_{rs} i_{sr}) \quad (2)$$

$$J \frac{d\Omega}{dt} = T_e - T_L - f\Omega \quad (3)$$

The state model of the induction motor is that of a nonlinear system multivariable taking the following form:

$$\dot{x}(t) = f(x) + g(x)u(t) \quad (4)$$

The model of the induction motor, driven by (1), (2) and (3), is defined by the nonlinear system as follows:

$$\frac{d}{dt} \begin{bmatrix} i_{sr} \\ i_{ss} \\ W_{rr} \\ W_{rs} \\ \tilde{S} \end{bmatrix} = \begin{bmatrix} -\dot{x}_{sr} + \frac{K}{T_r} W_{rr} + pK\tilde{S}W_{rs} \\ -\dot{x}_{ss} - pK\tilde{S}W_{rr} + \frac{K}{T_r} W_{rs} \\ \frac{M}{T_r} i_{sr} - \frac{1}{T_r} W_{rr} - p\tilde{S}W_{rs} \\ \frac{M}{T_r} i_{ss} + p\tilde{S}W_{rr} - \frac{1}{T_r} W_{rs} \\ -\frac{f}{J} \tilde{S} - \frac{T_L}{J} \end{bmatrix} + \begin{bmatrix} r & 0 \\ 0 & r \\ 0 & 0 \\ 0 & 0 \\ 0 & 0 \end{bmatrix} \begin{bmatrix} V_{sr} \\ V_{ss} \end{bmatrix} \quad (5)$$

With

$$\dagger = 1 - \frac{M^2}{L_s L_r}, K = \frac{M}{\dagger L_s L_r}, \dot{x} = \frac{1}{\dagger L_s} (R_s + R_r \frac{M^2}{L_r^2}), \tilde{\sim} = \frac{pM}{JL_r}, r = \frac{1}{\dagger L_s}$$

$i_{sr,s}$  : Component of the stator current reference of the stator.

$W_{rr,s}$  : Component of the rotor flux reference of the stator.

$\tilde{S}$  : Angular speed of rotation.

$V_{sr,s}$  : Component of stator voltage reference of the stator.

$R_s, R_r$  : Resistances of stator and rotor windings.

$[L_s]$  : Stator inductances matrix.

$[L_r]$  : Rotor inductances matrix.

$[M]$  : Matrix of stator-rotor mutual inductances.

$p$  : Number of pole pair.

$J$  : The moment of inertia.

$f$  : The friction coefficient.

$\dagger$  : The dispersion coefficient of Blondel.

$T_e$  : The electromagnetic torque.

$T_L$  : The load torque.

$\Omega$  : Mechanical speed of rotation of the rotor.

### III. BASIC CONCEPTS OF VSC

Variable structure systems are characterized by the choice of a function and a switching logic. This choice will switch at any time between the different structures, combining the useful properties of each of these structures in order to have the desired behavior of the system. Consider the system described by (4). [2], [4], [10].

The VSC design consists in achieving the following steps:

1) Design a switching manifold  $s$  in the state space to represent a desired system dynamics, which is of lower order than the dimension of the given plant;  $s$  is defined by

$$s = \{x \in \mathfrak{R}^n : s(x) = 0\} \quad (6)$$

Where  $s(x) \in \mathfrak{R}^n$  is called the switching function.

2) Design a variable structure control

$$u = \begin{cases} u_{\max}^+(x) & \text{Si } s(x) > 0 \\ u_{\min}^-(x) & \text{Si } s(x) < 0 \end{cases} \quad (7)$$

Such that any state  $x$  outside the switching surface is driven to reach this surface in finite time, that is, the condition  $s(x) = 0$  is satisfied in finite time. Once on the switching surface, the sliding mode takes place, following the desired system dynamics. This procedure makes the VSC system globally asymptotically stable [15].

Equation (6) is a variety of sliding that divides the state space into two disjoint  $s(x) > 0$  and  $s(x) < 0$ .

The switching logic is designed to abuse the trajectory to follow the surface switching. We then say that the trajectory of the system sliding along the surface switching  $s(x) = 0$  and is referred to the phenomenon of chattering [8], [13], [15].

So we are interested in calculating the equivalent control and then to calculate the attractive control defined in the state space (4), the control vector  $u$  is composed of two parameters  $u_{eq}$  and  $\Delta u$  must be found the analytical expression of the control  $u(t)$

expression of the control  $u(t)$

We have:

$$\dot{s}(x) = \frac{ds}{dt} = \frac{\partial s}{\partial x} \frac{dx}{dt} = \frac{\partial s}{\partial x} \{f(x,t) + g(x,t)u_{eq}(t)\} + \frac{\partial s}{\partial t} \{g(x,t)\Delta u\} \quad (8)$$

During the sliding mode and the system standing, the surface is zero and therefore its derivative and discontinuous part are zero. Hence, we deduce the expression of the equivalent control:

$$u_{eq}(t) = -\left\{ \frac{\partial s}{\partial t} g(x,t) \right\}^{-1} \left\{ \frac{\partial s}{\partial x} f(x,t) \right\} \quad (9)$$

For the equivalent control can take a finite value,

$$\text{must } \frac{\partial S}{\partial x} \cdot g(x,t) \neq 0.$$

During the convergence mode and replacing the equivalent control by its expression in (8), we find the new expression of the derivative of the surface:

$$\dot{s}(x) = \frac{\partial s}{\partial x} \{g(x, t) \Delta u\} \quad (10)$$

The problem is to find  $\Delta u$  such that:

$$s(x) \dot{s}(x) = s(x) \frac{\partial s}{\partial x} \{g(x, t) \Delta u\} < 0 \quad (11)$$

The simplest form that can take the discrete control is a relay. In this case the attractive control is as follows:

$$\Delta u = -k \text{sign}(s(x, t)) \quad (12)$$

Substituting (12) into (11), we obtain:

$$s(x) \dot{s}(x) = \frac{\partial s}{\partial t} g(x, t) k |s(x)| < 0 \quad (13)$$

It is necessary that  $\frac{\partial s}{\partial t} g(x, t) k |s(x)| < 0$  to satisfy the conditions of attractiveness of the sliding surface. The gain  $k$  is chosen to satisfy the positive condition (13). The choice to gain great influence because it is very small response time is very long, and if chosen very large, we will have large oscillations at the organ of the control. These oscillations can excite the dynamics disregarded (the phenomenon of chattering) [3], [16].

#### IV. DESIGN OF FUZZY SLIDING MODE CONTROLLER

The approach of the sliding mode control is based on the discontinuous function of state variables in the system that is used to create a "sliding surface". When this surface is reached, the discontinuous function guarded the trajectory on the surface of such so that the desired system dynamics is obtained [1], [14], [15].

In this paper, the regulators of speed and rotor flux are substituted by a fuzzy sliding mode control to obtain a robust performance. One part of the equivalent control (SMC) and part of fuzzy control (FLC) are contained in this hybrid control (FSMC) as show in fig. (1)[17].

$$u_{FSMC} = u_{eq} + u_{fuzzy} \quad (14)$$

The two parts are combined to provide stability and robustness of the system, the method of control by fuzzy logic approach is adopted to solve the problem of Chattering.

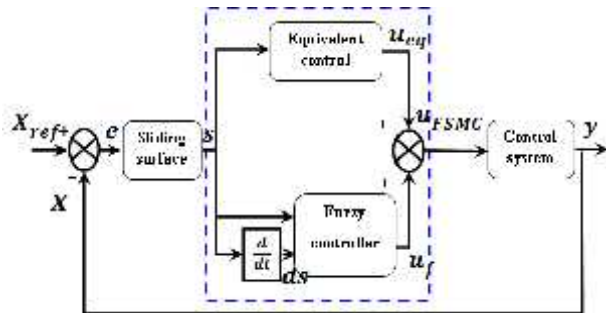

Fig. (1): Diagram of the hybrid control FSMC

#### A. Synthesis of the sliding mode control

In the design of sliding mode control of speed and rotor flux of the system, the switching function is chosen as follows [3]:

$$\begin{cases} s_1 = k_1 e_s + \dot{e}_s \\ s_2 = k_2 e_{w_r} + \dot{e}_{w_r} \end{cases} \quad (15)$$

With:

$$\begin{cases} e_s = \tilde{S} - \tilde{S}_{ref} \\ e_{w_r} = W_r - W_{rref} \end{cases} \quad (16)$$

Beginning with the replacement of (16) into (15) we have:

$$\begin{cases} s_1 = k_1 (\tilde{S} - \tilde{S}_{ref}) + (\dot{\tilde{S}} - \dot{\tilde{S}}_{ref}) \\ s_2 = k_2 (W_r - W_{rref}) + (2W_{r\dot{r}} \dot{W}_{r\dot{r}} + 2W_{r\dot{s}} \dot{W}_{r\dot{s}} - \dot{W}_{rref}) \end{cases} \quad (17)$$

After substitution of (18) and (5) we arrive at:

$$\begin{cases} s_1 = \frac{k_1}{J} (\tilde{S} - \tilde{S}_{ref}) + (i_{s\dot{s}} W_{r\dot{r}} - i_{s\dot{r}} W_{r\dot{s}}) - \frac{T_L}{J} \tilde{S}_{ref} \\ s_2 = \frac{T_r}{2} k_2 (W_r - W_{rref}) + [M(i_{s\dot{r}} W_{r\dot{r}} + i_{s\dot{s}} W_{r\dot{s}}) - W_r] - \frac{T_r}{2} \dot{W}_{rref} \end{cases} \quad (18)$$

$k_1$  and  $k_2$  are positive gains.

The development of derivatives calculated of the surfaces give:

$$\begin{cases} \dot{s}_1 = (k_1 - \frac{1}{T_r} - \chi) f_2 - k_1 \frac{T_L}{J} - p \tilde{S} (f_1 + K W_r) - k_1 \dot{\tilde{S}}_{ref} - \dot{\tilde{S}} \\ \quad + r W_{r\dot{s}} V_{s\dot{r}} - r W_{r\dot{r}} V_{s\dot{s}} \\ \dot{s}_2 = \frac{2}{T_r} (\frac{T_r k_2}{2} - 1) \dot{W}_r + \frac{2M}{T_r} (\frac{M}{T_r} f_3 - (\frac{1}{T_r} + \chi) f_1 + \frac{K}{T_r} W_r + p \tilde{S} f_2) \\ \quad - k_2 \dot{W}_{rref} - \ddot{W}_{rref} + \frac{2r}{T_r} M W_{r\dot{s}} V_{s\dot{s}} + \frac{2r}{T_r} M W_{r\dot{r}} V_{s\dot{r}} \end{cases} \quad (19)$$

With:

$$\begin{cases} f_1 = i_{s\dot{r}} W_{r\dot{r}} + i_{s\dot{s}} W_{r\dot{s}} \\ f_2 = i_{s\dot{s}} W_{r\dot{r}} + i_{s\dot{r}} W_{r\dot{s}} \\ f_3 = i_{s\dot{r}}^2 + i_{s\dot{s}}^2 \end{cases} \quad (20)$$

The necessary condition for the system states follow the trajectory defined by the sliding surfaces is  $s_i = 0$ , the equivalent part  $u_{eq}$  is the control to providing  $\dot{s} = 0$  for the nominal system  $\dot{s} = 0$  give:

$$\begin{cases} (k_1 - \frac{1}{T_r} - \chi) f_2 - k_1 \frac{T_L}{J} - p \tilde{S} (f_1 + K W_r) - \frac{k_1}{J} \dot{\tilde{S}}_{ref} - \frac{1}{J} \dot{\tilde{S}} \\ = r W_{r\dot{s}} V_{s\dot{r}} - r W_{r\dot{r}} V_{s\dot{s}} \\ (\frac{T_r k_2}{2} - 1) \dot{W}_r + M (\frac{M}{T_r} f_3 - (\frac{1}{T_r} + \chi) f_1 + \frac{K}{T_r} W_r + p \tilde{S} f_2) \\ - \frac{T_r}{2} k_2 \dot{W}_{rref} - \frac{T_r}{2} \ddot{W}_{rref} = r M W_{r\dot{s}} V_{s\dot{s}} + r M W_{r\dot{r}} V_{s\dot{r}} \end{cases} \quad (21)$$

Assume:

$$\begin{cases} A = (k_1 - \frac{1}{T_r} - x)f_2 - k_1 \frac{T_L}{J} - p\dot{S}(f_1 + Kw_r) - \frac{k_1}{s} \dot{S}_{ref} - \frac{1}{s} \dot{S} & (22) \\ B = (\frac{T_r k_2}{2} - 1)W_r + M(\frac{M}{T_r} f_3 - (\frac{1}{T_r} + x)f_1 + \frac{K}{T_r} W_r + p\dot{S}f_2) \\ - \frac{T_r}{2} k_2 \ddot{W}_{ref} - \frac{T_r}{2} \ddot{W}_{ref} \end{cases}$$

Or:

$$\dot{s} = 0 \Rightarrow \begin{bmatrix} A \\ B \end{bmatrix} = \begin{bmatrix} -rW_{rs} & rW_{rR} \\ rMW_{rR} & rMW_{rs} \end{bmatrix} \begin{bmatrix} V_{sR} \\ V_{sS} \end{bmatrix} \quad (23)$$

We have

$$F = \begin{bmatrix} A \\ B \end{bmatrix} \text{ and } \Rightarrow \begin{bmatrix} V_{sR} \\ V_{sS} \end{bmatrix} = -E^{-1} F = u_{eq} \quad (24)$$

### B. Design of fuzzy logic control

It is well known as one of the disadvantages of the SMC is the phenomenon of Chattering. In this section, a fuzzy control FLC is introduced to replace the function  $K_{1,2} \text{sign}(s_{1,2})$ , such kinds that the trajectory of state can reach and move on along the surface of change, a good dynamic steady state can be achieved by the combination of SMC and FLC [11], [14].

The fuzzy controller used in this paper is two inputs and one output.

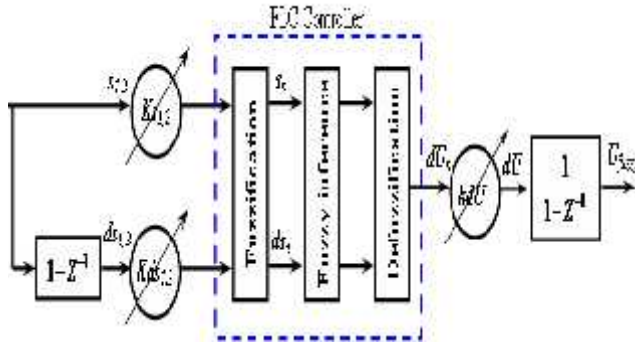

Fig. (2): Diagram of the FLC

The membership functions are defined in Fig. (3a) and Fig. (3b). the fuzzy rule base consists of a collection of linguistic rules of the form [7], [11]:

Rule 1: if  $s_{1,2}$  is NG and  $ds_{1,2}$  is NG then  $dU_{1,2}$  is NG

Rule 2: if  $s_{1,2}$  is NM and  $ds_{1,2}$  is NG then  $dU_{1,2}$  is NG

Rule 3: if  $s_{1,2}$  is NP and  $ds_{1,2}$  is NG then  $dU_{1,2}$  is NG

⋮  
⋮  
⋮

Rule 49: if  $s_{1,2}$  is PG and  $ds_{1,2}$  is PG then  $dU_{1,2}$  is PG

These inferences can be made in a more explicit form of a table, called decision table [9].

TABLE I: TABLE OF FUZZY DECISION (INFERENCE)

$dU_{1,2}$		$ds_{1,2}$							
		NG	NM	NP	EZ	PP	PM	PG	
$s_{1,2}$	NG	NG	NG	NG	NM	NP	NP	NP	EZ
	NM	NG	NM	NM	NM	NP	NP	EZ	PP
	NP	NG	NM	NP	NP	EZ	PP	PM	PM
	EZ	NG	NM	NP	EZ	PP	PP	PM	PG
	PP	NM	NP	EZ	PP	PP	PM	PM	PG
	PM	NP	EZ	PP	PM	PM	PM	PM	PG
	PG	EZ	PP	PP	PM	PG	PG	PG	PG

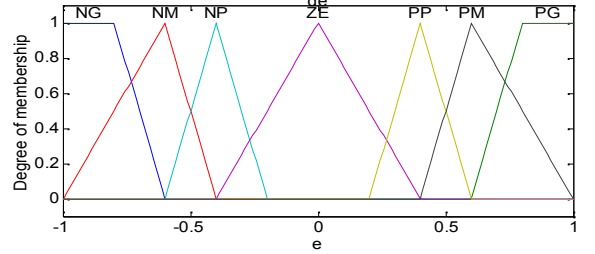
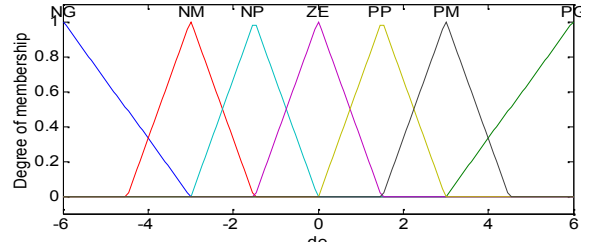

Fig. (3a): membership function of input

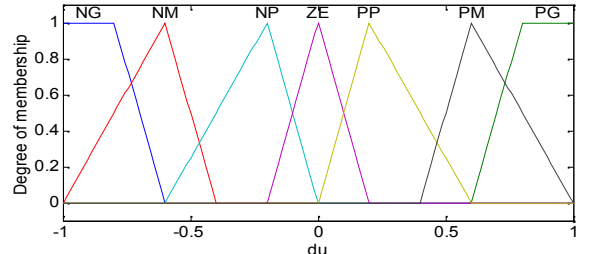

Fig. (3b): membership function of output

Fig. (3): Diagram of the FLC

## V. RESULTS OF SIMULATION AND INTERPRETATIONS

To conclude on the performance of the use of a control using the principle of a hybrid control by fuzzy sliding mode, we will present simulations of an induction motor controlled by a voltage inverter. This performance was established from the simulation of operating modes: robustness of the control relative to parametric variations (stator and rotor resistances) and variation of inertia follows by a variation of a load torque



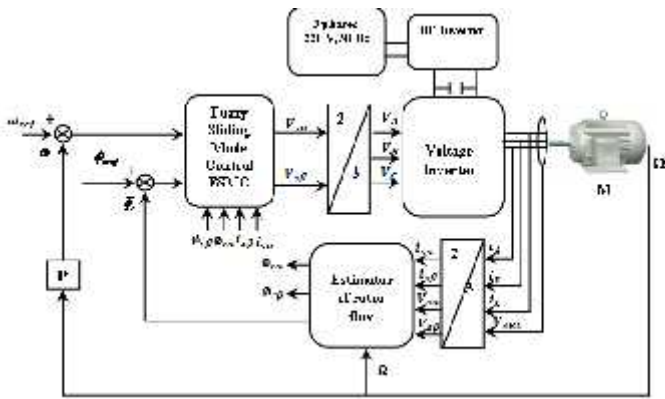

Fig. (4): Block diagram of the proposed FSMC

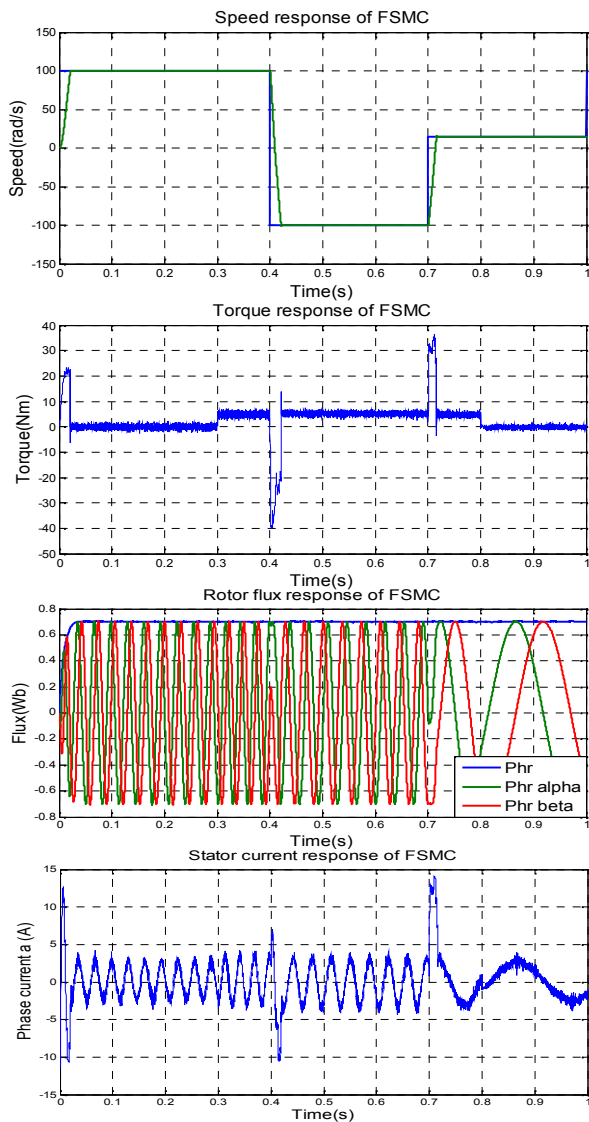

Fig. (5): Simulation results under different's speed references with application a load torque

To show the robust fuzzy sliding mode performances we have simulated the system described in Fig. (4). The first test concerns the speed evolution and the disturbance rejection of FSMC and SMC controllers. This test is related to the performances of the drive system at low reference speed. When the induction motor is operated at 100 rad/sec under no load and a load torque 5 N.m is suddenly applied at  $t=0.3$  s, followed by a consign inversion -100 rad/sec at  $t=0.4$  s and accelerate again to 15 rad/sec. When the induction motor operates in low speed we eliminate the torque load in  $t=0.8$  s. This approach shows clearly that the FSMC gives good performances, rejects the load disturbance very rapidly with no overshoot, with a negligible steady state error, maintain the decoupling between a torque-flux and reduce the torque-ripple phenomenon

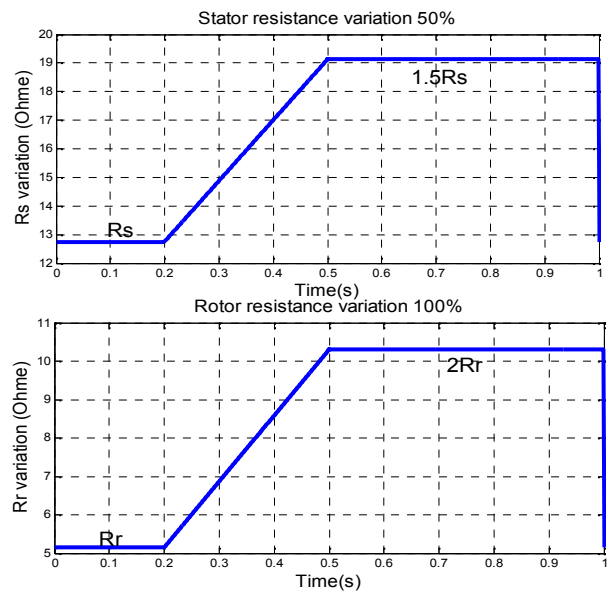

Fig. (6): Stator and rotor resistances variations

In order to test the robustness of the used approach we have studied the effect of the parameters uncertainties on the performances and we compared with the SMC control. To show the effect of the parameters uncertainties, we have simulated the system with different values of the parameter considered and compared to nominal value. Two cases are considered:

1. The stator and rotor resistances (50% and 100% respectively) as show in fig. (6).
2. The moment of inertia (50% to 100%).

To illustrate the performances of control, we have simulated the starting mode of the motor without load, and the application of the load  $T_L=5$  Nm at  $t_1=0.3$  s and it's elimination at  $t_2=0.7$  s, in presence of the variation of parameters considered (the moment of inertia, the stator and rotor resistances) with speed step of 100 rad/sec.

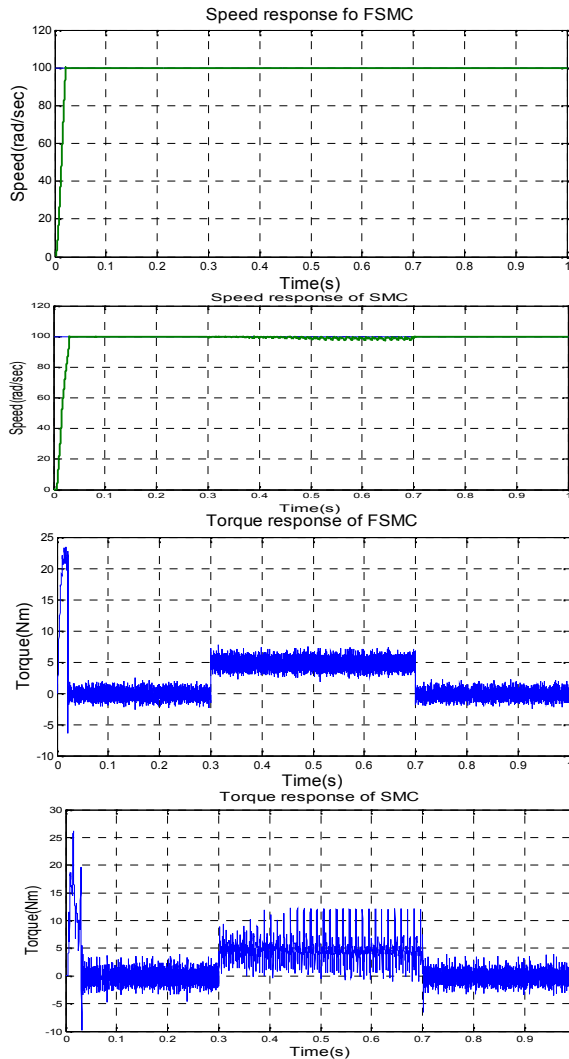

Fig. (7): Results simulation under stator and rotor resistances variation.

Fig. (7) shows the system response realized with the SMC and FSMC for different values of stator and rotor resistances. Fig. (8) shows the tests of robustness realized with the SMC and FSMC for different values of the moment of inertia. For the robustness of control, a variation of the moment of inertia  $J$ , the stator and rotor resistances doesn't have any effects on the performances of the approach used, in the SMC control the torque-ripple phenomenon increases during the load period

### III. CONCLUSION

The paper describes a new approach to robust control for induction motor. It's develops a simple robust controller to deal with parameters uncertain and external disturbances. The control strategy is based on SMC and FLC approaches. The FSMC has the advantage in handling the torque-ripple phenomenon and in reducing the number of the fuzzy rules. The simulation results show that the proposed controller is

superior to SMC in minimization torque-ripple with varying parameters and with higher tracking precision. It appears from the response properties that it has a high performance in presence of the plant parameters uncertain and load disturbances. It is used to control system with unknown model. The FSMC control gives fast dynamic response with no overshoot and zero steady-state error. The decoupling between torque-flux is verified.

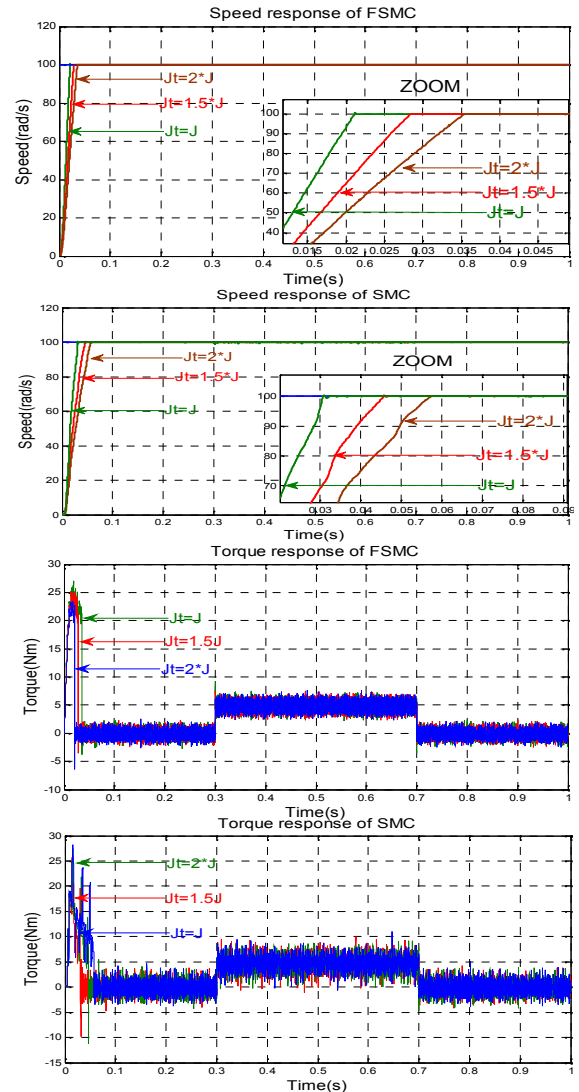

Figure (8): Results simulation under variations of inertia.

### REFERENCES

- [1] M. S. Agamy "Sliding Mode Control of Induction Motors With Minimized Control Effort: Comparative Study," IEEE CCECE/CCGEI, Saskatoon, pp. 2237- 2240 May 2005.
- [2] S. Asif, M. F. LEONID and S.SARAH "Variable Structure Systems from principles to implementation," The Institution of Engineering and Technology, Control engineering series no. 66, pp 245-262, 2004.



# The INTERNATIONAL CONFERENCE ON ELECTRONICS & OIL: FROM THEORY TO APPLICATIONS

March 05-06, 2013, Ouargla, Algeria



- [3] A.Benchaib, A.Rachid and E.Audrezet "Sliding Mode Input–Output Linearization and Field Orientation for Real-Time Control of Induction Motors," IEEE transactions on power electronics, vol. 14, no. 1, pp. 3 – 13, January 1999.
- [4] R. Benayache "Contribution `A La Commande Robuste Des Systèmes Non Linéaires Incertains : Application A Un Système Hydraulique," thèse doctorat à l'université de Valenciennes et du Hainaut Cambrésis, 2009.
- [5] L. Chih-Min and H. Chun-Fei "Adaptive Fuzzy Sliding-Mode Control for Induction Servomotor Systems," IEEE Transactions On Energy Conversion, Vol. 19, no. 2, pp. 362 - 368, June 2004.
- [6] H.F. Ho, K.W.E. Cheng "Position Control of Induction Motor using Indirect Adaptive Fuzzy Sliding Mode Control," IEEE 3rd International Conference on Power Electronics Systems and Applications, pp. 1 - 5 , May 2009.
- [7] F.J. Lin, D.H. Wang and P.K. Huang "FPGA-Based Fuzzy Sliding-Mode Control for a Linear Induction Motor Drive," IEE Proc.-Electr. Power Appl., Vol. 152, No. 5, pp. 1137–1148, September 2005.
- [8] A. Lufi, M. Ghariani and R. Neji "Sliding Mode Control of the Nonlinear Systems," IEEE Xlth International Workshop on Symbolic and Numerical Methods, Modeling and Applications to Circuit Design (SM2ACD) 2010.
- [9] MINH. TA CAO "Commande numérique de machines asynchrones par logique floue," thèse de Philosophie doctorat faculté des études supérieures de l'université Laval 1997.
- [10] W. Perruquetti, J.P. Barbot "Sliding Mode Control In Engineering," Marcel Dekker, inc. 2002.
- [11] W. Rong-Jong, S. Kuo-Ho and T. Chun-Yen "Implementation of Adaptive Enhanced Fuzzy Sliding-Mode Control for Indirect Field-Oriented Induction Motor Drive," IEEE the IEEE International Conference on Fuzzy Systems, vol. 2, pp. 1440 – 1445, May 2003.
- [12] Kanungo Barada Mohanty "Development Of Fuzzy Sliding Mode Controller For Decoupled Induction Motor Drive" PARITANTRA Vol. 8, No.1, pp.33-39 August 2003.
- [13] P. Vidal "Commande Non-Linéaire D'une Machine Asynchrone A Double Alimentation," thèse doctorat à l'institut national polytechnique de Toulouse, 2004.
- [14] Zhao Junhui, Wang Mingyu, Li Yang, Zhou Yanjing and Liu Shuxi "The Study on the Constant Switching Frequency Direct Torque Controlled Induction Motor Drive with a Fuzzy Sliding Mode Speed Controller," IEEE the Natural Science Foundation of Chongqing (CSTC 2007BB3169), pp. 1543-1548, 2007.
- [15] M. Ben Ghalia, and Ali T. Alouani "Knowledge-Based Robust Control of Complex Systems," Systems, Man and Cybernetics, 1995. Intelligent Systems for the 21st Century. IEEE International Conference, vol.2, pp. 977 – 982, October 1995.
- [16] A. Hussain "Contribution A La Commande Adaptative Robuste Par Modes Glissants," Thèse de Doctorat université de Reims Champagne Ardenne, 2009.
- [17] Abdel G. AISSAOUI, Hamza ABID and Mohamed ABID "Robust fuzzy sliding mode controller design For motors drives" Acta Electrotechnica et Informatica Vol. 9, No. 2, pp.64–71,2009.