

:

.

-

.

-

"

" "

" "

"

:

-

;(1)

performance

-1

/

:

■

(processus)

(action)

■

■

)

:

.(

)

(

:

.(2)

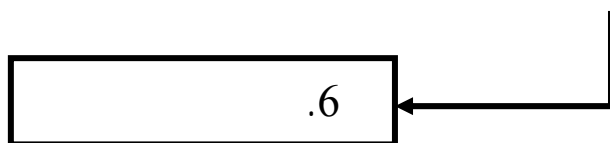
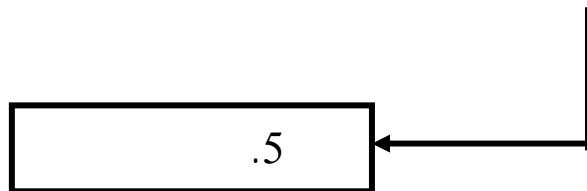
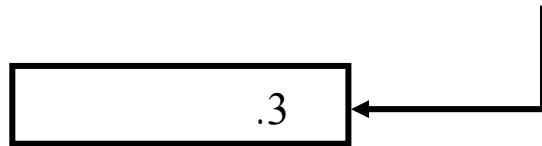
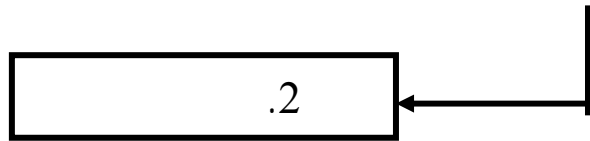
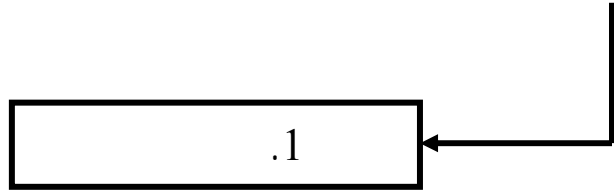

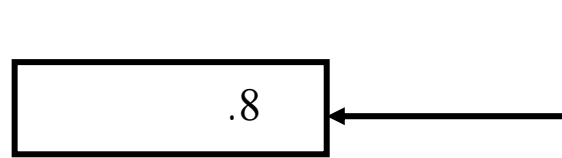
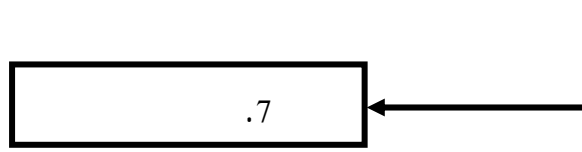

: -
: -1

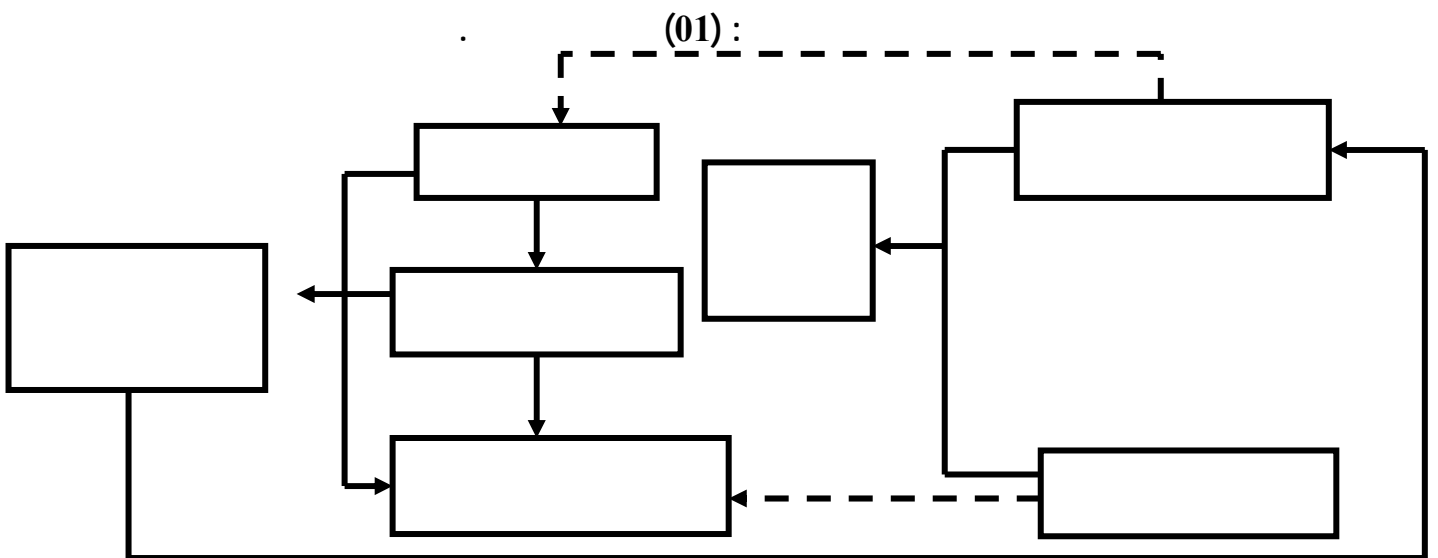

39 : 1998

/ /

:

■
■

-
-
-
-
-
-
-
-
-
-

-2

:kaizen

-

Kaizen

.(3)

-
-
-
-
-

) :
(

) (

●

:(4)

///

-
-
-

()

●

:

)

(....

:(5)

-
-

()

(....)

: Reengineering .1

(6) -

()

-
-
-

:

:(01)

<p style="text-align: center;">+</p>	<p style="text-align: center;">()</p>

. 307 2000

:

:

-3

;(8)

:

(1

:

(2

:

(3

:

(4

· : (5

· : (6

· : (7

· : (8

· : (9

· : **(10**

· : :

· : **.1**

· (9

-1

-2

-3

-4

-5

-6

-7

-8

-9

· : -2

· (10

■

■

■

■

■

· : -3

.(11)

-
-
-
-

.

:

: (02)

-	-	-
-	-	-
-	-	-
-	-	-
-	-	-
-	-	-
-	-	-
-	-	-
-	-	-
% 90	-	-
-	-	-

. 312-309

:

:

(% 85 %75)

- 1- Bourguignon – A « performance et contrôle de gestion , encyclopédie de comptabilité , contrôle de gestion et audit , sous la direction de : Bernard celasse, économisa , janvier 2000 , artic le 70, p :932.
- . 35-33: 1998 -2
- . 93-92 -3
- .37: 1999 -4
- 149– 141 -5
- . 227 1998 -6
- . 304– 303 : 2000 -7
- 8- (07/01/2005) , (http://www.aue.gov.ae/mofi/arabic/a_isooperation.htm)
- " " : -9
- (<http://www.awatan-news-com /data/2005 01 08/index.asp ?conte=writer2>)
- .111 -11

	:	
1998		-
.1999		-
.1998		-
. 2000		-
"	"	:
		-

(<http://www.awatan-news-com /data/2005 01 08/index.asp ?conte=writer2>)

8- (07/01/2005) , (http://www.aue.gov.ae/mofi/arabic/a_isooperation.htm)

1- Bourguignon – A « performance et contrôle de gestion , encyclopédie de comptabilité , contrôle de gestion et audit , sous la direction de : Bernard celasse, économisa , janvier 2000 , artic le 70
