



MINISTRY OF HIGHER EDUCATION AND SCIENTIFIC RESEARCH
UNIVERSITY OUARGLA-MERBAH KASDI



Institute of Technology
Department: Applied Engineering

Project Graduation in order to obtain the diploma of
License

Field: Science and Technology
Specialty: Measure, Metrology & Quality

Realized by:
BARHOUM INAS

FIRE ALARM SYSTEM USING ARDUINO

THE JURY:

DrMECHRI Med laid	University of Ouargla	Examiner
Dr. SETTOU Belkhir	University of Ouargla	Director
Dr. ROUABEH Boubaker	University of Ouargla	President

Academic Year 2022/2023

ACKNOWLEDGMENT

First of all, I would like to praise ALLAH, the most merciful
for making

the realization of my project possible and also for making m
wishes come true and achieving my goals.

In these few lines, I would like to thank all the people who, in
one way or another, have contributed to the smooth running of
my work, both on human and scientific matters.

I would also like to show gratitude to the members of the jury
Dr. ROUABEH Boubaker and Dr. MECHRI Med laid for being
attentive to my work and for having also agreed to participate
in the examination committee.

My thanks as well go to my supervisor Mr. SETTOU Belkhir.

I express my gratitude to all the professors of the Applied
Engineering Department who has contributed to my training, I
ask them to believe in my capacities in the hope that this
humble work will give credibility to their efforts.

And a big thank you to me

.

DEDICATION

To myself,
To my dear parents,
To my brother and my sisters,
To my friends and colleagues,
To anyone who helped me during
the difficult time on this work,
And last but not least to my
soulmate,
I dedicate this humble work.

TABLE OF CONTENTS

ACKNOWLEDGMENT.....	I
DEDICATION.....	II
TABLE OF CONTENTS.....	IV
LIST OF FIGURES.....	V
LIST OF TABLES:.....	VI
GENERAL INTRODUCTION.....	VII
Chapter 01. FIRE ALARM SYSTEMM	1
1.1 INTRODUCTION:.....	1
1.2 FIRE ALARM SYSTEM(FAS):.....	1
1.3 HISTORY OF FIRE ALARM SYSTEMS:.....	2
1.4 THE FIRE PROTECTION ASSOCIATIONS:.....	3
1.5 FIRE ALARM SYSTEM COMPONENTS:	4
1.5.1 FIRE ALARM CONTROL UNIT:.....	4
1.5.1.1.1 Programmable logic controller (PLC): ...	5
1.5.1.1.2 ARDUINO:	6
1.5.2 FIRE ALAR INITIATING DEVICES:	6
1.5.3 FIRE ALARM NOTIFICATION DEVICES:	7
1.5.4 POWER SUPPLY:.....	8
1.5.4.1.1 The primary power supply:	8
1.5.4.1.2 Backup Power Supply:	8
1.6 CHARACTERISTICS OF ALARM:.....	8
1.7 TYPES OF FIRE ALARM SYSTEM:.....	10
1.7.1.1 MANUAL & AUTOMATIC:	10
1.7.1.2 WIRED& WIRELESS:	11
1.7.1.3 MONITORED AND UNMONITORED:	11
1.7.2 NEED IT TO KNOW ABOUT THE RIGHT ALARM SYSTEM:.....	12
1.7.2.1 Installation:.....	12
1.7.2.2 Total Cost of Ownership (TCO):.....	12
1.7.2.3 System Features:	13
1.7.3 MAINTAINING A FIRE ALARM SYSTEM:	14
1.7.4 FIRE ALARM SYSTEM ADVANTAGES AND DISADVANTAGES:.....	14
1.8 CONCLUSION:	15

Chapter 02.	ARDUINO BOARD	17
2.1	INTRODUCTION:.....	18
2.2	ARDUINO MICROCONTROLLER:.....	19
2.2.1	WHAT IS AN ARDUINO?	19
2.3	WHAT DOES IT DO?.....	20
1.1	WHERE TO BUY:.....	20
2.4	APPLICATIONS:	21
2.5	GOOD REASONS TO CHOOSE ARDUINO:.....	21
2.6	ELEMENTS OF ARDUINO BOARDS:.....	22
2.6.1	ARDUINO HARDWARE:	22
2.6.1.1	THE DIFFERENT VARIETIES OF ARDUINO BOARDS:	23
2.6.1.2	ARDUINO CLONES:.....	25
2.6.1.3	THE EXTENDED FAMILY:.....	26
	SENSORS:	26
	SHIELDS:.....	27
2.6.2	ARDUINO SOFTWARE (IDE)	28
2.7	THE ADVANTAGES AND THE LIMITS OF ARDUINO:	32
2.7.1	ADVANTAGES OF ARDUINO:.....	32
2.7.2	LIMITATIONS OF ARDUINO:.....	33
2.8	CONCLUSION:	34
Chapter 03.	CONTROLLING FIRE ALARM SYSTEM USING	
ARDUINO	35	
3.1	INTRODUCTION	36
3.2	THE COMPONENTS REQUIRED TO THE FIRE ALARM SYSTEM:.....	36
3.2.1	ARDUINO MEGA:.....	36
3.2.2	FLAME SENSOR:	38
3.2.2.1	APPLICATION:.....	39
3.2.2.2	FLAME SENSOR SPECIFICATIONS:.....	39
3.2.2.3	HOW TO CALIBRATE THE FLAME SENSOR:.....	39
3.2.3	MQ 2 GAS SENSOR:.....	41
3.2.3.1	APPLICATION:.....	42
3.2.3.2	MQ 2 GAS SENSOR SPECIFICATIONS:.....	42
3.2.3.3	HOW TO CALIBRATE THE MQ-2 GAS SENSOR:	43
3.2.4	OLED DISPLAY:.....	44
3.2.4.1	OLED DISPLAY SPECIFICATIONS:.....	44
3.2.5	BUZZER:	44

3.3	ARDUINO FIRE ALARM SCHEMATICS:	45
3.4	THE CODE THAT USES IT:.....	46
3.5	RESULT:	51
3.6	UNCERTAINTY OF THE SYSTEM:	52
3.7	CONCLUSION:	53
GENERAL CONCLUSION:		55
REFERENCE:		56
ABSTRACT:		III

LIST OF FIGURES

Figure 1-1: fire alarm system	2
Figure 1-2: development of fire alarm	3
Figure 1-3: THE FIRE ALARM CONTROL UNIT COMMUNICATION	5
Figure 1-4: control unit exemple: (A) ARDUINO (B) PROGRAMMABLE LOGIC CONTROLLER.	6
Figure 1-5: CHARACTERISTICS OF ALARM	9
Figure 1-6: (B) Automatic initiating devices, (A) Manual initiating devices.....	10
Figure 1-7: (A) WIRELESS FIRE ALARM SYSTEM, (B) WIRED FIRE ALARM SYSTEM.....	11
Figure 1-8: (A) unprofessional monitoring, (B) professional monitoring.....	12
Figure 2-1: the most populer types of Arduino boards.....	19
Figure 2-2: Robots using Arduino.....	20
Figure 2-3: (C) official boards can be mounted in a chassis, (A) holes, (B) Arduino designed for mounting on a breadboard.....	23
Figure 2-4: Sensor compatible with Arduino	26
Figure 2-5: some of the populer Arduino shields	27
Figure 2-6: types of Arduino shields	28
Figure 2-7: board is working.....	32
Figure 3-1: Arduino Mega.	37
Figure 3-2: FLAME SENSOR	39
Figure 3-3: MQ-2 GAS SENSOR	42
Figure 3-4: OLED DISPLAY CONNECTED WITH ARDUINO	44
Figure 3-5: Buzzer.....	45
Figure 3-6: fire alarm system using Arduino	51
Figure 3-7: sensors values.....	52

LIST OF TABLES:

Table 1-1:types of initiation devices	7
Table 12--:some types of notification devices	8
Table 3:technical specifications of Arduino Mega 2560.....	38

GENERAL INTRODUCTION

In recent years, Algeria has witnessed an alarming rise in fire incidents, posing significant risks to public safety, property, and the environment. Fires can cause devastating consequences, resulting in loss of life, destruction of infrastructure, and economic setbacks. Addressing this pressing issue requires proactive measures, innovative technologies, and comprehensive fire prevention strategies.

This work aims to introduce an Arduino-based fire alarm system as a promising solution to enhance fire safety and response in Algeria. By leveraging the power of Arduino microcontrollers, this system offers an efficient and cost-effective approach to detect and respond to fire incidents promptly, potentially minimizing their impact.

The Arduino platform provides a versatile and accessible framework for developing and deploying customized fire alarm systems. With its open-source nature and an extensive ecosystem of sensors, actuators, and communication modules, Arduino enables the integration of various detection mechanisms, real-time monitoring, and alerting mechanisms.

The proposed fire alarm system incorporates advanced sensors, such as temperature and smoke detectors and temperature sensor, to identify fire hazards in their early stages. By constantly monitoring environmental conditions, these sensors can quickly detect abnormal changes and trigger an immediate response. When a potential fire is detected, the system activates a series of predefined actions, including sounding alarms, and sending notifications to relevant authorities and individuals.

This work considers the affordability and accessibility of the proposed system. By utilizing Arduino, which is known for its cost-effectiveness and ease of use, the fire alarm system becomes a viable option for various settings, including residential buildings, commercial complexes, and public facilities. Its low-cost nature can potentially encourage widespread implementation, thus increasing the overall fire safety standards in Algeria.

Chapter 01. FIRE ALARM SYSTEMM

1.1 INTRODUCTION:

The alarm system (AS) is a messaging gadget. It collects, manages, and distributes information about abnormal conditions and shows what is happening to the user[1]. By definition, "an alarm system is the collection of hardware and software that detects an alarm state, communicates the indication of that state to the operators, and records changes in the alarm state" ,and an alarm is "an audible and/or visible means of indicating to the operator an equipment malfunction, process deviation, or abnormal condition requiring a response"[2].

Alarm systems are a type of security system designed to alert users to potential risks. They are commonly used in homes and businesses to protect against intruders, fires, and other threats. Alarm systems can be wired or wireless, triggered by motion, sound, or other sensors.

It comes in many different varieties, from basic systems to more sophisticated systems with multiple sensors and features, and it can be monitored by a professional monitoring service or can be self-monitored with the use of a smartphone app.

In this chapter, we take in more information about fire alarm systems and their history, go into more detail about the basic components, and then look at the most important characteristics that distinguish an alarm system[2].

This chapter also highlights the different types of alarm systems. not only that, but how to choose the right system, and its advantages and disadvantages.

1.2 FIRE ALARM SYSTEM(FAS):

The fire alarm system is a security system, and it is a unit made of several devices, designed for the fire protection of given objects it helps in notifying the presence of fire in their vicinity. When a fire detector detects a fire through the central electrical fire alarm system, it can perform signaling, whether audial or visual., and automatically contact the Fire and Rescue Service operation center. and can also perform object control, for example, starting sprinklers, opening fire doors, opening windows, activating safety gates, and so on. Fire alarms are usually set in fire alarm systems to provide zonal coverage for residences and commercial buildings[3].

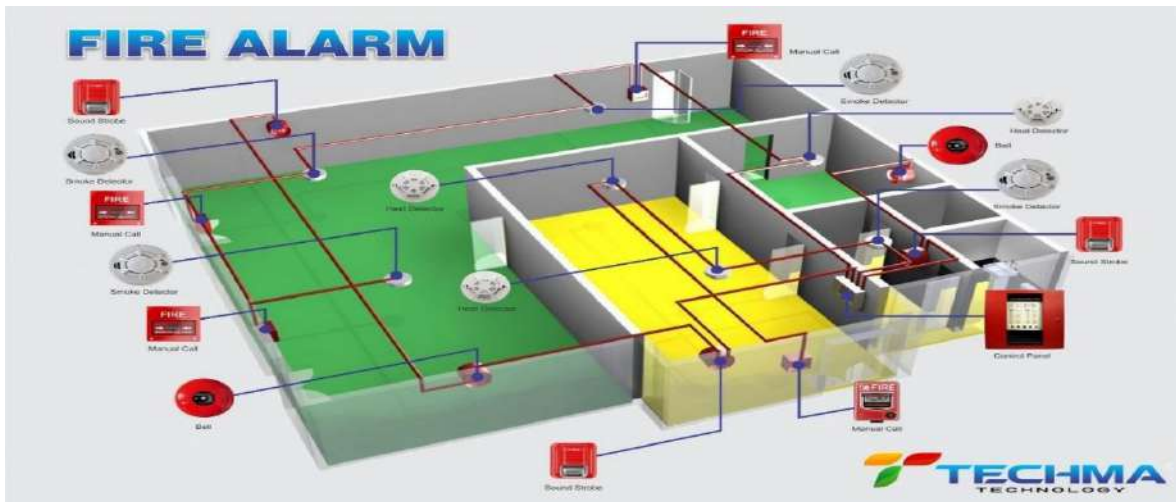

Figure 1-1: fire alarm system

1.3 HISTORY OF FIRE ALARM SYSTEMS:

Fire alarm history is long and storied, and reflecting upon past progress allows homeowners, business owners, and fire alarm security providers to better protect against fire threats. and the future of modern alarm systems has gone through many stages.

- Before humanity harnessed the power of electricity:

The first fire alarm system was invented in 1852, before humanity harnessed the power of electricity, by Dr. William F. Channing and Moses Farmer. The system includes two fire alarm boxes that have a telegraphic key and a handle each. If a fire was found in a home or business, somebody would need to reach inside one of the boxes and wrench the handle so that it could send an alert to a nearby alarm station. An operator at the station would then take the message and notify the fire department so that they could send help[4].

- After humanity harnessed the power of electricity:

The first electric fire alarm system was invented in 1890 by Francis Robbin Upton, an accomplice of Thomas Edison. He perceived that, most of the time, people wouldn't have time to remain around and wrench a handle in the case of fire. Therefore, his electric system disposed of the requirement for this progress. Surprisingly, the plan for his system was not that popular when it was first presented, but after some time, people started to understand the need for a more developed fire alarm system like this one[5].

Since then, with technology advancing, fire alarm systems have been growing. Being one of the most important systems in modern life, the field of fire alarm systems has always



Figure 1-2 development of fire alarm

been developing (as shown in Figure 12-). In the future, it may be one of the main focuses of smart home technology.

1.4 THE FIRE PROTECTION ASSOCIATIONS:

There are a lot of fire protection associations, we mention some examples:

- National Fire Protection Association (NFPA):

The National Fire Protection Association is a U.S. based international nonprofit organization devoted to eliminating death, injury, property and economic loss due to fire, electrical and related hazards[6].

NFPA publishes more than 300 consensus codes and standards intended to minimize the possibility and effects of fire and other risks. NFPA codes and standards, administered by more than 260 Technical Committees comprising approximately 10,000 volunteers, are adopted and used throughout the world.

- The Confederation of Fire Protection Associations Europe:

The Confederation of Fire Protection Associations Europe (CFPA-Europe) is an association of national bodies from around Europe working primarily in the field of prevention and protection, as well as the safety of persons and assets in the face of fire, theft, and other associated risks[7].

- The Fire Protection Association of Southern Africa (FPASA):

The Fire Protection Association of Southern Africa (FPASA) was established in 1973 to provide a specialized fire safety management technical and training service to industry, commerce and society at large.

Over the years, the Association has developed a range of membership options and technical, training and fire safety management services that are recognized for their quality, professionalism and value.

Today the role of the FPASA covers Education, Information, Advice, Consultancy and Training (Fire College)[8].

1.5 FIRE ALARM SYSTEM COMPONENTS:

The modern detection structures vary in complexity from the ones which can be simple to people who include advanced detection and signaling gadgets. Such systems are generally designed and installed by using qualified people as decided with the aid of the AHJ. The layout, installation, and approval of a fire detection and alarm machine might also require popularity trying out by regulatory businesses before new homes are occupied, or the device is positioned in provider.

The layout and set up of the fire detection and alarm gadget have to conform to applicable provisions of NFPA® 70, national electric Code®, and NFPA® seventy-two, countrywide hearth Alarm and Signaling Code, and domestically followed codes and ordinances. Other standards additionally apply to the set-up of these structures. Each of the subsequent sections highlights a fundamental element of a fire detection and alarm machine.

1.5.1 FIRE ALARM CONTROL UNIT:

The fire alarm control unit (FACU), previously called the fire alarm control panel (FACP) figure (2.a), The FACU fundamentally serves as the brain for the alarm system, it contains the electronics that supervise and monitor the integrity of the fire alarm system and its components (Figure 1-3).

The FACU receives signals from alarm-initiating devices, then processes the signals, and produces output signals that activate audio and visual alarm devices. The FACU also transmits signals to an off-site monitoring station when provided. Power and fire alarm circuits are connected directly into this panel. In addition, the remote auxiliary fire control

units and notification appliances panels are considered to be part of the fire alarm system and are connected and controlled.

Controls for the system are located in the FACU (Figure 1-3). The FACU can also perform other functions, such as:

- Providing two-way firefighter communication
- Providing remote annunciator integration
- Controlling elevators, HVAC, fire doors, dampers, locks, or other fire protection features

features

The FACU can also give public address messages and mass notification.

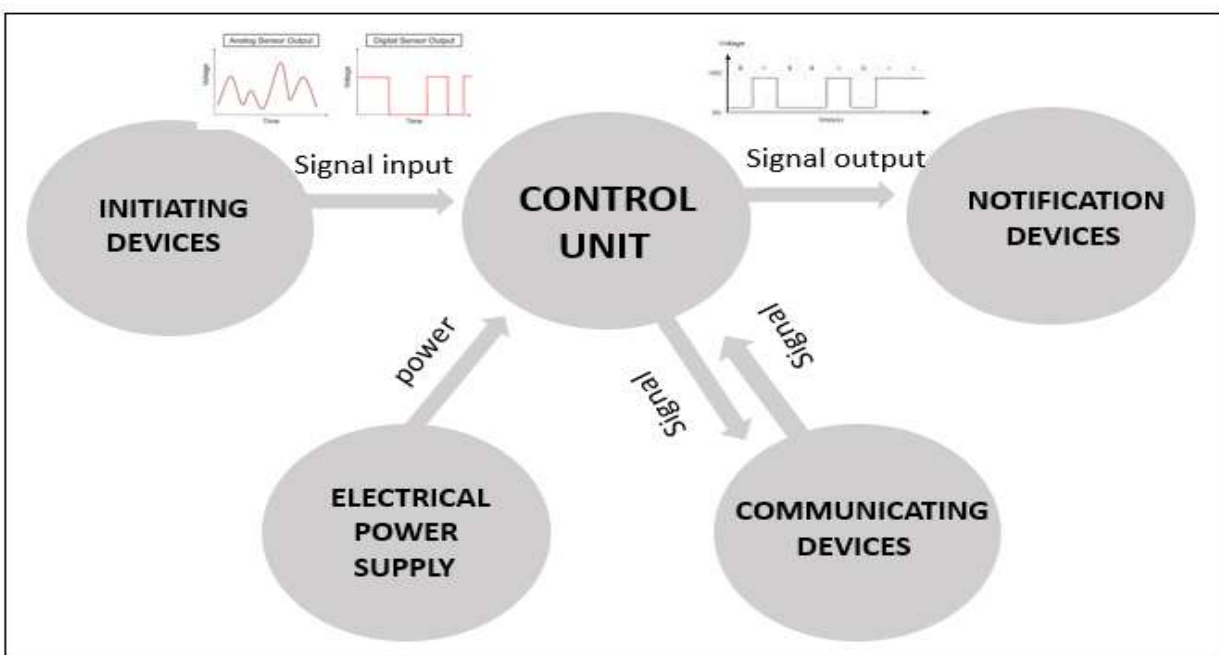

Figure 1-3: THE FIRE ALARM CONTROL UNIT COMMUNICATION

intelligent through prerecorded evacuation messages or independent voice communications.

Then there are other controllers that use it like:

1.5.1.1.1 Programmable logic controller (PLC):

programmable logic controller (PLC) is a special form of microprocessor-based controller that uses programmable memory to store instructions and to implement functions such as logic sequencing, timing, counting, and arithmetic in order to control machines and processes[9]. It uses also for control fire alarm system in industrial company (Figure 1-4).

1.5.1.1.2 ARDUINO:

It's a microcontroller used to monitor an environment with sensors, drive LED message boards, generate sound and light patterns, take and display digital photos, communicate by Bluetooth or wirelessly with other electronic devices, communicate by Wi-Fi to the Internet, and record data on the route, speed, and altitude of a trip with GPS[10].

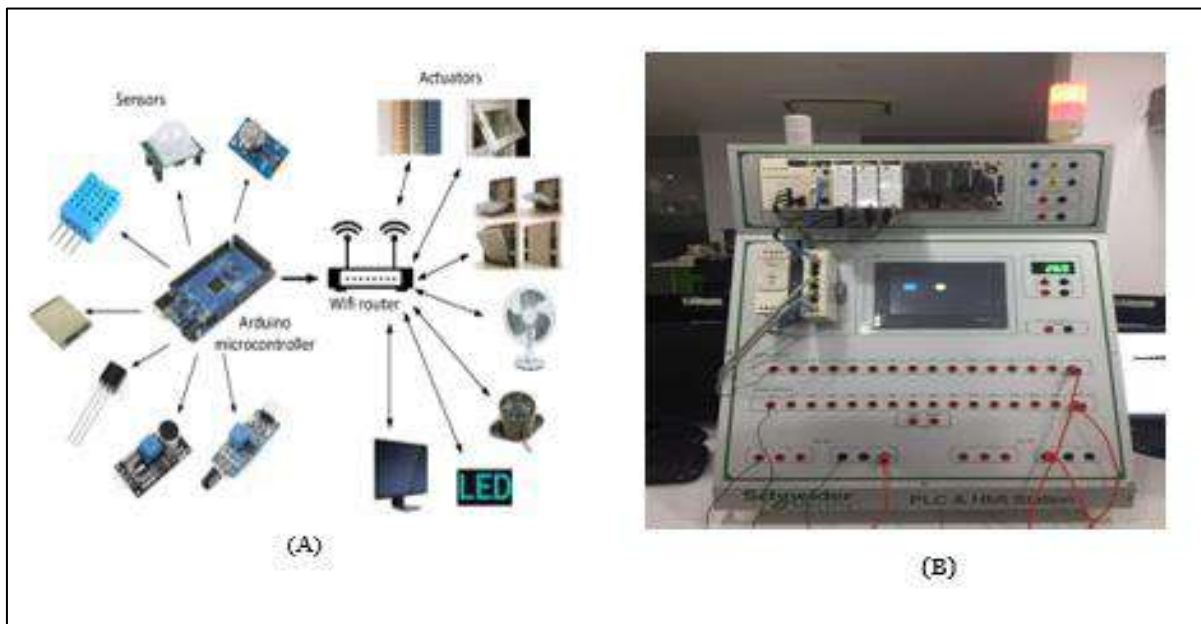



Figure 1-4:control unit exemple: (A) ARDUINO (B) PROGRAMMABLE LOGIC CONTROLLER.

1.5.2 FIRE ALAR INITIATING DEVICES:

A fire detection system consists of manual and automatic alarm-initiating devices. they are responsible for activating the system in an emergency that is activated by the presence of fire, smoke, flame, or heat, combination detectors[11].

Table 1-1:types of initiation devices

				
CO2 detectors	Air aspirating detectors	Tamper switches	Flame detectors	Heat detectors
				
Beam detectors	Smoke detectors	Duct detectors	Alarm buttons	Pull stations

In the table below, are types of initiation devices, both manual and automatic:

1.5.3 FIRE ALARM NOTIFICATION DEVICES:

Notification devices notify building occupants that a fire or emergency has been detected[11]. They can be programmed to deliver visual and audible messages relevant to different emergencies. Once an alarm-initiating device is activated, it sends a signal to the FACU, which then processes the signal and initiates actions.

Notification appliances fall under the following categories:

- Approved sounding devices "Audible", such as horns, bells, or speakers, that indicate a fire or emergency condition.
- Approved lighting devices" Visual", such as strobes or flashing lights, that indicate a fire or emergency condition.
- Visual text or symbols indicating a fire or emergency condition "Textual".

In the table below, are some types of notification devices:

Table 1-2:some types of notification devices

			
Alarm Bells	Speakers	Strobe lights	display LED & Visual text
			
Horns	Sirens	Alarm chime	Buzzer

1.5.4 POWER SUPPLY:

The majority of fire alarm systems need a primary and backup power supply.

1.5.4.1.1 The primary power supply:

The primary power supply usually comes from a 120- or 240- Volt AC power source that your property's power company supplies[11]. The FACU must supervise the primary power supply and signal an alarm if the power supply is interrupted.

1.5.4.1.2 Backup Power Supply:

As mentioned above, all fire alarm systems must have a secondary power supply just in case the primary power fails or is shut off. to ensure your fire alarm system continues to run when the primary power is out. Secondary power sources can consist of batteries with chargers, engine-driven generators with a storage battery, or multiple engine-driven generators, of which one must be set for automatic starting.

1.6 CHARACTERISTICS OF ALARM:

- Uniqueness: each alarm should indicate a unique process parameter; no duplicate alarm should be designed or defined in the control system.

- **Prioritization:** each alarm should be prioritized in such a way that the operator can clearly ascertain the criticality level of the alarm and respond accordingly.
- **Timeliness:** each alarm needs to appear on time; designing an alarm that appears too early or too late may have adverse consequences on the process operation and the operator response.
- **Understandability:** the alarm should have a suitable description that is easy to understand and use for diagnosing the triggering problem.
- **Relevance:** the alarm should be relevant to the process being monitored and should also have operational value.
- **Requiring response:** each alarm should require a definitive response from the operator.

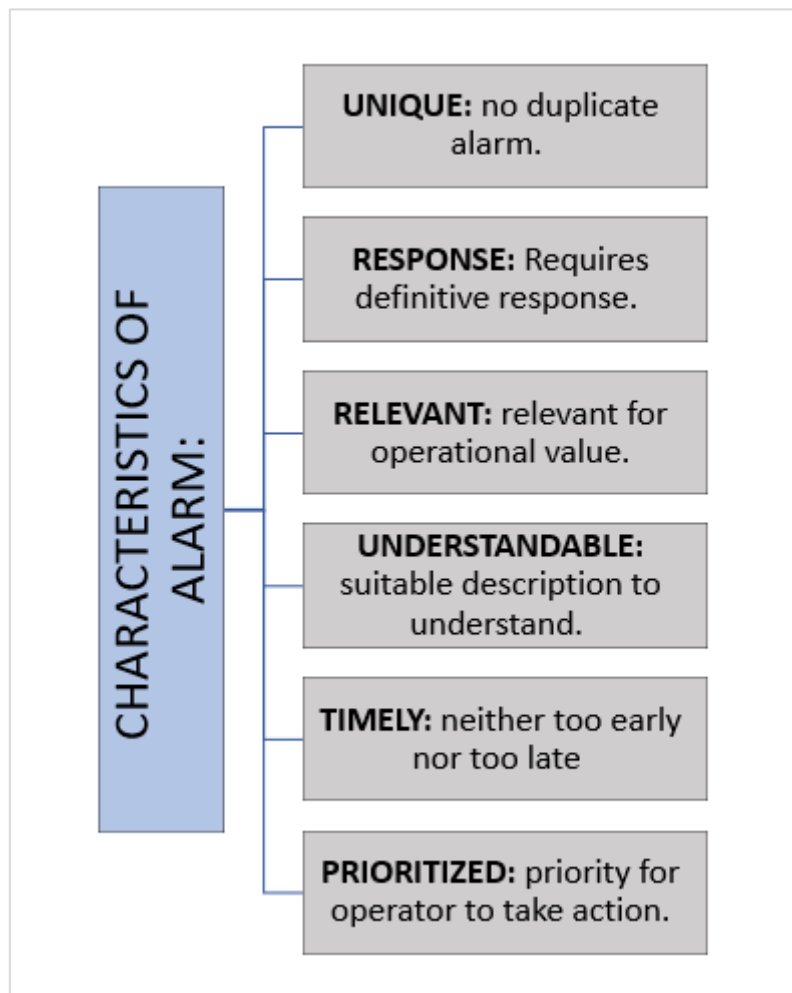

Figure 1-5:CHARACTERISTICS OF ALARM

1.7 TYPES OF FIRE ALARM SYSTEM:

Fire alarm systems keep buildings and building occupants safe from fires. Fire alarm systems are intricate networks of interconnected devices and components that work in unison to detect and alert the presence of a fire. They are divided into multiple categories based on various features. These some examples:

1.7.1.1 MANUAL & AUTOMATIC:

There are two types of fire alarm initiating devices: manual and automatic.

- Manual initiating devices are manual pull-down stations that can only be activated by hand. You are probably familiar with these devices. Most commercial buildings, including retail stores, event centers, sports arenas, and offices, have them. Manual pull-down stations are required by state and local law. NFPA 72, the fire alarm standard, even has codes pertaining to where in the building these levers must be located.
- Automatic initiating devices trigger automatically in the presence of fire. These devices include smoke detectors, fire sprinklers, and heat detectors. There are two distinct operating types among automatic devices: spot and linear.

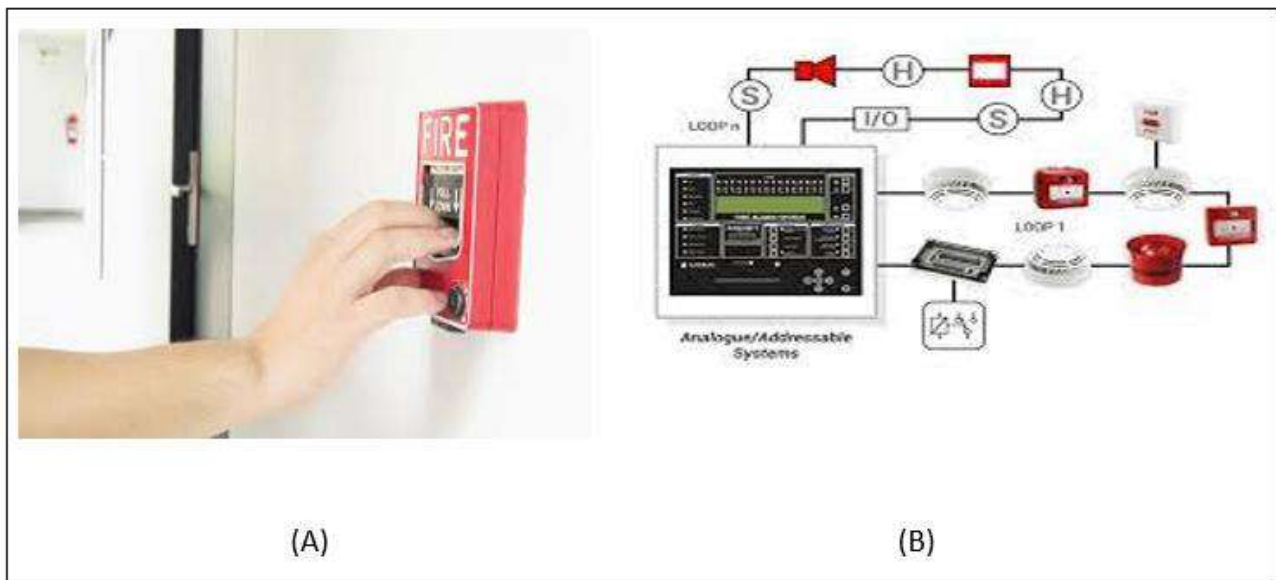

Figure 1-6:(B) Automatic initiating devices, (A)Manual initiating devices

1.7.1.2 WIRED & WIRELESS:

Wired systems are connected to the building's electrical system, while wireless systems use radio frequency signals to communicate with the control panel.

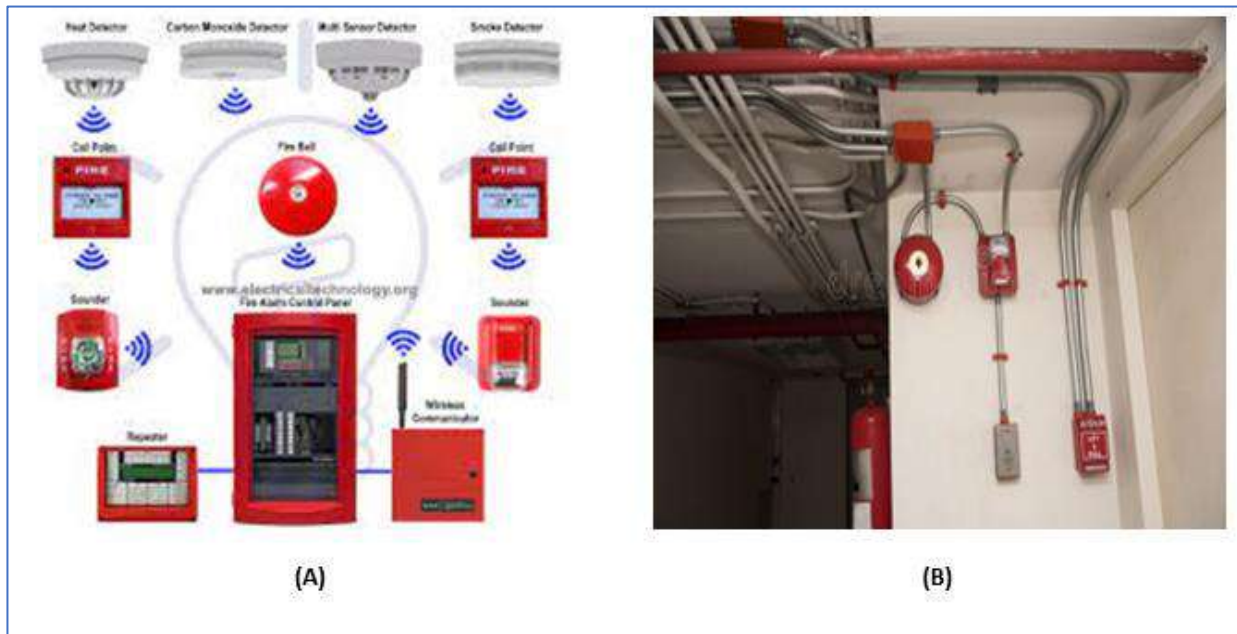

Figure 1-7:(A) WIRELESS FIRE ALARM SYSTEM, (B)WIRED FIRE ALARM SYSTEM

1.7.1.3 MONITORED AND UNMONITORED:

Monitored systems are connected to a professional monitoring service, which will contact the police or fire department in the event of an alarm. Unmonitored systems are self-monitored, and will notify the user via a smartphone app if an alarm is triggered[12].



Figure 1-8:(A)unprofessional monitoring, (B)professional monitoring.

1.7.2 NEED IT TO KNOW ABOUT THE RIGHT ALARM SYSTEM:

Choosing the right alarm system for any building (home, company, e.g.) or for any place (forest, e.g.) is difficult. There are many different types of alarms. With so many options available, it can be difficult to decide which type of system will be the best for user.

Here are five important factors that you should consider it to determine which one is best suited to your needs and budget:

1.7.2.1 Installation:

Wired systems require professional installation [8] while wireless systems can usually be installed by the user. and also, the development of cell phone or your computer, which can both provide and maintain voice support, is also available

1.7.2.2 Total Cost of Ownership (TCO):

- The cost of buying
- The installation cost of an alarm system is an important factor to consider when determining the cost of your system overall.
- the maintenance requirements: The cost of an average fire alarm system ranges from \$20 to \$30, according to Home Advisor. Some homes or condos may require

more sophisticated fire alarms, depending on what kind of hazards there are. Those cost closer to \$65 per device[8]

- **Monitoring:**

it can be monitored by a professional monitoring service or can be self-monitored with the use of a smartphone app.

Video Monitoring: Video surveillance cameras provide live surveillance of your home or business at all times. While this is an ideal feature, many homeowners do not require this type of monitoring and are more interested in being notified when something unusual happens at their property.

1.7.2.3 System Features:

A security system has a number of different features that can be configured to provide security and protection. The type of features you need will depend on your particular situation.

There are three main types of fire alarm monitoring systems: ionization, photoelectric, and combination alarms. Below we will discuss each type of alarm and how they can help detect fires.

- **Ionization**

Ionization fire alarms are best for detecting flaming fires. Inside of the alarm is a tiny bit of radioactive material (don't be alarmed – pun intended) that sits between two electronically charged plates. This causes a constant current of ionized air between the two plates. When smoke enters between the ionized current, it interrupts the current and sets the alarm off. These alarm systems are better for detecting fast, flaming fires.

- **Photoelectric**

These types of alarms are better for detecting smoldering fires. The smoke that is produced by a slow flaming, smoldering fire is much different than a raging flame fire. A photoelectric fire alarm uses a beam of light that is sent into a chamber away from a light sensor. When smoke enters the chamber, it reflects the light towards the sensor, and triggers the alarm to sound.

- **Combination**

Combination alarms feature both ionization and photoelectric fire detecting technologies. There are arguments for having combination alarms in your home, or

having both ionization, and photoelectric alarms in your home to maximize your home protection, as combination alarms aren't as great as one detection method or the other, compared to the single units.

1.7.3 MAINTAINING A FIRE ALARM SYSTEM:

Here are some procedures you'll want to adapt for maintaining your alarm system:

- Check daily to ensure the system is working correctly. Record faults and failures, and fix them.
- Test at least one detector call point weekly, as well as smoke and flame detectors. Make sure to calibrate alarm sensors.
- With systems that have numerous zones (more than 13), test more than one zone weekly.
- Check the automatic release of fire doors weekly. Also, on a weekly basis, check for disconnections of alarm sounder or transmission signals.
- Make a weekly report of defects, and alert the appropriate person to fix any problems.
- Examine batteries and connections quarterly, and replace as needed.
- Check alarm functions of indicating and control equipment quarterly. Also, test the alarm sounders quarterly, as well as links to independent monitoring companies.
- Every four months, make sure there are no obstructions around detectors.
- Ensure that a competent individual review your system on an annual basis, even if quarterly procedures have been carried out. This includes checking detectors for correct operation.
- Arrange for an annual inspection of cable fittings and equipment, confirming they're secure and protected, not damaged.
- Obtain a certificate of testing after it's determined that all of the above inspections and corrections have been made[8].

1.7.4 FIRE ALARM SYSTEM ADVANTAGES AND DISADVANTAGES:

Fire alarms are an essential safety measure that helps notify occupants of a building when there is a fire emergency. There are a number of advantages However, there are some disadvantages to fire alarm systems. We enumerate some of them in the following table:

ADVANTAGES	DISADVANTAGES
<ul style="list-style-type: none"> • providing quick response to the threat of fire disaster for residents, allowing them to evacuate from the building quickly and safely. • Can alert local authorities or emergency services. • fire alarms can be integrated with other building systems. • With an alarm system, there is a very low risk of getting hurt. • Alarm systems have several different functions, including detecting motion, smoke, heat, and other emergencies. 	<ul style="list-style-type: none"> • the false alarms can be triggered due to cooking smoke or other non-emergency situations. • the maintenance requirements and costs associated with fire alarm systems, which can add up over time. • Alarm systems can be very expensive. • Some alarm systems can produce a louder noise than others. • Some alarm systems can be slow or can't operate at all in some situations according the mark you use it.

1.8 CONCLUSION:

In conclusion, fire alarm systems are an essential component of protecting buildings and their occupants from the threat of fire. A properly designed and installed system can alert individuals early to a developing fire, giving them time to evacuate safely. These systems can also minimize property damage and limit injuries or fatalities in a building. Therefore, it is imperative that building owners proactively install and maintain these systems to ensure proper functioning in case of emergency situations. With advancements in technology, modern-day fire alarm systems have become much more efficient compared to traditional ones. However, even with advanced technology features included such as smoke detectors or automated sprinkler installations within the building facilities, it is still important for every individual on the premises always be prepared during an unexpected event such as a fire outbreak. By following safety procedures set in place alongside utilizing functional

alarms equipment available during unforeseen incidents; together employee/occupants and the identified authorities will ultimately act responsibly, if necessary, actions are required in response management modes when detecting anomalies within any type facility environments via diligent compliance with standard regulatory guidelines laid out by appropriate organizations et all.

Chapter 02. ARDUINO BOARD

2.1 INTRODUCTION:

Microcontrollers were first considered at Intel in 1969, when a Japanese company approached Intel to build some integrated circuits for calculators [13]. Their history thus spans half a century, yet their impact has been extraordinary over the past two decades. They have indeed revolutionized electronic data acquisition systems [7], which is one of their primary applications. The use of microcontrollers has revolutionized many industries, as they allow for the efficient and cost-effective development of complex systems that require sophisticated control algorithms, data processing, and communication capabilities. Additionally, microcontrollers are highly adaptable and versatile, as their programming can be customized to suit specific applications. Furthermore, microcontrollers can perform a wide range of functions, including controlling motors and sensors, managing power consumption, and communicating with other devices. Overall, microcontrollers have significantly impacted the design and functionality of modern embedded systems, making them more efficient, reliable, and adaptable to a variety of industries and applications. Moreover, microcontrollers have drastically reduced the size and increased the processing power of embedded systems. Microcontrollers have also paved the way for the development of smart systems, which can perform a wide range of complex operations based on real-time data and feedback.

A microcontroller is a compact integrated circuit consisting of a central processing unit (CPU), memory, and programmable input/output peripherals. As a self-contained system, microcontrollers are commonly used in embedded systems, which range from simple devices like washing machines and microwave ovens to complex systems such as automobiles, medical equipment, and aerospace technology [6].

The Arduino microcontroller is one of the most popular and user-friendly development boards available today, known for its simplicity, ease of use, and versatility. Arduino's boards are designed to serve both beginners and advanced users with basic programming knowledge or a computer science background.

In this chapter, we will go into greater detail about the Arduino microcontroller.

2.2 ARDUINO MICROCONTROLLER:

2.2.1 WHAT IS AN ARDUINO?

Arduino is an open-source platform used for building electronics projects. Arduino consists of both a physical programmable circuit board (often referred to as a microcontroller) and a piece of software, or IDE (Integrated Development Environment) that runs on your computer, used to write and upload computer code to the physical board[14].

The Arduino platform has become quite popular with people just starting with electronics, and for good reason. Unlike most previous programmable circuit boards, the Arduino does not need a separate piece of hardware (called a programmer) to load new code onto the board—you can simply use a USB cable. Additionally, the Arduino IDE uses a simplified version of C++, making it easier to learn to program. Additionally, Arduino provides a standard form factor that breaks out the functions of the microcontroller into a more accessible package. [9]

The Arduino is incredibly powerful, it has become a go to choice for

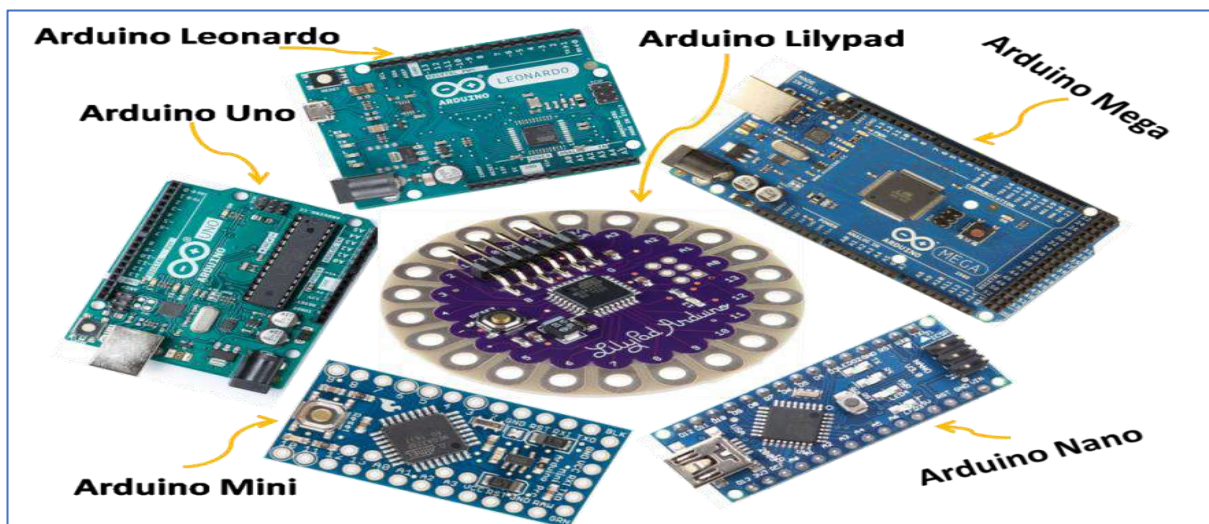

Figure 2-1: the most popular types of Arduino boards

hobbyists, tinkerers, and professionals alike. Whether you're interested in robotics, automation systems, sensors, data acquisition, or any other application that involves controlling electronics with software code. Also, the Arduino provides an accessible starting point for bringing your ideas to life.

2.3 WHAT DOES IT DO?

The Arduino hardware and software was designed for artists, designers, hobbyists, hackers, newbies, and anyone interested in creating interactive objects or environments. Arduino can interact with buttons, LEDs, motors, speakers, GPS units, cameras, the internet, and even smart-phone or TV! This flexibility combined with the fact that the Arduino software is free, the hardware boards are pretty cheap, and both the software and hardware are easy to learn has led to a large community of users who have contributed code and released instructions for a huge variety of Arduino-based projects[15].

For everything from robots and a heating pad hand warming blanket to honest fortune-telling machines, and even a Dungeons and Dragons dice-throwing gauntlet, the Arduino can

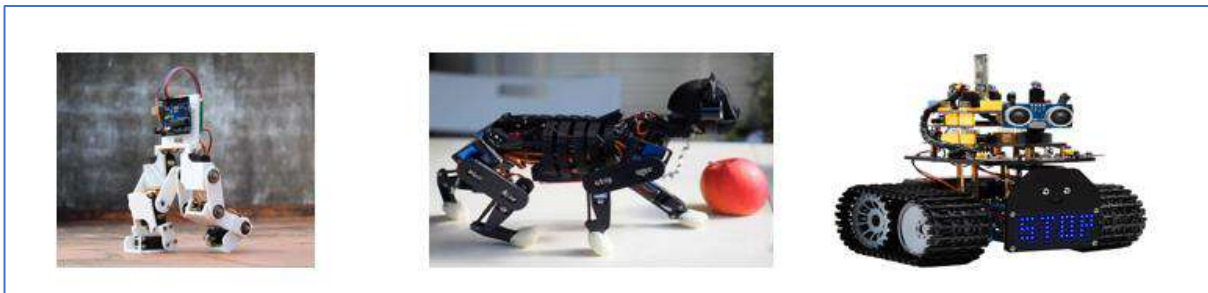

Figure 2-2 Robots using Arduino

be used as the brains behind almost any electronics project.

1.1 WHERE TO BUY:

Due to the popularity of the Arduino platform, many vendors sell Arduino and Arduino clone boards, shields, and accessories. The Arduino.cc website [16] also has a page devoted to approved distributors. If none of the resources listed here are available to you, you may want to check this page for a retailer near you[17].

Also, there are a growing number of online retailers where you can buy Arduino boards and accessories. The following lists a few of the more popular sites:

- SparkFun:

From discrete components to the company's own branded Arduino clones and shields, SparkFun has just about anything you could possibly want for the Arduino platform[8].

- Adafruit:

Carries a growing array of components, gadgets, and more. It has a growing number of products for the electronics hobbyist, including a full line of Arduino products. Adafruit also has an outstanding documentation library and wiki to support all the products it sells [18].

You can also visit the manufacturers of some of the clone boards. Seeed Studio is the leading clone manufacturer[19].

2.4 APPLICATIONS:

The Arduino system allows us to achieve many things that have applications in all areas. We have a few examples we can give:

- Control home appliances.
- Apply it to education[20].
- Use it to healthcare system[21].
- Make a play of lights.
- Communicate with the computer.
- Remote control a mobile device (model making) etc.
- Make your own robot.
- Controlling your safety system.
- With Arduino, we will make electronic systems such as an electronic candle, a simplified calculator, a synthesizer, etc. All these systems will originate with an Arduino board and a relatively wide range of electronic components as a starting point[22].

2.5 GOOD REASONS TO CHOOSE ARDUINO:

- The price: inexpensive hardware, Arduino platform is free to use from the official website and the only thing users pay is for Arduino hardware[8].
- Compatibility: The software, just like the card, is compatible with the most common platforms (Windows, Linux and Mac), unlike other tools.
- The community: The Arduino community is impressive and the number of resources about it is constantly evolving on the internet[23]. In addition, there are references to the Arduino language as well as a full page of tutorials on the arduino.cc (in English) and arduino.cc (in French) sites.

- Liberation: it's a big word, but it defines the spirit of the Arduino quite concisely. It constitutes in itself two things: The software: free and open source, developed in Java, whose ease of use depends on knowing how to click on the mouse. Equipment: electronic cards whose diagrams are in free circulation on the internet. This freedom has one condition: the name "Arduino" should only be used for "official" cards. In short, you cannot make your own board on the Arduino model and assign it the name "Arduino". Unofficial cards can be found and purchased on the Internet and are almost all compatible with official Arduino cards. Since the Arduino is open source, anyone can build and even sell Arduino compatible boards (often called an Arduino clone)[17].

2.6 ELEMENTS OF ARDUINO BOARDS:

Now, let's get closer to "using" the Arduino and see what it looks like. It consists of two main things, namely: hardware and software.

With these two tools together, we will be able to achieve any achievement.

2.6.1 ARDUINO HARDWARE:

There is a growing number of Arduino boards and each one has different specifications and capabilities. Some are configured for special applications, while others are designed with different processors and memory configurations.

The Arduino is an electronic card based on a microcontroller from the manufactures, and consists of at least one USB connection, a power connector, a reset switch, LEDs for power and serial communication, and a standard spaced set of headers for attaching the extended family like sensors & shields (boards that can be mounted adding hardware capabilities in a modular fashion)[17].

The official boards sport a distinctive blue-colored PCB with white

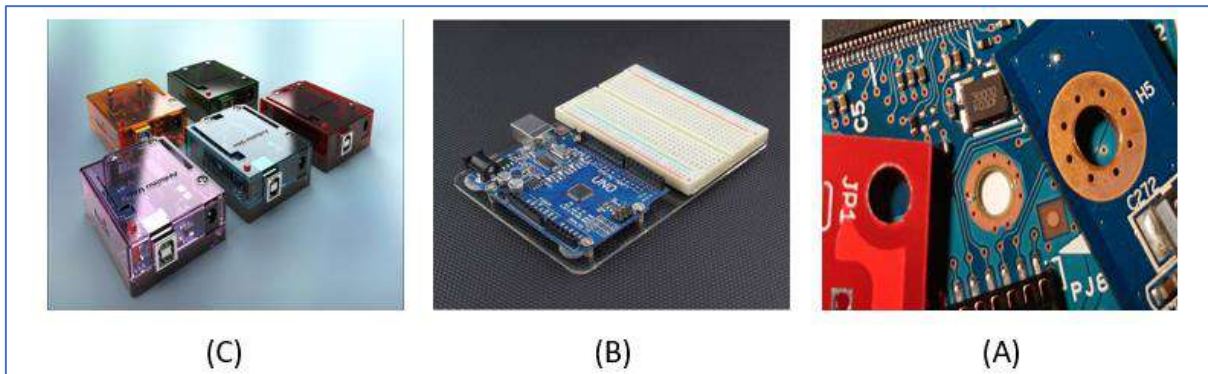

Figure 2-3:(C)official boards can be mounted in a chassis,(A) holes,(B) Arduino designed for mounting on a breadboard







lettering except one model, all the official boards can be mounted in a chassis (Figure 2-3) (they have holes in the PCB for mounting screws (Figure 2-3). The exception is an Arduino designed for mounting on a breadboard (Figure 2-3).

In this part, we show some of the most popular Arduino brand boards and the extended family.

2.6.1.1 THE DIFFERENT VARIETIES OF ARDUINO BOARDS:

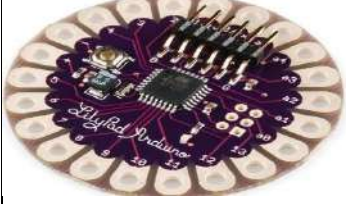
There are many Arduino microcontroller boards available on the market and each Arduino board has different specifications and capabilities. To ensure the success of your project, it's important to conduct thorough research when selecting an appropriate Arduino board. Now we mention some examples of the most popular Arduino[8]:

Types of Arduino boards	Details:	The picture of boards
THE ARDUINO UNO(R3)	Details and a full datasheet are available at[24].	





<p>MKR Series Boards</p>	<p>Details and a full datasheet are available at[25].</p>	
<p>THE ARDUINO DUE</p>	<p>Details and a full datasheet can be found at [26].</p>	
<p>LILYPAD ARDUINO</p>	<p>Details and a full datasheet can be found at[27].</p>	
<p>ARDUINO MEGA 2560- rev3</p>	<p>Details and a full datasheet can be found at[28].</p>	
<p>THE ARDUINO NANO</p>	<p>Details and a full datasheet can be found at [29].</p>	
<p>THE ARDUINO MICRO</p>	<p>Details and a full datasheet can be found at[30].</p>	
<p>ARDUINO LEONARDO</p>	<p>Details and a full datasheet can be found at[31].</p>	

2.6.1.2 ARDUINO CLONES:

A growing number of Arduino boards are available from many sources. Because the Arduino is open hardware, it is not unusual or the least bit illicit to find Arduino boards made by vendors from all over the world.

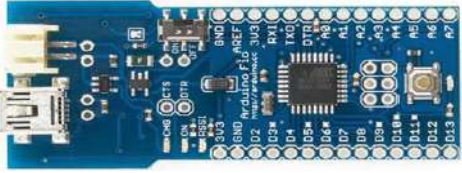
Although some would insist the only real Arduinos are those branded as such, the truth of the matter is that as long as the build quality is sound, and the components are of high quality, the choice of using a branded vs. a copy, hence clone, is one of personal preference. I have sampled Arduino boards from a number of sources, and with few exceptions they all perform their intended functions superbly[17].

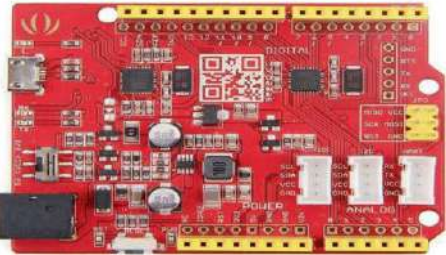
I examine a few of the more popular clone boards in this section:

Fio	Details and a full datasheet can be found at [32].	
Arduino Pro Mini	Details and a full datasheet can be found at.[32]	
Seeeduino	Details and a full datasheet can be found at [33].	
Metro from Adafruit	Details and a full datasheet can be found at [34]	

Espressif Boards :ESP8266 module (courtesy of Adafruit.com)	Details and a full datasheet can be found at [35]	
---	---	--

2.6.1.3 THE EXTENDED FAMILY:

While your Arduino board sure is pretty, it can't do a whole lot on its own -- you've got to hook it up to something. There are lots of tutorials here on learn as well as the links back in the 'What does it do' section, but rarely do we talk about the general kinds of things you can easily hook into. In this section we'll introduce basic **sensors** as well as Arduino shields, two of the handiest tools to use in bringing your projects to life.

SENSORS:

With some simple code, the Arduino can control and interact with a wide variety of sensors –things that can measure light, temperature, degree of flex, pressure, proximity, acceleration, carbon monoxide, radioactivity, humidity, barometric pressure, you name it, you can sense it



This a few of the sensors that are easily compatible with Arduino:

SHIELDS:

There are these things called shields. basically they are pre-built circuit boards that fit on top of your Arduino and provide additional capabilities -- controlling motors, connecting to the internet, providing cellular or other wireless communication, controlling an LCD screen, and much more [9].

Some of the popular Arduino Shields:

- Arduino Ethernet shield: This shield allows an Arduino board to connect to the internet by Ethernet library and to read and write an SD card using the SD library[36] Figure 2-1(A).

- Arduino Wireless shield: this shield allows the Arduino board to

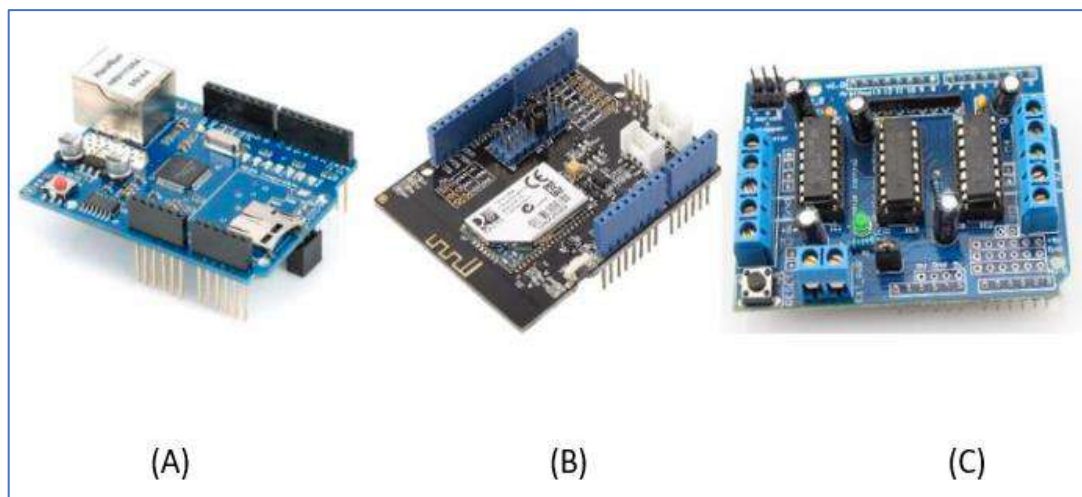

Figure 2-5: some of the popular Arduino shields

communicate wirelessly using Zigbee[36]Figure 2-1 (B).

- Arduino Motor Driver Shield: this shield allows Arduino boards to interface with the driver of a motor etc.. [36]Figure 2-1 (C).

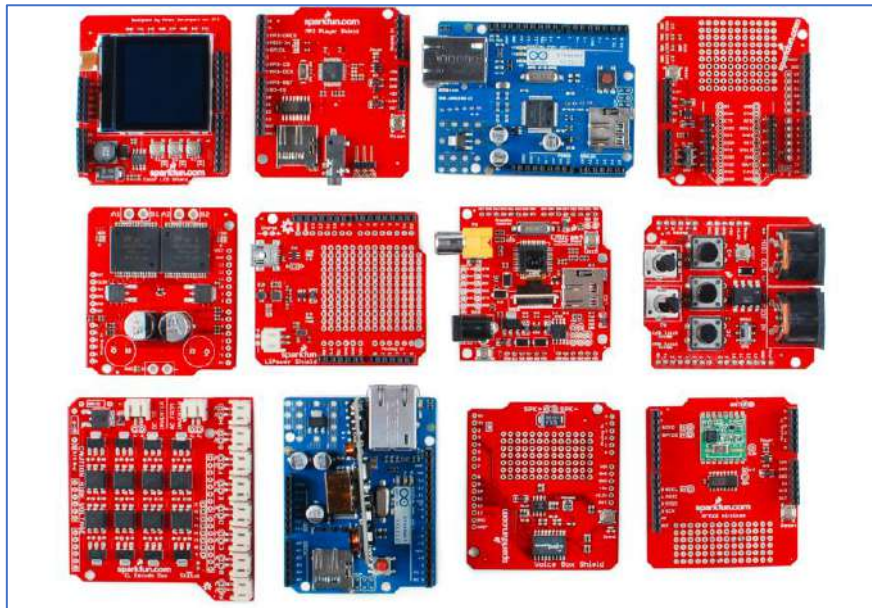

Figure 2-6: types of Arduino shields

This is a partial selection of available shields to extend the power of your Arduino. In this Figure 2-5 we show more of examples and for more details you can check this website [9] :

2.6.2 ARDUINO SOFTWARE (IDE)

The program will allow us to program the Arduino board. It offers us many features. In order to write and compile the code to the Arduino boards, Arduino Integrated Development Environment (IDE) is used. Arduino IDE is an open source and official Arduino software, which make programming code easier, even for people who have no prior knowledge. It is available in operating systems such as MAC, Windows, Linux. The IDE generally consists of two basic parts: Editor and Compiler. The former is used for writing the code and the latter is used for compiling and uploading the code into the Arduino boards, in this case, it is the Arduino Uno. The IDE supports both C and C++ language[5].

When we start the IDE, a window like figure 9 will appear. The figure marks with information about Arduino IDE for more understanding. The detailed explanations are given below:

- 1: Verify - compiles and verify the code in the sketch.
- 2: Upload - upload the code to Arduino module.
- 3: New Tab - opens a new sketch window.
- 4: Open - open any existing sketch.

- 5: Save - save current sketch.
- 6: Serial Monitor - opens a window to send and receive information from Arduino module.
- 7: An area for writing the code
- 8: Console - show details of errors and warnings, useful for debugging.
- 9: Board & Serial Port Selections - show which kind of the Arduino board and what serial port are ran. In this case, the Arduino Uno and port COM3 was used.

Furthermore, the Menu bar is on the top of the interface, which has five different options as follows:

- File: Create a new window for writing the code or open an existing one.
- Edit: Has font modification for the code, as well as copy and paste function.
- Sketch: For compiling and programming, include the new libraries for Arduino if needed.
- Tools: Used for testing projects, shows which Arduino boards and port are in used.

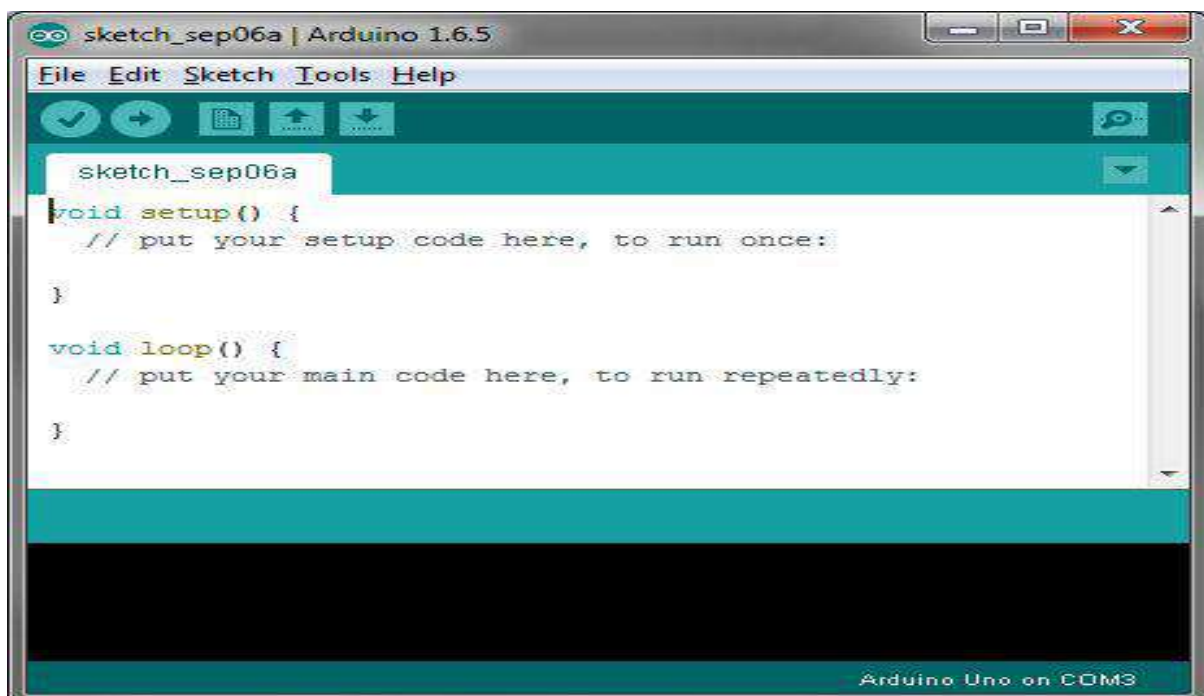

- Help: Have getting started and troubleshooting part to help with the software.

- In short take this guide summary:

1. Download and install Arduino IDE[37] .
2. Plug in your Arduino Board
3. Select the proper board in the IDE (Tools>Boards>Arduino Uno)

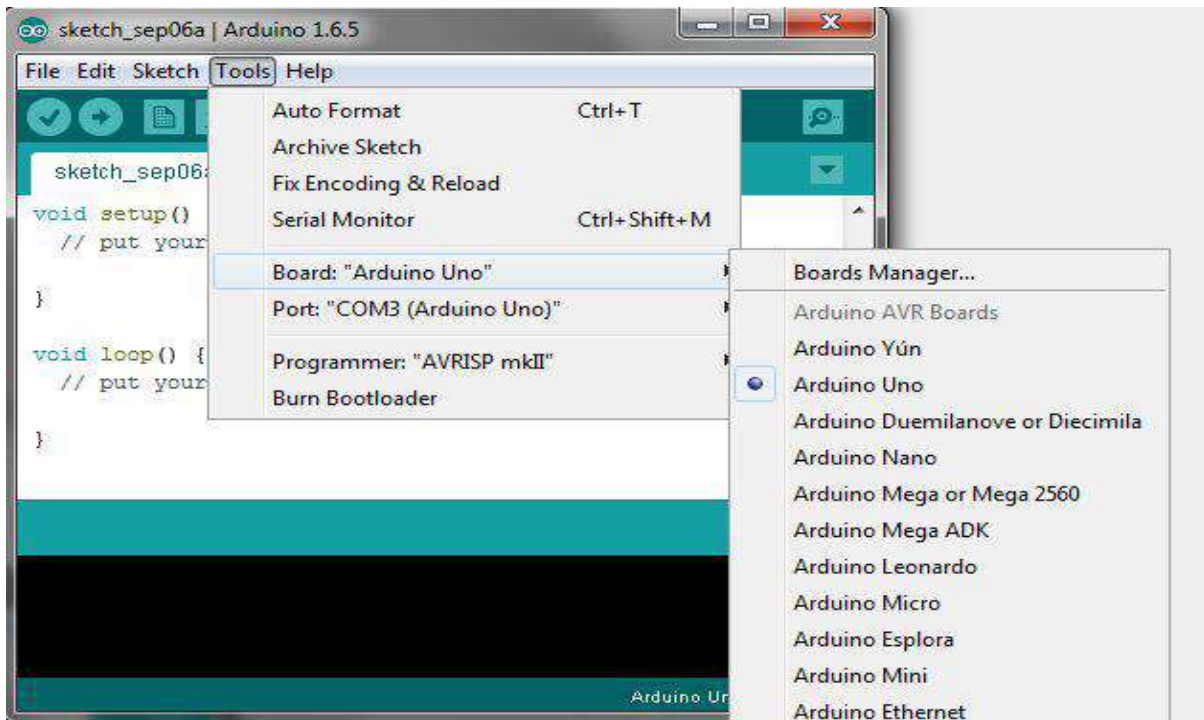

4. Select the proper COM port (Tools>Port>COMx (Arduino Uno))

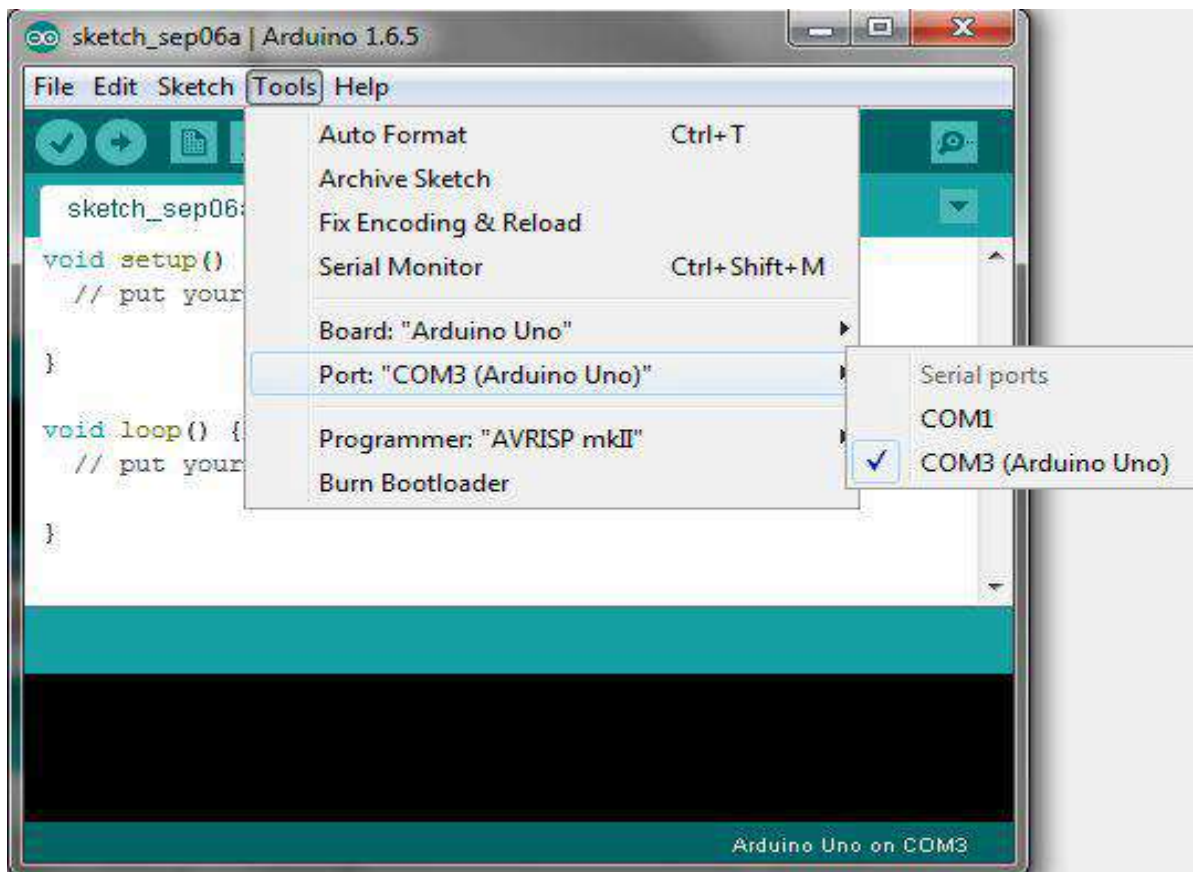

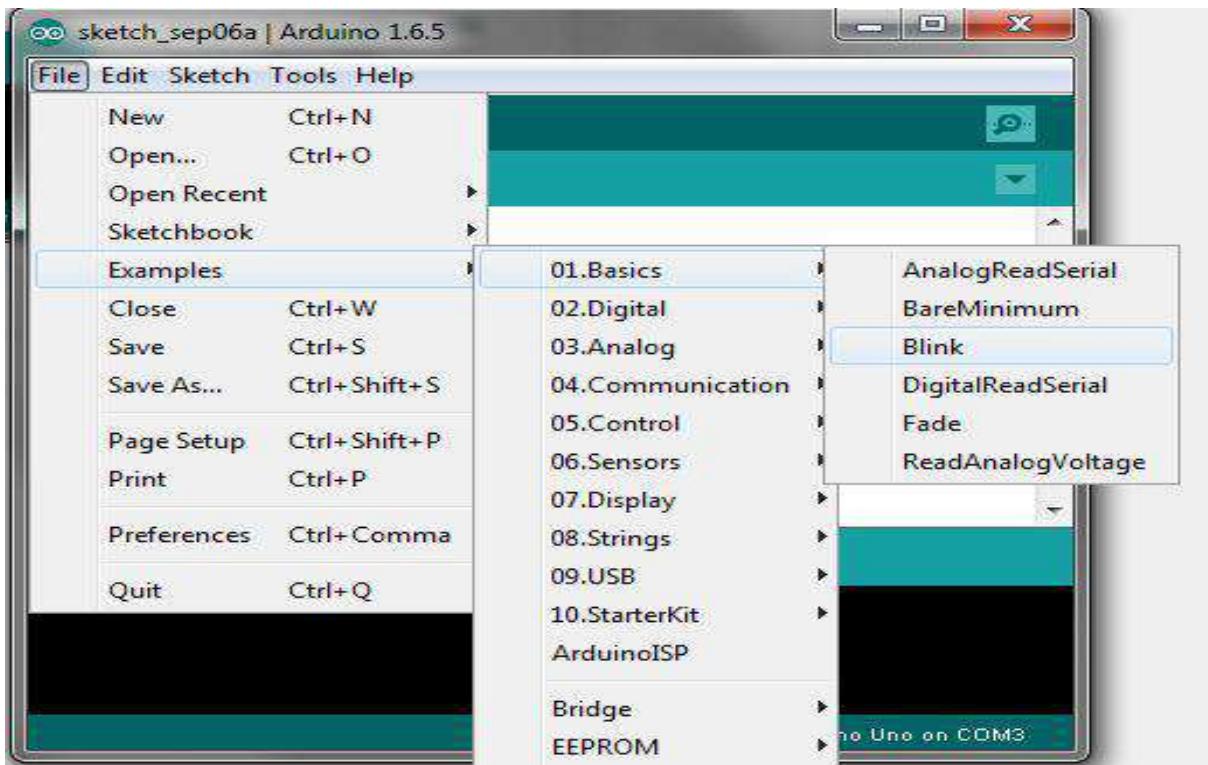

5. Open the “Blink” sketch (File>Examples>Basics>01.Blink)

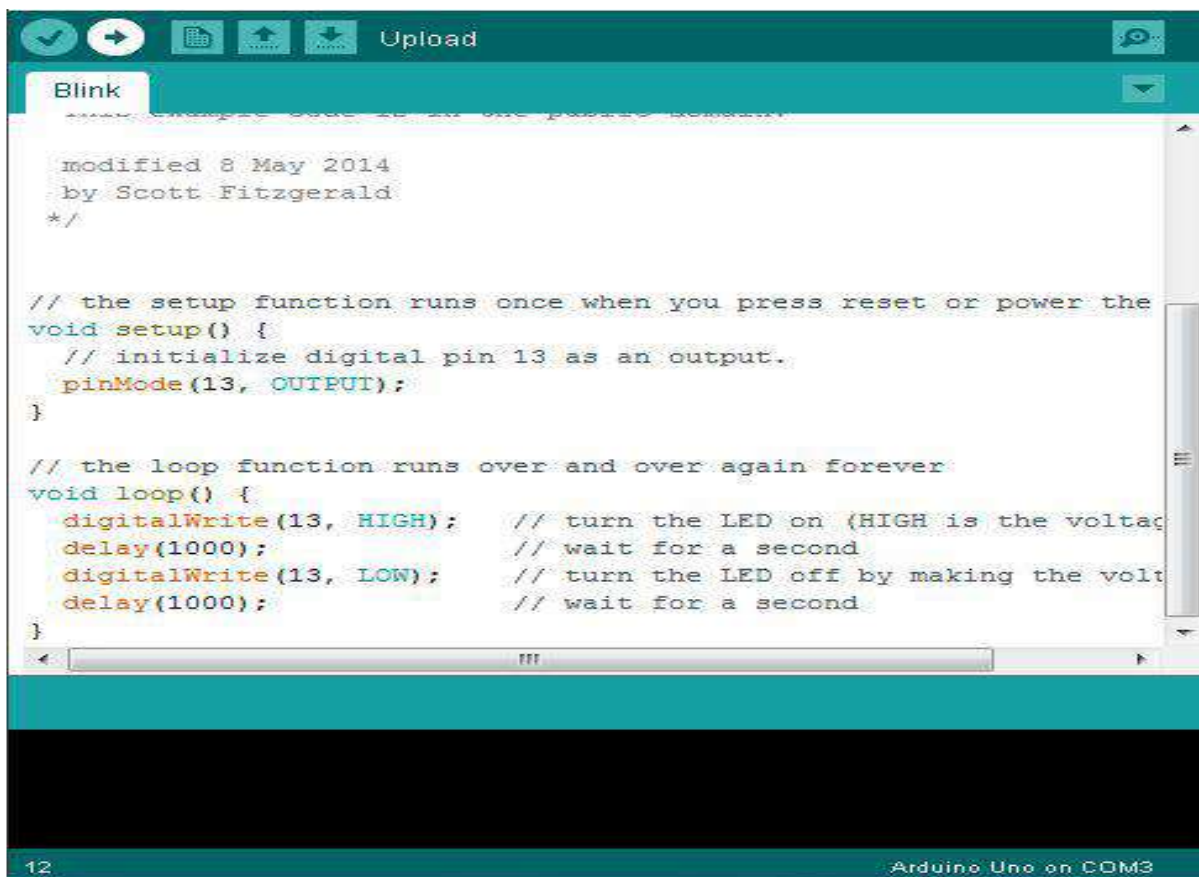

6. Press the Upload button to upload the program to the board

7. Confirm that your board is working as expected by observing LED.



Figure 2-7: board is working

2.7 THE ADVANTAGES AND THE LIMITS OF ARDUINO:

Arduino is a popular open-source electronics platform that provides a versatile and accessible way to create interactive projects. While Arduino offers numerous advantages, it also has some limitations. Let's explore both aspects:

2.7.1 ADVANTAGES OF ARDUINO:

- **Ease of Use:** Arduino boards and the associated software make it relatively easy for beginners to get started with electronics and programming. The Arduino programming language is based on a simplified version of C++, making it more approachable for newcomers.
- **Open-Source Platform:** Arduino's open-source nature encourages collaboration and community-driven development. This means that there is a vast array of resources, tutorials, libraries, and example projects available online, making it easier for users to find support and inspiration.
- **Cost-Effective:** Arduino boards are generally inexpensive compared to other microcontroller platforms. This affordability allows for experimentation and prototyping without breaking the bank. Additionally, Arduino-compatible

clones and derivatives are available, further expanding the options for budget-conscious users.

- **Versatility:** Arduino boards can be used to create a wide range of projects, from simple LED blinking to complex robotics and home automation systems. The platform supports a variety of sensors, actuators, and communication protocols, allowing users to interface with the physical world effectively.
- **Extensibility:** Arduino boards are designed with expansion in mind. They feature standardized connectors called "shields" that allow for easy attachment of additional modules, such as displays, motor drivers, or wireless communication modules. This modularity makes it simple to customize and enhance Arduino projects.
- **Cross-Platform Compatibility:** Arduino software is available for Windows, macOS, and Linux, making it accessible regardless of the user's operating system. The IDE (Integrated Development Environment) provides a user-friendly interface for writing, compiling, and uploading code to Arduino boards.

2.7.2 LIMITATIONS OF ARDUINO:

Processing Power and Memory: Arduino boards typically have limited processing power and memory compared to more advanced microcontrollers. This can be a constraint when working on computationally intensive tasks or projects that require handling large amounts of data.

- **Real-Time Constraints:** Arduino's real-time capabilities are limited. While it can handle basic timing requirements, it may struggle with highly precise timing or complex multitasking scenarios. Real-time operating systems or more specialized microcontrollers may be better suited for applications with stringent timing requirements.
- **Lack of Native Networking:** Arduino boards lack built-in networking capabilities. While they can be interfaced with Ethernet or Wi-Fi modules, the integration and implementation of network communication can be more challenging compared to microcontrollers with native networking support.

- **Limited I/O Pins:** Arduino boards have a finite number of input/output (I/O) pins, which can become a limitation for projects requiring numerous sensors, actuators, or complex interfaces. Expanding the I/O capabilities often requires the use of additional hardware or multiplexing techniques.
- **Power Consumption:** Arduino boards are not optimized for low power consumption. If your project needs to run on battery power for extended periods, you may need to consider alternative microcontrollers that provide better power management features.
- **Lack of Advanced Features:** Arduino boards are designed for simplicity and accessibility, which means they may lack advanced features found in more specialized microcontrollers. If your project requires advanced signal processing, cryptographic operations, or complex communication protocols, you may need to explore alternative platforms.

Despite these limitations, Arduino remains an excellent choice for hobbyists, educators, and prototyping applications. It provides an ideal balance between ease of use, affordability, and versatility, enabling users to bring their creative ideas to life.

2.8 CONCLUSION:

To conclude, the Arduino microcontroller has become an essential tool for hobbyists, students and professionals in electronics prototyping. It makes innovation and creativity accessible to everyone with its simple programming language and user-friendly interface. The versatility of the platform enables users to create many different types of devices, ranging from everyday appliances to complex interactive systems. Thanks to its open-source character, a community of developers constantly improve it so that it keeps up with the latest technology trends. As such, the Arduino microcontroller is a perfect choice for anyone looking into entering the world of digital design or wants an affordable option for any digital projects they want to undertake. Therefore, the availability of such innovations fuel not just creativity but also scientific research as they provide access to affordable components critical in R&D projects ultimately leading towards new solutions aimed at simplifying everyday activities.

Chapter 03. CONTROLLING FIRE ALARM SYSTEM USING ARDUINO

3.1 INTRODECTION

As technology continues to develop rapidly, there has been a growing demand for automated systems in various fields. One of the most important aspects of safety management is fire safety, and thus, designing an automatic fire alarm system has become a crucial task for engineers. Traditional fire alarms can be expensive and challenging to install, but with the advancement of technology, building a custom fire alarm using an Arduino microcontroller has become an attractive option. Arduino's microcontrollers are widely used due to their simplicity and ease of use. They can be the utilization of Arduino technology in developing an efficient and effective fire alarm system aimed at enhancing fire safety measures while minimizing potential damage caused by fires or other related accidents in residential or commercial buildings or forests.

In this chapter, we will explore the various components required to build a functional fire alarm using an Arduino board and outline the steps involved in creating it.

3.2 THE COMPONENTS REQUIRED TO THE FIRE ALARM SYSTEM:

3.2.1 ARDUINO MEGA:

The Arduino Mega is a microcontroller board based on the ATmega2560. It is one of the popular members of the Arduino family of microcontroller boards. The Mega board is designed for projects that require more input/output pins, more memory, and more processing power compared to the standard Arduino boards like the Arduino Uno.

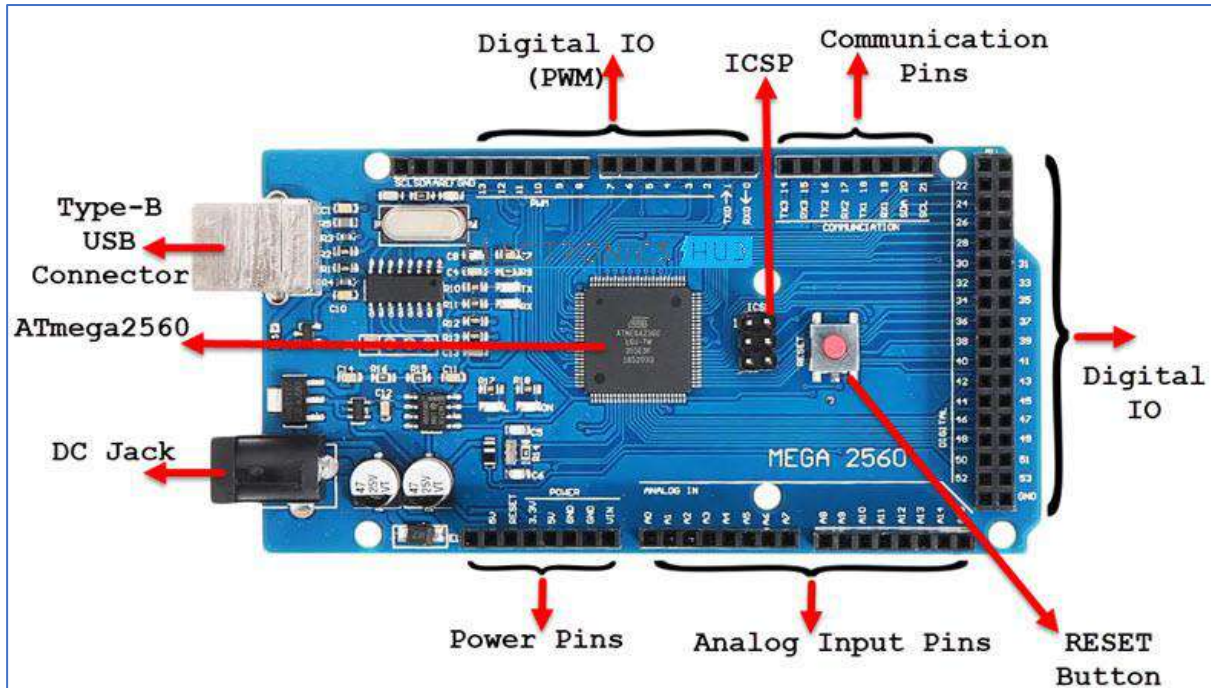

Figure 3-1: Arduino Mega.

As Arduino Mega is based on ATmega2560 Microcontroller, the technical specifications of Arduino Mega are mostly related to the ATmega2560 MCU. But none the less, let me give you a brief overview about some important technical specifications of Arduino Mega 2560.

Table 3:technical specifications of Arduino Mega 2560

Specifications	Values
Microcontroller	ATmega 2560
Operating voltage	5 V
Digital I/O pins	54 (of which 15 provide PWM output)
Analog input pins	16
Clock speed	16 MHz
Flash memory	256 kB
SRAM	8 kB
EEPROM	4 kB
Communication interfaces	UART, SPI, I ² C

3.2.2 FLAME SENSOR:

The flame sensor module is a small electronic module capable of detecting a fire source or other light sources. This sensor basically detects light wave IR (Infrared) from a light source or from a fire flame between 760 nm – 1100 nm. The flame sensor has a high-speed and sensitive YG1006 photo-transistor sensor. The detecting range is 100 cm. The Flame sensor can output either a digital or analog signal. There are two types of IR Infrared Flame Sensor Modules on the market: one with three pins (Do, Gnd, Vcc) and one with four pins (Ao, Do, Gnd, Vcc), both of them can be used with Arduino and other microcontroller boards.

This sensor has a potentiometer, a 10k preset. Adjust the sensitivity of the flame sensor by rotating the preset knob. The Flame Sensor sensitivity will increase if the preset knob rotates clockwise. The sensitivity of the Flame sensor will decrease if it rotates counter-clockwise.

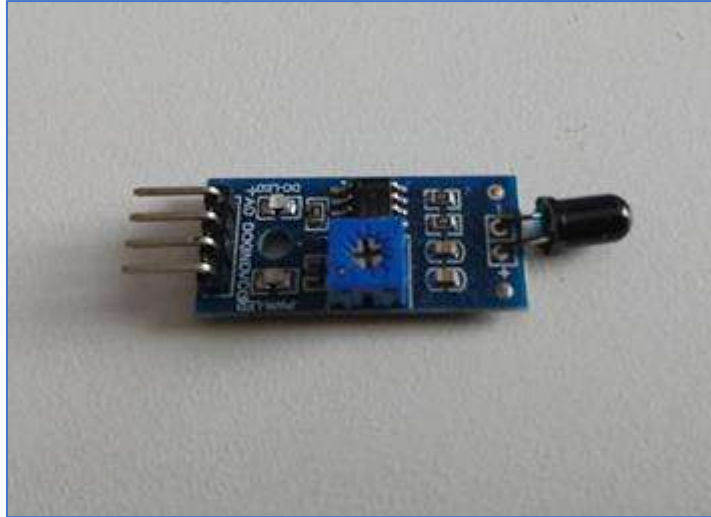

Figure 3-2: FLAME SENSOR

3.2.2.1 APPLICATION:

- Fire detection
- Use in Fire fighting robot
- Fire alarm

3.2.2.2 FLAME SENSOR SPECIFICATIONS:

- Spectrum range: 760nm ~ 1100nm
- Detection angle: 0 - 60 degree
- Power: 3.3V ~ 5.3V
- Operating temperature: -25°C ~ 85°C
- Dimension: 27.3mm * 15.4mm
- Mounting holes size: 2.0mm

For more information, you can check out the flame sensor datasheet.

3.2.2.3 HOW TO CALIBRATE THE FLAME SENSOR:

Calibrating a flame sensor typically involves adjusting its sensitivity so that it can accurately detect the presence of flames. Here's a general procedure you can follow to calibrate a flame sensor:

- ✓ Gather the necessary equipment: You'll need the flame sensor, a safe and controlled source of flames (such as a butane lighter), a multimeter (if available), and a screwdriver (if the sensor has sensitivity adjustment).
- ✓ Ensure safety: Perform the calibration in a well-ventilated area and ensure there are no flammable materials nearby. Keep a fire extinguisher or other safety equipment within reach.
- ✓ Understand the flame sensor: Familiarize yourself with the specific model of flame sensor you are using. Read the manufacturer's instructions or datasheet to understand its operating principles, sensitivity adjustment (if applicable), and recommended voltage levels.
- ✓ Connect the flame sensor: Connect the flame sensor to the appropriate power source or microcontroller, following the manufacturer's guidelines.
- ✓ Set initial sensitivity: If your flame sensor has a sensitivity adjustment, locate the sensitivity potentiometer (usually a small screw on the sensor) and set it to a mid-range position initially. This will allow you to make fine adjustments later.
- ✓ Warm-up period: Give the flame sensor some time to warm up. This is typically a few seconds to stabilize its readings.
- ✓ Activate the flame source: Use a butane lighter or another controlled source of flames to create a small, steady flame within the detection range of the sensor. Position the flame at a reasonable distance from the sensor, considering its specifications.
- ✓ Observe sensor output: Monitor the output of the flame sensor. It can be a digital signal (ON/OFF) or an analog signal (voltage level). Note the initial readings and record any changes you make during calibration.
- ✓ Adjust sensitivity: If the sensor output does not respond to the flame or if it triggers false positives, you may need to adjust the sensitivity. If your sensor has a sensitivity adjustment screw, turn it slightly in one direction (clockwise or counterclockwise) and observe the sensor's response. Gradually adjust the sensitivity until the sensor accurately detects the flame while minimizing false positives.
- ✓ Fine-tuning: Make small adjustments to the sensitivity until you achieve the desired balance between flame detection and false positives. Take note of the sensitivity setting that works best for your specific requirements.

- ✓ **Verification:** Test the sensor's response to different flame intensities, angles, and distances to ensure reliable performance in various scenarios.
- ✓ **Finalize calibration:** Once you are satisfied with the sensor's performance, secure any sensitivity adjustment screws or settings to prevent accidental changes. Make a record of the calibration parameters for future reference.

It's important to note that the specific calibration process may vary depending on the manufacturer and model of the flame sensor you are using. Always refer to the manufacturer's documentation for detailed instructions tailored to your sensor.

3.2.3 MQ 2 GAS SENSOR:

MQ-2 sensitive gas sensor material is SnO₂, which has a lower clean air conductivity. The conductivity of the sensor increases with the increase of the gas concentration when the target inflammable gas is present. Users can convert the change of conductivity by a single circuit to the corresponding gas concentration output signal. The MQ-2 gas sensor is **highly propane-smoke-sensitive** and can well detect gas and other flammable steam. It's cheap and suitable for various applications of flammable gas detection.

- Wide range good sensitivity to Combustible gases
- High sensitivity to LPG, Propane and Hydrogen
- Long life and low cost
- Simple drive circuit.



Figure 3-3:MQ-2 GAS SENSOR

3.2.3.1 APPLICATION:

- Domestic gas leakage detector
- Industrial Combustible gas detector
- Portable gas detector
- **Safety of home**
- **Control of air quality**
- **Measurement of gas level**

3.2.3.2 MQ 2 GAS SENSOR SPECIFICATIONS:

- Operating Voltage is +5V
- Can Measure or detect LPG, Alcohol, Propane, Hydrogen, CO and even methane
- Analog output voltage: 0V to 5V
- Digital Output Voltage: 0V or 5V (TTL Logic)
- Preheat duration 20 seconds
- Can be used as a Digital or analog sensor
- It can vary the Sensitivity of Digital pin using the potentiometer
- Wide detecting Scope
- Fast response and High sensitivity
- Stable and long-life Simple drive circuit

For more information, you can check out the MQ 2 Gas **sensor datasheet**.

3.2.3.3 HOW TO CALIBRATE THE MQ-2 GAS SENSOR:

To calibrate an MQ-2 gas sensor, you'll need a known concentration of the gas you want to detect. Here's a general step-by-step procedure for calibrating an MQ-2 gas sensor:

- ✓ Set up a controlled environment: Find a well-ventilated area where you can conduct the calibration without interference from other gases. Ensure that there is no potential source of gas leakage in the surroundings.
- ✓ Power the sensor: Connect the necessary power supply to the MQ-2 gas sensor. Follow the manufacturer's guidelines for the correct voltage and wiring.
- ✓ Warm-up period: Allow the sensor to warm up for about 24-48 hours. This period ensures that the sensor stabilizes and provides accurate readings.
- ✓ Prepare the calibration gas: Obtain a calibration gas with a known concentration of the target gas. It's important to use a gas mixture that matches the sensor's intended detection range.
- ✓ Connect the calibration gas: Depending on the sensor design, you may need a gas regulator or a specific connection mechanism to introduce the calibration gas to the sensor. Follow the manufacturer's instructions for proper gas flow and connection.
- ✓ Stabilization time: Give the sensor some time to stabilize after introducing the calibration gas. This allows the sensor to adjust to the new environment and ensure accurate readings.
- ✓ Record the readings: Use an appropriate measurement instrument or data acquisition system to record the sensor's output readings. This can be a microcontroller, an Arduino, or any other compatible device.
- ✓ Repeat the process: If necessary, repeat steps 4-7 with different concentrations of the calibration gas to cover the sensor's full detection range. This will allow you to create a calibration curve or map for the sensor.
- ✓ Calibration curve: Analyze the recorded data and create a calibration curve that relates the sensor's output to the known concentrations of the calibration gas. This curve will be used later to estimate gas concentrations based on sensor readings.
- ✓ Apply the calibration: Once you have the calibration curve, you can use it to convert future sensor readings into estimated gas concentrations. Implement the

calibration curve in your software or system to make use of the calibrated sensor data.

Note: The specific steps and requirements for calibrating an MQ-2 gas sensor may vary depending on the manufacturer's instructions and the sensor's design. Always refer to the sensor's datasheet and follow the provided guidelines for the most accurate calibration process.

3.2.4 OLED DISPLAY:



Figure 3-4: OLED DISPLAY CONNECTED WITH ARDUINO

3.2.4.1 OLED DISPLAY SPECIFICATIONS:

- High-resolution at 128x64 pixels
- 160 degrees viewing angle
- Lower power consumption: only 0.06W with normal use
- Power supply AC3V-5V, working very well with Arduino
- Working temperature: -30 degrees to 70 degrees Celsius
- Dimensions : L27.8 x W27.3 x H4.3 mm
- Compatible 3.3v and 5.0v chip I/O level
- Driver IC SSD1306

3.2.5 BUZZER:

For the demonstration purpose, an electromagnetic buzzer was used in this project as an alarm and warning method. To be more effective in real life



Figure 3-5: Buzzer

situation, an alarm light and a high voltage alarm can be used with relay module.

3.3 ARDUINO FIRE ALARM SCHEMATICS:

- Flame Sensor Connection:

FLAME SENSOR	ARDUINO MEGA
VCC	5V
GND	GND
A0	A0

- MQ 2 Gas Sensor Connections:

MQ-2 GAS SENSOR	ARDUINO MEGA
VCC	5V
GND	GND
A0	A1

- OLED DISPLAY CONNECTION:

OLED DISPLAY	ARDUINO MEGA
VCC	5V
GND	GND
SCL	COMMUNICATION PINS 'SCL'
SDA	COMMUNICATION PINS 'SDA'

- THE 3 NTC THERMISTOR CONNECTION:

THE 3 NTC THERMISTOR	ARDUINO MEGA
VCC	5V
GND	GND
NTC NUMBER '1'	A2
NTC NUMBER '2'	A3
NTC NUMBER '3'	A4

- BUZZER CONNECTION:

BUZZER	ARDUINO MEGA
POSITIVE	5V
NEGATIVE	PUM 10

3.4 THE CODE THAT USES IT:

The code provided is a fire alarm system that uses various sensors to detect fire. It displays the sensor values on an OLED display and triggers an alarm.

```

/*
BARHOUM INAS
SPICIAL: MESURE, METROLOGY, CONTROL OF QUALITY
FIRE ALARM SYSTEM USING ARDUINO
*/
#include <Wire.h>
#include <Adafruit_GFX.h>
#include <Adafruit_SSD1306.h>

```



```
// Pin definitions
#define FLAME_SENSOR_PIN A5
#define GAS_SENSOR_PIN A1
#define THERMISTOR_1_PIN A2
#define THERMISTOR_2_PIN A3
#define THERMISTOR_3_PIN A4
#define BUZZER_PIN 10

// OLED display settings
#define OLED_RESET 4
Adafruit_SSD1306 display(OLED_RESET);

// Thresholds for triggering the alarm
const int FLAME_THRESHOLD = 500; // Adjust this value based on your sensor
readings
const int GAS_THRESHOLD = 400; // Adjust this value based on your sensor
readings
const int TEMP_THRESHOLD = 30; // Adjust this value based on your
temperature range

void setup()
{
    Serial.begin(9600);

    // Initialize OLED display
    display.begin(SSD1306_SWITCHCAPVCC, 0x3C);
    display.clearDisplay();
    display.setTextSize(2);
    display.setTextColor(WHITE);
    display.setCursor(0, 0);
    display.println("Fire Alarm");
    display.display();

    // Initialize buzzer
    pinMode(BUZZER_PIN, OUTPUT);
}

void loop()
{
    // Read sensor values
    int flameValue = analogRead(FLAME_SENSOR_PIN);
    int gasValue = analogRead(GAS_SENSOR_PIN);

    // Convert thermistor readings to temperature in Celsius
    float temp1 = convertToTemperature(analogRead(THERMISTOR_1_PIN));
    float temp2 = convertToTemperature(analogRead(THERMISTOR_2_PIN));
    float temp3 = convertToTemperature(analogRead(THERMISTOR_3_PIN));
```

```
// Print sensor values to serial monitor
Serial.print("Flame: ");
Serial.print(flameValue);
Serial.print(" | Gas: ");
Serial.print(gasValue);
Serial.print(" | Temp1: ");
Serial.print(temp1);
Serial.print(" | Temp2: ");
Serial.print(temp2);
Serial.print(" | Temp3: ");
Serial.println(temp3);

// Check for fire condition
if (flameValue > FLAME_THRESHOLD && gasValue > GAS_THRESHOLD && temp1 >
TEMP_THRESHOLD && temp2 < TEMP_THRESHOLD && temp3 < TEMP_THRESHOLD)
{
    display.setFont();
    display.clearDisplay();
    display.setTextSize(1);
    display.setTextColor(WHITE);
    display.setCursor(0,0);
    display.println("fire detected pos1");
    display.display();
    display.drawRect(0, 0, 127, 63, WHITE);
    display.fillCircle(20, 22, 6, WHITE);
    display.drawCircle(60, 22, 6, WHITE);
    display.drawCircle(100, 22, 6, WHITE);
    display.println(" pos1: pos2: pos3: ");
    display.display();
    tone(BUZZER_PIN, 2000); // Start the buzzer
}
else if (flameValue > FLAME_THRESHOLD && gasValue > GAS_THRESHOLD && temp1 <
TEMP_THRESHOLD && temp2 > TEMP_THRESHOLD && temp3 < TEMP_THRESHOLD)
{
    display.setFont();
    display.clearDisplay();
    display.setTextSize(1);
    display.setTextColor(WHITE);
    display.setCursor(0,0);
    display.println("fire detected pos2");
    display.display();
    display.drawRect(0, 0, 127, 63, WHITE);
    display.drawCircle(20, 22, 6, WHITE);
    display.fillCircle(60, 22, 6, WHITE);
    display.drawCircle(100, 22, 6, WHITE);
    display.println(" pos1: pos2: pos3: ");
    display.display();
    tone(BUZZER_PIN, 2000); // Start the buzzer
}
```

```

}
else if (flameValue > FLAME_THRESHOLD && gasValue > GAS_THRESHOLD && temp1 <
TEMP_THRESHOLD && temp2 < TEMP_THRESHOLD && temp3 > TEMP_THRESHOLD)
{
    display.setFont();
display.clearDisplay();
display.setTextSize(1);
display.setTextColor(WHITE);
display.setCursor(0,0);
display.println("fire detected pos3");
display.display();
display.drawRect(0, 0, 127, 63, WHITE);
    display.drawCircle(20, 22, 6, WHITE);
    display.drawCircle(60, 22, 6, WHITE);
    display.fillCircle(100, 22, 6, WHITE);
display.println(" pos1: pos2: pos3: ");
    display.display();
    tone(BUZZER_PIN, 2000); // Start the buzzer
}
else if (flameValue > FLAME_THRESHOLD && gasValue > GAS_THRESHOLD && temp1 >
TEMP_THRESHOLD && temp2 > TEMP_THRESHOLD && temp3 > TEMP_THRESHOLD)
{
    display.setFont();
display.clearDisplay();
display.setTextSize(1);
display.setTextColor(WHITE);
display.setCursor(0,0);
display.println("fire detected in all");
display.display();
display.drawRect(0, 0, 127, 63, WHITE);
    display.fillCircle(20, 22, 6, WHITE);
    display.fillCircle(60, 22, 6, WHITE);
    display.fillCircle(100, 21, 6, WHITE);
display.println(" pos1: pos2: pos3: ");
    display.display();

}
else
{
    display.setFont();
display.clearDisplay();
display.setTextSize(1);
display.setTextColor(WHITE);
display.setCursor(0,0);
display.println(" no fire detected");
display.display();
display.drawRect(0, 0, 127, 63, WHITE);
    display.drawCircle(20, 22, 6, WHITE);

```

```

    display.drawCircle(60, 22, 6, WHITE);
    display.drawCircle(100, 22, 6, WHITE);
    display.println(" pos1: pos2: pos3: ");
    display.display();
    tone(BUZZER_PIN, 4000); // Start the buzzer
}

delay(1000); // Delay between sensor readings
}

// Function to convert thermistor reading to temperature in Celsius
float convertToTemperature(int reading)
{
    float resistance = 10000.0 / ((1023.0 / reading) - 1);
    float steinhart;
    steinhart = resistance / 10000;           // (R/Ro)
    steinhart = log(steinhart);              // ln(R/Ro)
    steinhart /= 3950;                       // 1/B * ln(R/Ro)
    steinhart += 1.0 / (25 + 273.15);        // + (1/To)
    steinhart = 1.0 / steinhart;             // Invert
    steinhart -= 273.15;                     // convert to Celsius
    return steinhart;
}

// Function to trigger the alarm
void triggerAlarm()
{
    tone(BUZZER_PIN, 2000); // Start the buzzer
}

// Function to stop the alarm
void stopAlarm()
{
    noTone(BUZZER_PIN); // Stop the buzzer
}

// Function to display a message on the OLED display
void displayMessage(String message)
{
    display.clearDisplay();
    display.setCursor(0, 0);
    display.println(message);
    display.display();
}

```

3.5 RESULT:

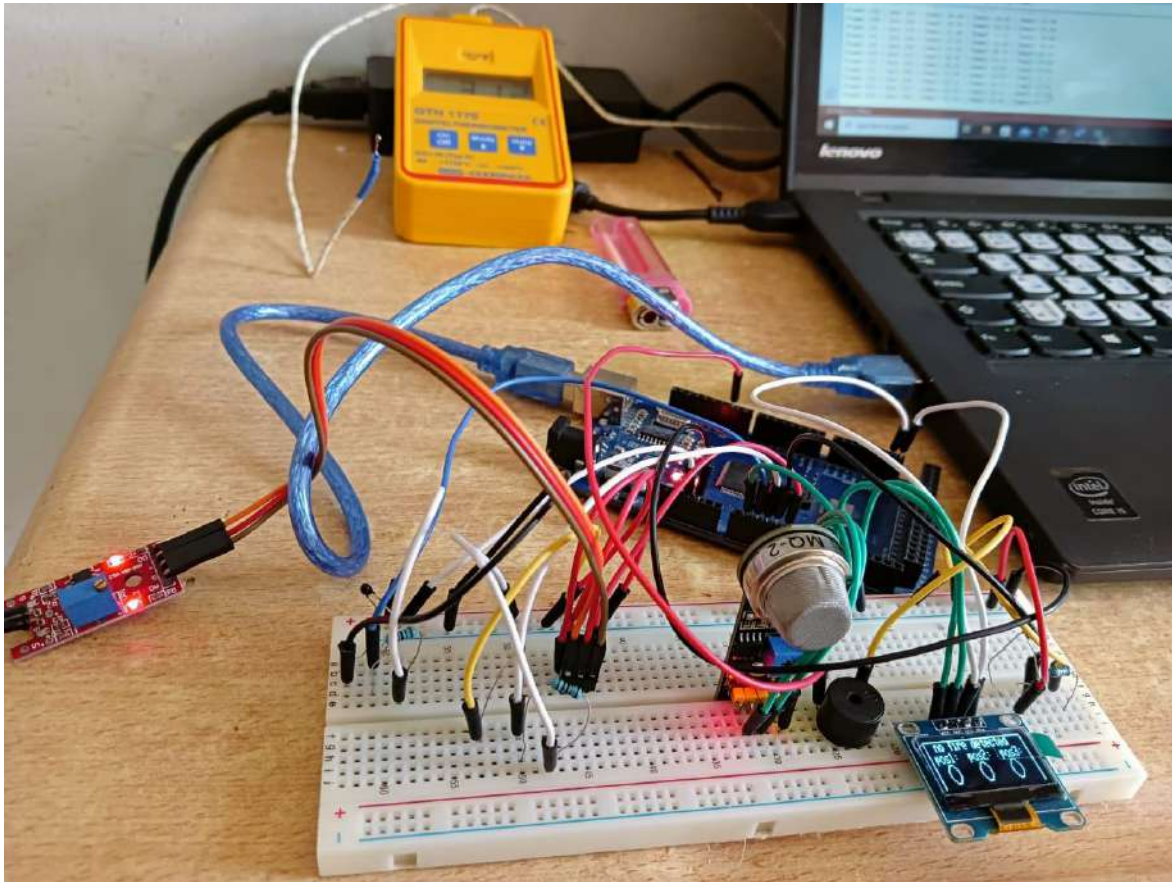

Figure 3-6: fire alarm system using Arduino

You should see the system checks for fire conditions by comparing sensor values with predefined thresholds.

If a fire is detected in a specific position, a corresponding message is displayed on the OLED display, and the buzzer starts beeping.

If no fire is detected, a message indicating no fire is displayed on the OLED display.

There is a delay of 1 second between sensor readings.

To determine the result of the code, we would need to know the actual sensor readings and the thresholds set for the flame, gas, and temperature sensors. Without

this information, we cannot determine the exact output of the code.

Output Serial Monitor ×						
Message (Enter to send message to 'Arduino Mega or Mega 2560' on 'COM6')						
Flame: 317	Gas: 212	Temp1: 27.53	Temp2: 29.25	Temp3: 28.52		
Flame: 326	Gas: 212	Temp1: 27.44	Temp2: 29.34	Temp3: 28.25		
Flame: 316	Gas: 213	Temp1: 26.99	Temp2: 29.25	Temp3: 28.98		
Flame: 317	Gas: 213	Temp1: 26.99	Temp2: 29.25	Temp3: 28.61		
Flame: 312	Gas: 216	Temp1: 27.44	Temp2: 28.89	Temp3: 28.52		
Flame: 318	Gas: 213	Temp1: 27.62	Temp2: 28.89	Temp3: 27.98		
Flame: 325	Gas: 221	Temp1: 27.62	Temp2: 28.61	Temp3: 27.98		
Flame: 320	Gas: 215	Temp1: 27.53	Temp2: 29.34	Temp3: 26.37		
Flame: 323	Gas: 215	Temp1: 27.44	Temp2: 29.34	Temp3: 26.55		
Flame: 324	Gas: 214	Temp1: 26.82	Temp2: 29.07	Temp3: 26.46		
Flame: 321	Gas: 219	Temp1: 26.99	Temp2: 29.25	Temp3: 26.82		

Figure 3-7: sensors values

3.6 UNCERTAINTY OF THE SYSTEM:

To measure the uncertainty of the system described in the code, you can consider the following aspects:

- **Sensor Accuracy:** The uncertainty of the sensor readings can contribute to the overall uncertainty of the system. Different sensors may have different accuracies, and their datasheets usually provide information about their precision and accuracy specifications.
- **Threshold Adjustments:** The code includes threshold values for the flame, gas, and temperature sensors. The uncertainty of these thresholds can affect the reliability of the system. You may need to perform calibration or validation experiments to determine appropriate threshold values and estimate their uncertainties.
- **Temperature Conversion:** The function `convert To Temperature` converts the analog readings from the thermistors to temperature values. The accuracy of this conversion process can introduce uncertainty. It depends on the accuracy of the thermistors and the correctness of the conversion equation used in the code.
- **Buzzer Operation:** The code triggers a buzzer to sound an alarm. The uncertainty of the buzzer's operation can be considered, including

factors such as the reliability of the hardware and the timing accuracy of the tone generation.

- **OLED Display:** The uncertainty of the OLED display can also be taken into account. This includes aspects like the accuracy of the displayed information and the reliability of the display itself.

To quantify the uncertainty, you can perform various types of analysis, such as:

1. **Sensor Calibration:** Calibrate the sensors against known references and determine the uncertainties associated with their readings.
2. **Threshold Sensitivity Analysis:** Evaluate the impact of small changes in the threshold values on the system's behavior and determine the resulting uncertainty.
3. **Temperature Conversion Analysis:** Assess the accuracy of the temperature conversion equation by comparing the converted values with a reference measurement device and quantify the associated uncertainty.
4. **Buzzer and Display Evaluation:** Analyze the datasheets and technical specifications of the buzzer and OLED display to understand their performance characteristics and associated uncertainties.

By considering these factors and performing the necessary analysis, you can estimate the overall uncertainty of the system and make informed decisions about its reliability and performance.

3.7 CONCLUSION:

In conclusion, the use of an Arduino-based fire alarm system is a viable and efficient solution for detecting and alerting individuals about potential fires. The Arduino microcontroller provides a cost-effective and versatile platform for designing and implementing such a system. The fire alarm system built using Arduino can effectively detect changes in temperature and smoke levels, triggering the alarm and notifying occupants to take necessary action.

One important aspect to consider when evaluating the fire alarm system is the measurement of uncertainty. It is crucial to assess the reliability and accuracy of the system to ensure it operates effectively in various scenarios. The

uncertainty can be measured by conducting rigorous testing, comparing the system's responses to known fire incidents, and analyzing false positives and false negatives. By quantifying and minimizing uncertainty, the fire alarm system's reliability can be improved, enhancing its overall performance and ensuring timely and accurate fire detection.

Looking ahead, there is potential for incorporating Raspberry Pi into the fire alarm system. Raspberry Pi is a single-board computer that offers more computational power and additional features compared to Arduino. By utilizing Raspberry Pi, the fire alarm system can be enhanced with advanced functionalities, such as real-time data analysis, remote monitoring, and integration with other smart home devices. Raspberry Pi's networking capabilities and compatibility with various sensors and modules make it a suitable candidate for expanding the fire alarm system's capabilities.

In summary, the Arduino-based fire alarm system proves to be a practical solution for fire detection, while the measurement of uncertainty helps ensure its reliability. Considering the perspective of using Raspberry Pi, it offers opportunities for further improvement and integration with modern technologies, enabling a more comprehensive and sophisticated fire alarm system.

GENERAL CONCLUSION:

In conclusion, this work aimed to address the problem of fire incidents in Algeria over the past year by proposing the implementation of a fire alarm system using Arduino. By analyzing the current scenario and considering the limitations and requirements of the Algerian context, the Arduino-based fire alarm system offers several advantages.

Firstly, the system incorporates various sensors to detect fire, smoke, and increased temperature levels, providing a comprehensive approach to fire detection. These sensors ensure a swift response to fire incidents, minimizing the risk of property damage and human casualties.

Secondly, the utilization of Arduino technology allows for cost-effective and accessible implementation. Arduino's boards are affordable and widely available, making it easier to deploy the fire alarm system across different locations in Algeria. Furthermore, the Arduino platform offers a user-friendly environment for programming and customization, enabling individuals with varying technical expertise to adapt and enhance the system to meet specific requirements.

Another significant advantage of the proposed system is its ability to provide real-time notifications and alerts. When a fire is detected, the system can immediately send alerts to designated authorities, fire departments, and building occupants, enabling them to take prompt action and evacuate the premises efficiently. This feature is particularly crucial in preventing fire incidents from escalating and improving overall response times.

REFERENCE:

1. Caproni, A. and B. Jeram, *ACS Alarm System*. 2006.
2. Goel, P., A. Datta, and M.S. Mannan, *Industrial alarm systems: Challenges and opportunities*. Journal of Loss Prevention in the Process Industries, 2017. **50**: p. 23-36.
3. Malatinsky, A. and M. Hromada, *PREVENTIVE AND REPRESSIVE MEASURES FOR FIRE SAFETY*. Annals of DAAAM & Proceedings, 2022. **33**.
4. Greer, W., *A history of alarm security*1991: National Burglar & Fire Alarm Association Bethesda, MD.
5. Luong, T., *Fire detection and alarm system*. 2019.
6. Nacereddine, B., K. Mohammed Islam, and E. Saleh, *Developing a smart embedded data collection system using microcontroller*, UNIVERSITY OF KASDI MERBAH OUARGLA.
7. Busari Sherif, A., F. Dunmoye Abibat, and F. Akingbade Kayode, *Development of Arduino-based Data Acquisition System for Environmental Monitoring using Zigbee Communication Protocol*. 2016.
8. ; Available from: www.sparkfun.com/.
9. Ahmed, A.A., *Fire alarm system using smoke and heat detectors with PLC*, 2016, Sudan University of Science and Technology.
10. Cameron, N. and Pao, *Arduino Applied*2019: Springer.
11. Ibrahim, A.N.N., *Automatic Fire Fighting System*, 2022, University of Science and Technology.
12. Salaria, A., A. Singh, and K.K. Sharma. *A Unified Approach Towards Effective Forest Fire Monitoring Systems Using Wireless Sensor Networks and Satellite Imagery*. in *Artificial Intelligence and Machine Learning in Satellite Data Processing and Services: Proceedings of the International Conference on Small Satellites, ICSS 2022*. 2023. Springer.
13. Siddig, F.H., *Designing and Implementing a Model for a Microcontroller Controlled Pick and Place*, 2014, Sudan University of Science and Technology.
14. Kondaveeti, H.K., et al., *A systematic literature review on prototyping with Arduino: Applications, challenges, advantages, and limitations*. Computer Science Review, 2021. **40**: p. 100364.
15. Arduino, S.A., *Arduino*. Arduino LLC, 2015. **372**.
16. *store.arduino.*; Available from: <https://store.arduino.cc/usa>.
17. Bell, C., *Introducing the Arduino*. Beginning IoT Projects: Breadboard-less Electronic Projects, 2021: p. 31-70.
18. *adafruit*. Available from: www.adafruit.com/.
19. *seeedstudio*. Available from: www.seeedstudio.com/.
20. García-Tudela, P.A. and J.-A. Marín-Marín, *Use of Arduino in Primary Education: A Systematic Review*. Education Sciences, 2023. **13**(2): p. 134.
21. Jayapradha, S. and P.D.R. Vincent. *An IOT based Human healthcare system using Arduino Uno board*. in *2017 International Conference on Intelligent Computing, Instrumentation and Control Technologies (ICICT)*. 2017. IEEE.
22. NETTARI, A. and A. ZIGHMI, *Etude et réalisation d'un chargeur de batterie au Lithium-ion*, Université KASDI-MERBAH Ouargla.
23. *Arduino community* Available from: <https://www.hackster.io/arduino>.
24. *data sheet*. Available from: <https://store.arduino.cc/usa/arduino-uno-rev3>.
25. *datasheet*. Available from: <https://store.arduino.cc/usa/arduino-mkr1000>.
26. *datasheet due*. Available from: <https://store.arduino.cc/usa/due>.
27. *datasheet lilypad-arduino-main-board*

Available from: <https://docs.arduino.cc/retired/boards/lilypad-arduino-main-board>.

28. *datasheet arduino-mega-2560-rev3* Available from: <https://store-usa.arduino.cc/products/arduino-mega-2560-rev3>.
29. *datasheet of arduino nano*. Available from: <https://store.arduino.cc/usa/arduino-nano>.
30. *datasheet micro*. Available from: <https://store.arduino.cc/usa/arduino-micro>.
31. *data sheet arduino leonardo*. Available from: <https://store.arduino.cc/usa/leonardo>.
32. *sparkfun products*. Available from: www.sparkfun.com/products/11520.
33. *Seeedduino*. Available from: www.seeedstudio.com/Seeedduino-V4-2-p-2517.html.
34. *Metro from Adafruit*. Available from: www.adafruit.com/category/834.
35. *Espressif Boards :ESP8266 module (courtesy of Adafruit.com)*. Available from: www.espressif.com/en/products/devkits.
36. Ismailov, A.S. and Z.B. Jo'Rayev, *Study of arduino microcontroller board*. Science and Education, 2022. **3**(3): p. 172-179.
37. *ARDUINO IDE*. Available from: <https://www.arduino.cc/en/Main/Software>

ABSTRACT:

This work presents the design and implementation of a fire alarm system using Arduino microcontroller board, along with flame sensor, MQ-2 gas sensor, NTC thermistor sensor, buzzer, and OLED display. The objective is to develop a cost-effective and efficient solution for detecting fire hazards and alerting individuals in residential, commercial, or industrial settings.

The flame sensor detects the presence of fire by sensing infrared light emitted from flames, enabling rapid fire detection. The MQ-2 gas sensor is employed to detect hazardous gases, such as smoke, LPG, and carbon monoxide, which are common byproducts of fires. The NTC thermistor sensor measures the ambient temperature to further aid in fire detection.

The Arduino board serves as the central processing unit, collecting data from the sensors and analyzing it in real-time. When a fire hazard is detected, the system triggers the buzzer to generate an audible alarm, alerting nearby individuals to evacuate the premises. Additionally, an OLED display provides visual feedback by showing relevant information, such as sensor readings and system status.

ملخص:

يقدم هذا العمل تصميم وتنفيذ نظام إنذار الحريق باستخدام لوحة متحكم Arduino ، جنبًا إلى جنب مع مستشعر اللهب ، ومستشعر الغاز MQ-2 ، ومستشعر الترمستور NTC ، والجرس ، وشاشة OLED. الهدف هو تطوير حل فعال من حيث التكلفة وفعال للكشف عن مخاطر الحريق وتنبيه الأفراد في البيئات السكنية أو التجارية أو الصناعية. يكتشف مستشعر اللهب وجود حريق عن طريق استشعار ضوء الأشعة تحت الحمراء المنبعث من اللهب ، مما يتيح الكشف السريع عن الحرائق. يتم استخدام مستشعر الغاز MQ-2 للكشف عن الغازات الخطرة ، مثل الدخان وغاز البترول المسال وأول أكسيد الكربون ، وهي منتجات ثانوية شائعة للحرائق. يقيس مستشعر الترمستور NTC درجة الحرارة المحيطة للمساعدة في اكتشاف الحرائق.

تعمل لوحة Arduino كوحدة معالجة مركزية ، حيث تقوم بجمع البيانات من المستشعرات وتحليلها في الوقت الفعلي. عندما يتم الكشف عن خطر الحريق ، يقوم النظام بتشغيل الجرس لتوليد إنذار مسموع ، لتنبيه الأفراد القريبين لإخلاء المبنى. بالإضافة إلى ذلك ، توفر شاشة OLED ملاحظات مرئية من خلال إظهار المعلومات ذات الصلة ، مثل قراءات أجهزة الاستشعار وحالة النظام

