

*People's Democratic Republic of Algeria*  
*Ministry of Higher Education and Scientific Research*  
UNIVERSITY OF KASDI MERBAH OUARGLA  
FACULTY OF MATHEMATICS AND MATHEMATICS SCIENCES  
DEPARTMENT OF PHYSICS



*Academic year 2017-2018*

## **MEMORY**

*Present in view of obtaining a Master's degree in theoretical physics*

*Thème*

# ***ON THE QUANTIC GRAVITY***

*Presented by:*

*Abdellah Othmane Fatima Zohra and Hemiss iHoussam Eddine*

*Under the direction of Dr. Khodja Lamine*

*Brief presented on the 10/06/2018, in front of the jury composed of:*

*E. Belghitar      M.A.A    Univ. KasdiMerbah — Ouargla    Président*

*M. Benbitour    M.C.A    Univ. KasdiMerbah — Ouargla    Examiner*

*L. Khodja        M.C.A    Univ. KasdiMerbah — Ouargla    Protractor*

## Dedication

*Me Mrs. Abdellah -otsmane fatima-zahra*

*I dedicate this work:*

*In memory of my father,*

*To my mother,*

*To my two very dear and precious girls Katia and*

*Soror,*

## **Thanks**

This work has been developed in the Department of Physics of the Faculty of Science of Matter and Mathematics at KasdiMarbah University - Ouargla.

I express my deep gratitude to my Master's thesis supervisor, MrKhoudjaLamine PhD student in theoretical physics, who has offered me this subject and for his constant support, for his efficient help and for his patience, his encouragement and his kindness.

I also thank MrBelghifar El hadje jury president and MrBenbitour Mohamed the examiner for their understanding.

I warmly thank my dear daughters Katia and Soror who helped me and spent together painful moments in order to finish this work in very harsh conditions.

I would also like to thank Miss DaghmoucheMessaouda, head of the chemistry department, who encouraged me to live this experience and reach the goal. Not to mention Mrs. Ben Abdesslamenaffissa teacher of organic chemistry who often supported me to complete this work.

# Contents:

Ch. 1 : Introduction.....	1
Ch. 2 : General Relativity.....	5
Ch.3 : Cosmology.....	33
Ch.4 : Loop Quantum Gravity.....	41
Ch. 5 : String Theory.....	57
Ch. 6 : D-Branes.....	81
Appendix A.....	91
Appendix B .....	92
List of references.....	95

# Chapter 01

## Introduction

**<<Science is not everything, but science is very beautiful >>[1]**

*J. Robert Oppenheimer*

<< All science is either physics or stamp collecting >>[2]. That how the biggest physicist Ernest Rutherford define physics .It is the natural science that studies matter and its

motion and behavior through space and time and that studies the related entities of energy and force[3] . Physics is one of the most fundamental scientific disciplines, and its main goal is to understand how the universe behaves[4] .

Physics became a separate science when physicists used experimental and quantitative methods to discover what are now considered to be the laws of physics . Major developments include the replacement of the geocentric model of the solar system with the heliocentric Copernican model[5], the laws governing the motion of planetary bodies determined by Johannes Kepler between 1609 and 1619[6], pioneering work on telescopes and observational astronomy by Galileo Galilee in the 16th and 17th Centuries[7], and Isaac Newton's discovery and unification of the laws of motion and universal gravitation that would come to bear his name[8] . Newton also developed calculus, the mathematical study of change, which provided new mathematical methods for solving physical problems[9] .The discovery of new laws in thermodynamics and electromagnetics resulted from greater research efforts during the Industrial Revolution as energy needs increased [10].

At the end of the 19<sup>th</sup> century, physicists believed that nothing remained unexplained, Even Lord Kelvin said : <<There is nothing new to be discovered in physics now , All that remains is more and more precise measurement >>[11].However, inaccuracies in classical mechanics for very small objects and very high velocities led to the development of modern physics in the 20th century. they appeared a two new theories : quantum mechanics and the theory of relativity , which led us to re-thinking for everything that we know.

Quantum mechanics and general relativity have extended our understanding of the physical world widely . A large part of the physics of the last century has been a triumphant march of exploration of new worlds opened by these tow theories [12].The quantum theory yielded correct predictions of a great deal of the data on the behavior of the molecular, atomic, nuclear and elementary particle domains of matter. In its form of general relativity, it

has yielded a formalism that successfully predicted features of the phenomenon of gravity, also predicted by the classical Newtonian theory .

The problem we are now faced with is that in their precise mathematical forms and their conceptual bases, the theory of relativity and the quantum theory are both logically and mathematically incompatible[13]. They each entail opposing paradigms on the true nature of matter and radiation, as well as opposing epistemologies. For the purpose of description of particular phenomena, and so long as the physical conditions that require the use of the quantum theory and the theory of relativity do not overlap, these theories may be expressed separately. But in general, for the purpose of explanation, we must consider the conditions where both theories would be required simultaneously to correctly represent the laws of nature .

In our current understanding, there exist four fundamental interactions in nature: electromagnetism, weak interactions, strong interactions, and gravity. Everyone is familiar with electromagnetism. Weak interactions are involved in the decay of nuclei. Strong interactions keep nuclei together. The rules of quantum mechanics have been applied to electromagnetism, the weak and strong interactions. It is sort of natural to apply the rules of quantum mechanics to such interactions since they play key roles in the dynamics of atoms and nuclei and one knows that at such scales classical mechanics does not give correct predictions. The rules of quantum mechanics have not been applied to gravity in a satisfactory manner up to now. Quantum gravity is an attempt to do so, but it is an incomplete theory.

Quantum gravity is the field of theoretical physics attempting to unify the theory of quantum mechanics, which describes three of the fundamental forces of nature, with general relativity, the theory of the fourth fundamental force: gravity . The ultimate goal is a unified framework for all fundamental forces-a theory of everything [14]. The unification of quantum theory with Einstein's theory of general relativity is perhaps the biggest open problem of theoretical physics. Such a theory is not only needed for conceptual reasons, but also for the understanding of fundamental issues such as the origin of the Universe, the final evaporation of black holes, and the structure of space and time .

In the last few decades, researchers have pursued the problem in two separate programs : String theory and Loop Quantum Gravity .

String theory is a theory that attempts to unify gravity with the other forces by postulating that all particles and forces arise from the vibrations of extended objects . String theory comes from the observation that all the quanta that carry the known forces, and all the known particles, can be found among the vibrations of these extended objects [15] . The main problem of string theory is that it seems to predict the wrong spacetime dimension: 26 for bosonic strings , 10 for supersymmetric strings, and 11 in the case of M theory. In order to be compatible with the observed  $3 + 1$  dimensions at the currently accessible energies, one needs to compactify some of the extra dimensions. In this process, a large amount of arbitrariness is introduced and it has remained an open problem to extract predictions from string theory which are independent of the details of the compactification. Also, our knowledge about full non-perturbative string theory is limited, with the main exceptions of D-branes and using AdS/CFT as a definition of string theory[16].

Loop Quantum Gravity is a background independent and mathematically rigorous canonical quantization of the gravitational field[17] . The main problem of loop quantum gravity is to obtain general relativity in a suitably defined classical limit. In other words, the fundamental quantum geometry present in loop quantum gravity has to be coarse grained in order to yield a smooth classical spacetime, while the behaviour of matter fields coupled to the theory should be dictated by standard quantum field theory on curved spacetimes in this limit . Also, it has not been possible so far to fully constrain the regularization ambiguities that one encounters in quantizing the Hamiltonian constraint. In order to cope with these issues, a path integral approach, known as spin foams , has been developed, as well as the group field theory approach , which is well suited for dealing with the question of renormalization[18].

Our research will focus on six chapters, the first chapter is a general introduction to our subject , the second chapter will present a reminder on the theory of general relativity, the third chapter will present some famous definitions in cosmology , the fourth chapter will introduce the String theory , the fifth chapter will introduce the Loop Quantum Gravity theory. The last chapter is a general conclusion of our research work .

**Albert Einstein**(14 March 1879 – 18 April 1955) was a German physicist who developed the theory of relativity . He received the 1921 Nobel Prize in Physics for his discovery of the law of the photoelectric effect .

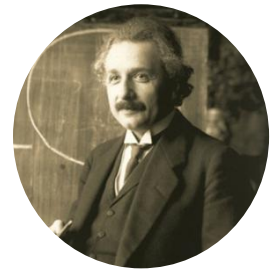

figure 1.1 Albert Einstein



**John Archibald Wheeler** (9 July 1911 – 13 April 2008) was an American physicist . He was largely responsible for reviving interest in general relativity in the United States after World War 2 . He originated a novel approach to the unified field theory and popularized the term black hole.

figure 1.2 John Wheeler

**Abhay Vasant Ashtekar**(5 July 1949 – ) is an Indian physicist . He is the creator of Ashtekar variables and one of the founders of loop quantum gravity and its subfield loop quantum cosmology .



figure 1.3 Abhay Ashtekar

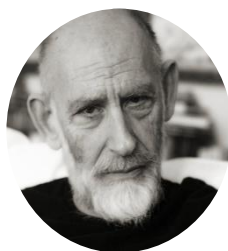

**Leonard Susskind**(20 may 1940 – ) is an American physicist who is considered to be one of the three fathers of string theory . His research interests include string theory, quantum field theory, quantum statistical mechanics and quantum cosmology.

figure 1.4 Leonard Susskind

**Carlo Rovelli**(3 May 1956) is an Italian physicist, philosopher and writer . His work is mainly in the field of quantum gravity, where he is among the founders of the loop quantum gravity theory .



figure 1.5 Carlo Rovelli



# Chapter 02

## General Relativity

*<< which was probably the greatest scientific discovery that was ever made >>*[1]

*P. A. M. Dirac*

### 2.1 Introduction

<< I believe that the general acceptance of general relativity was due in large part to the attractions of the theory itself—in short, to its beauty [2]>> , that how the famous physicist Steven Weinberg described it . So what is general relativity ?

General relativity is the geometric theory of gravitation, that was developed by Albert Einstein between 1907 and 1915 , with contributions by many others after 1915 [3] . General relativity has been described as the most beautiful of all existing physical theories[4] .

General relativity generalizes special relativity and Newton's law of universal gravitation, providing a unified description of gravity as a geometric property of space and time , or spacetime[5] .According to general relativity , the observed gravitational attraction between masses results from the warping of space and time by those masses . In particular, the curvature of spacetime is directly related to the energy and momentum of whatever matter and radiation are present [6] .

Before the advent of general relativity, Newton's law of universal gravitation had been accepted for more than two hundred years as a valid description of the gravitational force between masses, even though Newton himself did not regard the theory as the final word on the nature of gravity. Although even Newton was bothered by the unknown nature of that force, the basic framework was extremely successful at describing motion[7] .

Some predictions of general relativity differ significantly from those of classical physics , especially concerning the passage of time , the geometry of space , the motion of bodies in free fall, and the propagation of light . Examples of such differences include gravitational time dilation , gravitational lensing , the gravitational redshift of light , and the gravitational time delay[8] .

Although general relativity is not the only relativistic theory of gravity, it is the simplest theory that is consistent with experimental data. The predictions of general relativity have been confirmed in all observations and experiments to date. For example , it implies the existence of black holes – regions of space in which space and time are distorted in such a way that nothing , not even light , can escape– as an end-state for massive stars.

General relativity also predicts the existence of gravitational waves , which have since been observed directly by the physics collaboration LIGO[9] . In addition , general relativity is the basis of current cosmological models of a consistently expanding universe[10] .

However, unanswered questions remain, the most fundamental being how general relativity can be reconciled with the laws of quantum physics to produce a complete and self-consistent theory of quantum gravity[11] .

In this chapter , we will know the gravitational between Newton and Einstein , postulates of general relativity then the mathematical formalism of the theory and finally the Einstein field equation with the constant cosmological .

## 2.2 Gravitational between Newton and Einstein

### 2.2.1 Gravity according to Newton

Gravity According to Newton is a force that works between two objects [12]. So if you have the Earth and the Sun – for example – then the Earth feels a force that is exerted by the Sun , and in turn the Sun feels the same force , exerted by the Earth. The magnitude  $F$  of this force is given by :

$$F = G \frac{m_1 m_2}{r^2} \quad (2.1)$$

Where :

$G$  is the gravitational constant , and equal to  $6.67 \times 10^{-11} N.m^2.Kg^{-2}$

$m_1 , m_2$  are their respective masses

$r$  is the distance between the centres of the Earth and the Sun

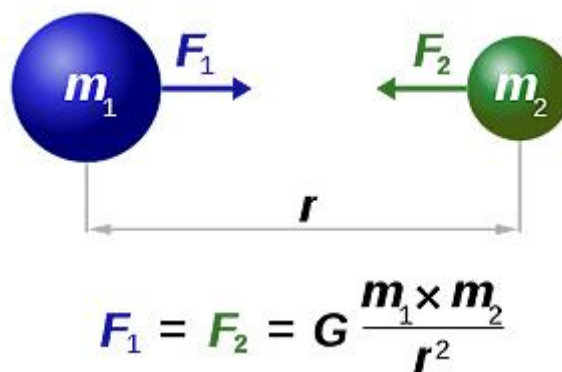

figure 2.1 : The gravitational interaction of two spherical bodies according to Newton[13]

Newton could use his second law to conclude that the force exerted by gravitation is proportional to the mass of the body on which it acts , the third law then ensures that the force is also proportional to the mass of its source [14] .

The forces experienced by Earth and Sun may be equal in magnitude , but the resulting motion is not the same for the two bodies . According to Newton's second law of motion , the magnitude of the acceleration a body experiences when it is subjected to a force is equal to the magnitude of the force divided by the body's mass. Since the Sun's mass is large, the acceleration it experiences due to the Earth's gravitational pull is negligible compared to that experienced by the much less massive Earth. That's why the Sun remains more or less stationary, while the Earth is forced on an orbit around it.

### 2.2.1 Gravity according to Einstein

In 1915, Einstein's quest for a relativistic theory of gravity resulted not in a new force law or a new theory of a relativistic gravitational field , but in a profound conceptual revolution in our views of space and time . Einstein saw that the experimental fact that all bodies fall with the same acceleration in a gravitational field led naturally to an understanding of gravity in terms of the curvature of the four-dimensional union of space and time—spacetime . Mass curves spacetime in its vicinity, and the trajectories along which all masses fall are the straight paths in this curved spacetime[15] .

In Newtonian theory the Sun exerts a gravitational force on the Earth and the Earth moves around the Sun in response to that force . In general relativity the mass of the Sun curves the surrounding spacetime , and the Earth moves on a straight path in that curved spacetime . Gravity is geometry .

We can summarize all this in John Wheeler's quote <<Spacetime tells matter how to move , matter tells spacetime how to curve[16]>> .

## 2.3 Mathematical formalism of general relativity

The mathematics of general relativity refers to various mathematical structures and techniques that are used in studying and formulating Albert Einstein's theory of general relativity. The main tools used in this geometrical theory of gravitation are tensor or tensor fields .

Tensors are a powerful mathematical tool that is used in many areas in engineering and physics including general relativity theory , quantum mechanics , statistical thermodynamics , classical mechanics , electrodynamics , solid mechanics , and fluid dynamics . Laws of physics and physical invariants must be independent of any arbitrarily chosen coordinate system[17] .

Tensor analysis allows us to consider very generalized differential geometries and to investigate how they apply to the universe at large. The merger of differential geometry and spacetime was accomplished in the early 20th century by Dr. Albert Einstein[18] .

so we will use tensor analysis [19] to describe the mathematical form of General relativity .

### 2.3.1 Covariance and contravariance of vectors

We consider a vector space  $\xi$  of dimensions  $n$  subtended by  $n$  basis vector  $\vec{e}_\mu$ ,  $\mu = 0, 1, \dots, n - 1$  as any element  $\vec{v} \in \xi$  is written[20]:

$$\vec{v} = v^\mu \vec{e}_\mu \quad (2.3.1.1)$$

Where :

$v^\mu$  are the components of the vector field  $\vec{v}$  in the basis  $\vec{e}_\mu$

To choose a new basis of  $\xi$  of basis  $(\vec{e}_{\mu'}, \dots, \vec{e}_{\alpha'})$ , this choice is connected as that of the basis  $(\vec{e}_\mu, \dots, \vec{e}_\alpha)$ . The vector  $\vec{v}$  is independent of the choice of the basis, so we can say that the vector is invariant. The components  $v_\mu$  verifying :

$$v_\mu = \vec{v} \cdot \vec{e}_\mu \quad (2.3.1.2)$$

$v_\mu$  are called **covariant components**

$$\vec{v} = v^\mu \cdot \vec{e}_\mu \quad (2.3.1.3)$$

$v^\mu$  are called **contravariant components**

The new components are written :

$$V = \Lambda V \quad \left\{ \begin{array}{l} V^\mu = \Lambda_{\mu'}^\mu V^{\mu'} \longrightarrow \text{Covariant quadrivector} \\ V_\mu = \Lambda_{\mu'}^\mu V'_{\mu'} \longrightarrow \text{Contravariant quadrivector} \end{array} \right.$$

Where :

$$\frac{\partial x^\mu}{\partial x^{\mu'}} = \Lambda_{\mu'}^\mu, \text{ represents an element of matrix transformation for variants } x_\mu .$$

Then :

$$\vec{V} = V^\mu \vec{e}_\mu = V^{\nu'} \vec{e}_{\nu'} = \Lambda^{\nu'}_\alpha V^\alpha \vec{e}_{\nu'} = V^\alpha \Lambda^{\nu'}_\alpha \vec{e}_{\nu'} \quad (2.3.1.4)$$

### Properties

- We suppose that the vector space has a symmetric scalar product of two vectors can then be calculated in the basis  $\vec{e}_\mu$  and defined by :

$$\vec{e}_\mu \cdot \vec{e}_\nu = g_{\mu\nu} \quad (2.3.1.5)$$

Where :

$g_{\mu\nu}$  is the metric tensor

- Thus, quite generally, in a coordinate basis the scalar product of two vectors is given by :

$$\vec{v} \cdot \vec{w} = (v^\mu \vec{e}_\mu) \cdot (w^\nu \vec{e}_\nu) = (\vec{e}_\mu \cdot \vec{e}_\nu) v^\mu w^\nu = g_{\mu\nu} v^\mu w^\nu \quad (2.3.1.6)$$

- We write the dual basis vectors by the relation :

$$\vec{e}^\mu \cdot \vec{e}_\nu = \delta_\nu^\mu g_{\mu\nu} \quad (2.3.1.7)$$

- Using the relation (2.4.1.6) , we can find simple expressions for the contravariant and covariant components of a vector  $v$  , we write :

$$\vec{v} \cdot \vec{e}^\mu = v^\nu \vec{e}_\nu \cdot \vec{e}^\mu = v^\nu \delta_\nu^\mu = v^\mu \quad (2.3.1.8)$$

- We Use the inverse of the matrix  $\Lambda$  for the inverse basic transformation , we put that :

$$\Lambda_{\mu'}^\nu = (\Lambda^{-1})^\nu_{\mu'} \text{ with } \Lambda_{\mu'}^\nu \Lambda^{\mu'}_\alpha = \delta_\alpha^\nu \quad (2.3.1.9)$$

## 2.3.2 Tensors

Tensor calculus is a specific language within the general language of mathematics. It is used to express the concepts of multivariable calculus and its applications in disciplines as diverse as linear algebra , differential geometry , calculus of variations , continuum mechanics , and perhaps tensors' most popular application : general relativity[24] .

Vectors , covectors , and linear operators are all special cases of tensors . We will not attempt to define tensors in abstract terms , but settle for a coordinate based definition, as follows .

An  $(N,M)$ -tensor at a given point in space can be described by a set of numbers with  $N + M$  indices which transforms , upon coordinate transformation given by the matrix  $\Lambda$  , in the following way[23][22][21] :

$$T'^{\alpha_1 \dots \alpha_N}_{\beta_1 \dots \beta_M} = \Lambda_{\mu_1}^{\alpha_1} \dots \Lambda_{\mu_N}^{\alpha_N} (\Lambda^{-1})_{\beta_1}^{\nu_1} \dots (\Lambda^{-1})_{\beta_M}^{\nu_M} T^{\mu_1 \dots \mu_N}_{\nu_1 \dots \nu_M} \quad (2.3.2.1)$$

An  $(N,M)$ -tensor in a three-dimensional manifold therefore has  $3(N+M)$  components . It is contravariant in  $N$  components and covariant in  $M$  components.

## Symmetry and antisymmetry

A tensor  $T$  is called symmetric in the indices  $\mu$  and  $\nu$  if the components are equal upon exchange of the index-values . So , for a 2nd rank contravariant tensor,

$$T^{\mu\nu} = T^{\nu\mu} \text{ (symmetric)} \quad (2.3.2.2)$$

A tensor  $T$  is called anti-symmetric in the indices  $\mu$  and  $\nu$  if the components are equal but opposite upon exchange of the index-values . So, for a 2nd rank contravariant tensor ,

$$T_{\mu\nu} = -T_{\nu\mu} \text{ (anti - symmetric)} \quad (2.3.2.3)$$

## Tensor product

There are several operations on tensors that again produce a tensor. The linear nature of tensor implies that two tensors of the same type may be added together, and that tensors may be multiplied by a scalar with results analogous to the scaling of a vector. On components, these operations are simply performed component-wise. These operations do not change the type of the tensor; but there are also operations that produce a tensor of different type.

Let  $a$  be an  $(N, M)$ -tensor and  $b$  a  $(p, q)$ -tensor. We write the coordinates of the first tensor as  $a_{j_1 \dots j_M}^{i_1 \dots i_N}$  and those of the second tensor as  $b_{j_{M+1} \dots j_{M+q}}^{i_{N+1} \dots i_{N+p}}$ . Note that all indices are distinct within and across tensors. The tensor product  $c = a \otimes b$  is defined as the  $(N + p, M + q)$ -tensor having the coordinates

$$c_{j_1 \dots j_M j_{M+1} \dots j_{M+q}}^{i_1 \dots i_N i_{N+1} \dots i_{N+p}} = a_{j_1 \dots j_M}^{i_1 \dots i_N} b_{j_{M+1} \dots j_{M+q}}^{i_{N+1} \dots i_{N+p}} \quad (2.3.2.4)$$

Let us elaborate more on this definition. The tensor  $c$  is allocated  $n^{N+p+M+q}$  addresses. The  $N+p$  contravariant enits of the address  $i_1 \dots i_N i_{N+1} \dots i_{N+p}$  are subdivided into  $M$  leftmost enits and  $p$  rightmost enits. Similarly, the  $M+q$  covariant enits of the address  $j_1 \dots j_M j_{M+1} \dots j_{M+q}$  are subdivided into  $M$  leftmost enits and  $q$  rightmost enits.

### 2.3.3 Metric Tensor

the metric tensor is the fundamental object in general relativity. It may loosely be thought of as a generalization of the gravitational potential of Newtonian gravitation. The metric captures all the geometric and causal structure of spacetime, being used to define notions such as time, distance, volume, curvature, angle, and separating the future and the past [27].

Spacetime is represented by a four-dimensional differentiable manifold  $M$  and the metric tensor is given as a covariant, second-degree, symmetric tensor on  $M$ , conventionally denoted by  $g$ . Moreover, the metric is required to be nondegenerate with signature  $(-+++)$ . A manifold equipped with such a metric is a type of Lorentzian manifold.

$g$  is a symmetric covariant tensor of rank 2. This tensor is known as the metric tensor. The components of this tensor are [26][25]:

$$g(\vec{e}_\mu, \vec{e}_\nu) = g_{\mu\nu} u^\mu u^\nu \quad (2.3.3.1)$$

$$\vec{u} \cdot \vec{v} = g(\vec{u}, \vec{v}) = g(u^\mu \vec{e}_\mu, u^\nu \vec{e}_\nu) = u^\mu v^\nu g(\vec{e}_\mu, \vec{e}_\nu) = g_{\mu\nu} u^\mu v^\nu \quad (2.3.3.2)$$

Usual notation :

$$\vec{u} \cdot \vec{v} = g_{\mu\nu} u^\mu v^\nu \quad (2.3.3.3)$$

Where :

$g_{\mu\nu}$  is a quantity that contains all the information we need to describe Space or curved surface . In other words , the metric tells us how the spacetime changes from flat spacetime to curvedspacetime[28] .

the matrix representation of  $g_{\mu\nu}$  is :

$$g_{\mu\nu} = \begin{pmatrix} 1 & 0 & 0 & 0 \\ 0 & -1 & 0 & 0 \\ 0 & 0 & -1 & 0 \\ 0 & 0 & 0 & -1 \end{pmatrix} \quad (2.3.3.4)$$

We now define distance along a curve . Let the curve be parameterized by  $\lambda$  Let  $\vec{v}$  be the tangent vector-field of the curve .

The squared distance  $ds^2$  between the points along the curve is defined as :

$$ds^2 = g(\vec{v}, \vec{v})d\lambda^2 \quad (2.3.3.5)$$

gives :

$$ds^2 = g_{\mu\nu} v^\mu v^\nu d\lambda^2 \quad (2.3.3.6)$$

The tangent vector has components  $v^\mu = \frac{dx^\mu}{d\lambda}$  , which gives:

$$ds^2 = g_{\mu\nu} dx^\mu dx^\nu \quad (2.3.3.7)$$

The expression  $ds^2$  is known as the line-element .

The components of the metric depend on the choice of local coordinate system . Under a change of coordinates  $x^\mu$  to  $x^{\mu'}$  .

from the following relation :

$$dx^\mu = \Lambda_{\mu'}^\mu dx^{\mu'} = \frac{dx^\mu}{dx^{\mu'}} dx^{\mu'} \quad (2.3.3.8)$$

the metric components transform as :

$$g_{\mu\nu} dx^\mu dx^\nu = g_{\mu\nu} \Lambda_{\mu'}^\mu \Lambda_{\nu'}^\nu dx^{\mu'} dx^{\nu'} \quad (2.3.3.9)$$

Where :

$$g_{\mu'\nu'} = g_{\mu\nu} \Lambda_{\mu'}^\mu \Lambda_{\nu'}^\nu \quad (2.3.3.9)$$

Finally , we can write :

$$ds^2 = g_{\mu'\nu'} dx^{\mu'} dx^{\nu'} = g_{\mu\nu} dx^\mu dx^\nu \quad (2.3.3.10)$$

The metric in Flat space is :

$$ds^2 = c^2 dt^2 - dx^2 - dy^2 - dz^2 = \eta_{\mu\nu} dx^\mu dx^\nu = g_{\mu\nu} dx^\mu dx^\nu \quad (2.3.3.10)$$

Where :

$\eta_{\mu\nu}$  is the Minkowski metric

The generalization from the flat Minkowski spacetime of special relativity to the curved spacetime of general relativity is made by replacing the Minkowski spacetime metric coefficients  $\eta_{\mu\nu}$  , which are constants, with metric coefficients  $g_{\mu\nu}$  that are function of the coordinates[29] .

## 2.3.4 Christoffel's symbols and covariant derivative

### Christoffel's symbols

The equation for the covariant derivative can be written in terms of Christoffel symbols. The Christoffel symbols find frequent use in Einstein's theory of general relativity, where spacetime is represented by a curved 4-dimensional Lorentz manifold with a Levi-Civita connection. The Einstein field equations – which determine the geometry of spacetime in the presence of matter – contain the Ricci tensor. Since the Ricci tensor is derived from the Riemann tensor, which can be written in terms of Christoffel symbols, a calculation of the Christoffel symbols is essential. Once the geometry is determined, the paths of particles and light beams are calculated by solving the geodesic equations in which the Christoffel symbols explicitly appear .

We note that [30]:

$$\partial_i = \frac{\partial}{\partial x^i} = \vec{e}_i \quad , i = 1, 2, \dots, n \quad (2.3.4.1)$$

These can be used to define the metric tensor:

$$g_{ij} = \vec{e}_i \cdot \vec{e}_j \quad (2.3.4.2)$$

which can in turn be used to define the contravariant basis :

$$\vec{e}^i = \vec{e}_j g^{ij} \quad (2.3.4.3)$$

the general definition given below for the Christoffel symbols of the second kind can be proven to be equivalent to :

$$\Gamma^k_{ij} = \frac{\partial \vec{e}_i}{\partial x^j} \cdot \vec{e}^k = \frac{\partial \vec{e}_i}{\partial x^j} g^{km} \vec{e}_m \quad (2.3.4.4)$$

Christoffel symbols of the first kind can then be found :

$$\Gamma_{kij} = \Gamma^m_{ij} g_{mk} = \frac{\partial \vec{e}_i}{\partial x^j} \cdot \vec{e}_m g_{mk} = \frac{\partial \vec{e}_i}{\partial x^j} \cdot \vec{e}_k \quad (2.4.4.5)$$



Rearranging, we see that :

$$\frac{\partial \vec{e}_i}{\partial x^j} = \Gamma^k_{ij} \vec{e}_k = \Gamma_{kij} \vec{e}^k \quad (2.3.4.6)$$

In this form, it easy to see the symmetry of the lower or last two indices:

$$\Gamma^k_{ij} = \Gamma^k_{ji} \quad \text{and} \quad \Gamma_{kij} = \Gamma_{kji} \quad (2.3.4.7)$$

The same numerical values for Christoffel symbols of the second kind also relate to derivatives of the contravariant basis, as seen in the expression :

$$\frac{\partial \vec{e}_i}{\partial x^j} = -\Gamma^i_{jk} \vec{e}^k \quad (2.3.4.8)$$

Christoffel symbols isn't tensors although his notations[33] .

## Covariant derivative

The covariant derivative is the derivative that under a general coordinate transformation transforms covariantly, that is, linearly via the Jacobian matrix of the coordinate transformation [34] .

The covariant derivative of a quadrivector of contravariant components  $V^\mu$  is defined by[32][31] :

$$\vec{V} = V^\mu \vec{e}_\mu \quad (2.3.4.8)$$

When we use (2.4.4.1), we can write :

$$\partial_\nu \vec{V} = \frac{\partial \vec{V}}{\partial x^\nu} = \frac{\partial}{\partial x^\nu} (V^\mu \vec{e}_\mu) = \frac{\partial V^\mu}{\partial x^\nu} \vec{e}_\mu + V^\mu \frac{\partial \vec{e}_\mu}{\partial x^\nu} \quad (2.3.4.9)$$

When we use (2.4.4.6), we can write :

$$\partial_\nu \vec{V} = \partial_\nu V^\mu \vec{e}_\mu + \Gamma^k_{\nu\mu} V^\mu \vec{e}_k \quad (2.3.4.10)$$

When we change  $\rightarrow \star$  , we write (2.4.4.10) like this :

$$\partial_\nu \vec{V} = \partial_\nu V^k \vec{e}_k + \Gamma^k_{\nu\mu} V^\mu \vec{e}_k = (\partial_\nu V^k + \Gamma^k_{\nu\mu} V^\mu) \vec{e}_k \quad (2.3.4.11)$$

$$\partial_\nu \vec{V} = D_\nu V^\mu \vec{e}_k \quad (2.3.4.12)$$

The covariant derivative of a scalar quantity is :

$$D_\nu \phi = \partial_\nu \phi \quad (2.3.4.13)$$

The covariant derivative of a contravariant vector is :

$$D_\nu V^\mu = \partial_\nu V^\mu + \Gamma^\mu_{\nu k} V^k \quad (2.3.4.14)$$

The covariant derivative of a covariant vector is :

$$D_\nu V_\mu = \partial_\nu V_\mu - \Gamma_{\nu k}^\mu V^k \quad (2.3.4.15)$$

The covariant derivative of a tensor for type (2,0) is :

$$D_\nu T^{\mu k} = \partial_\nu T^{\mu k} + \Gamma_{\nu i}^\mu T^{ik} + \Gamma_{\nu i}^k T^{\mu i} \quad (2.3.4.16)$$

The covariant derivative of a tensor for type (0,2) is :

$$D_\nu T_{\mu k} = \partial_\nu T_{\mu k} - \Gamma_{\nu \mu}^i T_{ik} - \Gamma_{\nu k}^i T_{\mu i} \quad (2.3.4.17)$$

The covariant derivative of a tensor for type (1,1) is :

$$D_\nu T_k^\mu = \partial_\nu T_k^\mu + \Gamma_{\nu i}^\mu T_k^i - \Gamma_{\nu k}^i T_i^\mu \quad (2.3.4.18)$$

In general , the covariant derivative of any kind of tensor is :

$$\begin{aligned} D_\nu T_{\mu k}^{ij} &= \partial_\nu T_{\mu k}^{ij} \\ &+ \Gamma_{\nu l}^i T_{\mu k}^{lj} + \text{a term for each contravariant index} \\ &- \Gamma_{\nu \mu}^l T_{lk}^{ij} - \text{a term for each covariant index} \end{aligned} \quad (2.3.4.19)$$

### The relation between $\Gamma_{\nu\mu}^\lambda$ and $g_{\mu\nu}$

From (2.3.4.17) , we can write :

$$D_\nu g_{\mu k} = \partial_\nu g_{\mu k} - \Gamma_{\nu \mu}^k g_{ik} - \Gamma_{\nu k}^\mu g_{\mu i} \quad (2.3.4.20)$$

When  $D_\nu g_{\mu k} = 0$

$$\text{That's gives : } \begin{cases} \partial_\nu g_{\mu k} = \Gamma_{\nu \mu}^i g_{ik} + \Gamma_{\nu k}^i g_{\mu i} = 0 & (1) \\ \partial_\mu g_{k\nu} = \Gamma_{\mu k}^i g_{i\nu} + \Gamma_{\mu \nu}^i g_{ki} = 0 & (2) \\ \partial_k g_{\mu\nu} = \Gamma_{k\nu}^i g_{i\mu} + \Gamma_{k\mu}^i g_{\nu i} = 0 & (3) \end{cases} \quad (2.3.4.21)$$

By using (2.3.4.21) , we can do (1) + (2) - (3) and  $\Gamma_{\nu\mu}^i = \Gamma_{\mu\nu}^i$  ;  $g_{ik} = g_{ki}$ , and writing :

$$2\Gamma_{\mu\nu}^i g_{ki} = \partial_\nu g_{\mu k} + \partial_\mu g_{k\nu} - \partial_k g_{\mu\nu} \quad (2.3.4.22)$$

By multiplying in  $g^{k\lambda}$  , we can write :

$$\Gamma_{\mu\nu}^i \delta_i^\lambda = \frac{1}{2} g^{k\lambda} (\partial_\nu g_{\mu k} + \partial_\mu g_{k\nu} - \partial_k g_{\mu\nu}) \quad (2.3.4.23)$$

Where :

$$\delta_i^\lambda = g^{k\lambda} g_{ki}$$

We know that :

$$\Gamma_{\mu\nu}^i \delta_i^\lambda = \Gamma_{\mu\nu}^\lambda$$

Finally , we can write (2.3.4.23) :

$$\Gamma_{\mu\nu}^\lambda = \frac{1}{2} g^{k\lambda} (\partial_\nu g_{\mu k} + \partial_\mu g_{k\nu} - \partial_k g_{\mu\nu}) \quad (2.3.4.24)$$

### 2.3.5 Geodesic equation

a geodesic generalizes the notion of a "straight line" to curved spacetime. Importantly, the world line of a particle free from all external, non-gravitational force, is a particular type of geodesic. In other words, a freely moving or falling particle always moves along a geodesic[39] .

consider a particle moving freely under the influence of purely gravitational forces . According to the principle of equivalence , there is a freely falling coordinate system in which its equation of motion is that of a straight line in spacetime , that is[38][36][35] :

$$\frac{\partial^2 \xi^\mu}{\partial s^2} = 0 \quad (2.3.5.1)$$

Where :

$ds^2$  is the proper time ,  $ds^2 = -g_{\mu\nu} d\xi^\mu d\xi^\nu$

We try to derive (2.3.5.1) :

$$\frac{\partial}{\partial s} \left( \frac{\partial \xi^\mu}{\partial s} \right) = 0 \quad (2.3.5.2)$$

$$\frac{\partial}{\partial s} \left[ \frac{\partial \xi^\mu}{\partial x^\nu} \frac{\partial x^\nu}{\partial s} \right] = 0 \quad (2.3.5.3)$$

$$\frac{\partial \xi^\mu}{\partial x^\nu} \frac{\partial^2 x^\nu}{\partial s^2} + \frac{\partial}{\partial s} \left( \frac{\partial \xi^\mu}{\partial x^\nu} \right) \frac{\partial x^\nu}{\partial s} = 0 \quad (2.3.5.4)$$

By multiplying and dividing in  $\partial x^\rho$  in the second limit of the equation , we can write (2.3.5.4) :

$$\frac{\partial \xi^\mu}{\partial x^\nu} \frac{\partial^2 x^\nu}{\partial s^2} + \frac{\partial x^\rho}{\partial s} \frac{\partial}{\partial x^\rho} \left( \frac{\partial \xi^\mu}{\partial x^\nu} \right) \frac{\partial x^\nu}{\partial s} = 0 \quad (2.3.5.5)$$

$$\frac{\partial \xi^\mu}{\partial x^\nu} \frac{\partial^2 x^\nu}{\partial s^2} + \frac{\partial^2 \xi^\mu}{\partial x^\rho \partial x^\nu} \frac{\partial x^\rho}{\partial s} \frac{\partial x^\nu}{\partial s} = 0 \quad (2.3.5.6)$$

By multiplying in  $\frac{\partial x^\alpha}{\partial \xi^\mu}$ , we can write :

$$\frac{\partial x^\alpha}{\partial \xi^\mu} \frac{\partial \xi^\mu}{\partial x^\nu} \frac{\partial^2 x^\nu}{\partial s^2} + \frac{\partial x^\alpha}{\partial \xi^\mu} \frac{\partial^2 \xi^\mu}{\partial x^\rho \partial x^\nu} \frac{\partial x^\rho}{\partial s} \frac{\partial x^\nu}{\partial s} = 0 \quad (2.3.5.7)$$

We put :

$$\Gamma_{\rho\nu}^\alpha = \frac{\partial x^\alpha}{\partial \xi^\mu} \frac{\partial^2 \xi^\mu}{\partial x^\rho \partial x^\nu} \quad (2.3.5.8)$$

Where :

$\Gamma_{\rho\nu}^\alpha$  is the Christoffel symbols

Finally , the geodesic equation is written like this :

$$\frac{\partial^2 x^\alpha}{\partial s^2} + \Gamma_{\rho\nu}^\alpha \frac{\partial x^\rho}{\partial s} \frac{\partial x^\nu}{\partial s} = 0 \quad (2.3.5.9)$$

### 2.3.6 Riemann tensor (curvature tensor )

The Riemann tensor ( or the curvature tensor or Riemann–Christoffelcurvature tensor) is a central mathematical tool in the theory of general relativity and the curvature of spacetime is in principle observable via the geodesic deviation equation . It is one of the most important tensors in general relativity. If it is zero then it means that the space is flat. If it is non-zero then we have a curved space. This tensor is most easily derived by considering the order of double differentiation on tensors [42] .

The Riemann tensor curvature tensor. It plays an essential role in the development of general relativity [43] . Because it tells us everything essential about the curvature of a space [44].

Riemann is the only tensor that can be constructed from the metric tensor and its first and second derivatives [45] .

We can find a solution to the problem of measuring the curvature of a manifold at any point by considering changing the order of covariant differentiation. Covariant differentiation is clearly a generalization of partial differentiation [46] .

The general formula for the change of a vector defined by[41][40] :

$$\Delta V^\mu = V_f^\mu - V_i^\mu = \oint \delta V^\mu = - \oint \Gamma_{\nu\lambda}^\mu V^\nu \partial x^\lambda \quad (2.3.6.1)$$

$$\Gamma_{\nu\lambda}^\mu(x) = \Gamma_{\nu\lambda}^\mu(A) + (x^\alpha - x^\alpha_\nu) \partial_\alpha \Gamma_{\nu\lambda}^\mu + \dots \quad (2.3.6.2)$$

$$V^\nu(x) = V^\nu(A) + (x^\alpha - x_0^\alpha) \partial_\alpha V^\nu + \dots (2.3.6.3)$$

We replace (2.3.6.1) in (2.3.6.3) , and we write :

$$V^\mu(x) = V^\mu(A) - (x^\alpha - x_0^\alpha) \Gamma_{\alpha\beta}^\nu V^\beta + \dots (2.3.6.4)$$

$$\begin{aligned} \Delta V^\mu &= -\Gamma_{\nu\lambda}^\mu(A) V^\nu(A) \oint \partial x^\lambda - \partial_\lambda \Gamma_{\nu\lambda}^\mu(A) V^\nu \left[ \oint x^\alpha \partial x^\lambda - x_0^\nu \oint \partial x^\lambda \right] \\ &+ \Gamma_{\nu\lambda}^\mu(A) \Gamma_{\alpha\beta}^\nu(A) V^\beta(A) \left[ \oint x^\alpha \partial x^\lambda - x_0^\alpha \oint \partial x^\lambda \right] (2.3.6.5) \end{aligned}$$

$$\Delta V^\mu = -\partial_\alpha \Gamma_{\nu\lambda}^\mu(A) V^\nu(A) \left[ \oint x^\alpha \partial x^\lambda \right] + \Gamma_{\nu\lambda}^\mu(A) \Gamma_{\alpha\beta}^\nu(A) V^\beta(A) \left[ \oint x^\alpha \partial x^\lambda \right] (2.3.6.6)$$

$$\Delta V^\mu = [-\partial_\alpha \Gamma_{\nu\lambda}^\mu V^\nu + \Gamma_{\nu\lambda}^\mu \Gamma_{\alpha\beta}^\nu V^\beta] \oint x^\alpha \partial x^\lambda (2.3.6.7)$$

we simplify the integral :

$$\begin{aligned} \oint x^\alpha \partial x^\lambda &= \int_A^B x^\lambda \partial x^\alpha + \int_B^C (x^\alpha + dx^\alpha) dx^\alpha + \dots \\ &= x^\lambda \int_{x^\alpha}^{x^\alpha+dx^\alpha} dx^\alpha + x^\lambda \int_{x^\alpha+dx^\alpha}^{x^\alpha} dx^\alpha + \int_{x^\alpha+dx^\alpha}^{x^\alpha} dx^\lambda dx^\alpha \\ &= dx^\lambda \int_{x^\alpha+dx^\alpha}^{x^\alpha} dx^\alpha \end{aligned} (2.3.6.8)$$

So we write (2.3.6.7) , like this :

$$\Delta V^\mu = [-\partial_\alpha \Gamma_{\nu\lambda}^\mu V^\nu + \Gamma_{\nu\lambda}^\mu \Gamma_{\alpha\beta}^\nu V^\beta] \oint x^\lambda \partial x^\alpha [40][41] (2.3.6.9)$$

$$\Delta V^\mu = [\partial_\alpha \Gamma_{\nu\lambda}^\mu V^\nu - \Gamma_{\nu\lambda}^\mu \Gamma_{\alpha\beta}^\nu V^\beta] \oint x^\alpha \partial x^\lambda [40][41] (2.3.6.10)$$

By combination , we find :

$$\Delta V^\mu = -\frac{1}{2} [\partial_\alpha \Gamma_{\nu\lambda}^\mu - \partial_\lambda \Gamma_{\nu\alpha}^\mu + \Gamma_{\nu\alpha}^\mu \Gamma_{\lambda\beta}^\nu - \Gamma_{\nu\lambda}^\mu \Gamma_{\alpha\beta}^\nu] V^\beta \oint x^\alpha \partial x^\lambda (2.3.6.11)$$

$$\Delta V^\mu = -\frac{1}{2} R_{\nu\lambda\alpha}^\mu V^\beta \oint x^\alpha \partial x^\lambda (2.3.6.12)$$

Where :

$R_{\nu\lambda\alpha}^\mu$  is the Riemann tensor

$$R_{\nu\lambda\alpha}^\mu = \partial_\alpha \Gamma_{\nu\lambda}^\mu - \partial_\lambda \Gamma_{\nu\alpha}^\mu + \Gamma_{\nu\alpha}^\mu \Gamma_{\lambda\beta}^\nu - \Gamma_{\nu\lambda}^\mu \Gamma_{\alpha\beta}^\nu (2.3.6.13)$$

## Properties of the Riemann tensor

The symmetry properties of the curvature tensor can, of course, immediately be picked out from the defining equation (2.3.6.13), or from :

$$R_{\mu\nu\beta\alpha} = \partial_\alpha \Gamma_{\mu\nu\beta} - \partial_\beta \Gamma_{\mu\nu\alpha} - \Gamma_{\beta\nu}^\rho \Gamma_{\mu\rho\alpha} + \Gamma_{\alpha\nu}^\rho \Gamma_{\mu\rho\beta} \quad (2.3.6.14)$$

For completeness, we note that in an arbitrary coordinate system an explicit form for these components is found :

$$R_{\mu\nu\beta\alpha} = \frac{1}{2}(\partial_{\beta\mu} g_{\nu\alpha} - \partial_{\nu\alpha} g_{\mu\beta} - \partial_{\nu\beta} \Gamma_{\mu\alpha} + \partial_{\alpha\mu} g_{\nu\beta}) - g^{\rho\sigma} (\Gamma_{\alpha\sigma\nu} \Gamma_{\mu\rho\alpha} - \Gamma_{\alpha\sigma\nu} \Gamma_{\mu\rho\alpha}) \quad (2.3.6.15)$$

Let us choose some arbitrary point P in the manifold and construct a geodesic coordinate system about this point, the metric  $g_{\mu\nu}$  is :

$$\xrightarrow{g_{\mu\nu}} \eta_{\mu\nu} \begin{cases} \partial_\alpha g_{\alpha\beta} = 0 \Rightarrow \Gamma_{\alpha\beta}^\lambda(P) = 0 \\ \partial_\alpha \partial_\beta g_{\alpha\beta} \neq 0 \Rightarrow \partial_\alpha \Gamma_{\mu\nu}^\lambda(P) \neq 0 \end{cases} \quad (2.3.6.16)$$

We can define :

$$R_{\nu\lambda\alpha}^\mu = \partial_\lambda \Gamma_{\mu\nu}^\alpha - \partial_\nu \Gamma_{\mu\lambda}^\alpha \quad (2.3.6.17)$$

We define :

$$R_{\mu\nu\alpha\beta} = g_{\nu\lambda} R_{\mu\beta\alpha}^\lambda \quad (2.3.6.18)$$

In local coordinate system (with  $\Gamma_{\alpha\beta}^\lambda(p) = 0$ ) :

$$\begin{aligned} R_{\mu\nu\alpha\beta} &= g_{\mu\nu} R_{\nu\alpha\beta}^\lambda \\ &= g_{\mu\lambda} (\partial_\beta \Gamma_{\nu\alpha}^\lambda - \partial_\alpha \Gamma_{\nu\beta}^\lambda) \\ &= g_{\mu\lambda} \left[ \partial_\beta \left( \frac{1}{2} g^{\lambda\rho} (\partial_\nu g_{\alpha\beta} + \partial_\alpha g_{\nu\rho} - \partial_\rho g_{\nu\alpha}) \right) - \partial_\alpha \left( \frac{1}{2} g^{\lambda\rho} (\partial_\nu g_{\beta\rho} + \partial_\beta g_{\nu\rho} - \partial_\rho g_{\nu\beta}) \right) \right] \\ &= \frac{1}{2} (\partial_\alpha \partial_\nu g_{\alpha\mu} + \partial_\alpha \partial_\mu g_{\nu\beta} - \partial_\beta \partial_\mu g_{\nu\alpha} - \partial_\alpha \partial_\nu g_{\beta\mu}) \end{aligned} \quad (2.3.6.19)$$

We can note :

$$\partial_\alpha V^\mu = V^\mu_{,\alpha}$$

$$\partial_\alpha g_{\mu\nu} = g_{\mu\nu, \alpha}$$

$$\partial_\alpha \partial_\beta g_{\mu\nu} = g_{\mu\nu, \alpha\beta}$$

From (2.3.6.19) one may immediately establish the following symmetry properties at P:

1 –Symmetry of indices:

$$R_{\mu\nu, \alpha\beta} = R_{\alpha\beta, \mu\nu} \quad (2.3.6.20)$$

2 – Anti-symmetry in the first pair of indices:

$$R_{\mu\nu,\alpha\beta} = -R_{\nu\mu,\beta\alpha} \quad (2.3.6.21)$$

3 – Anti-symmetry in the second pair of indices:

$$R_{\mu\nu,\alpha\beta} = -R_{\mu\nu,\beta\alpha} \quad (2.3.6.22)$$

4 – the cyclic identity (First Bianchi identity) :

$$R_{\mu\nu\alpha\beta} + R_{\mu\alpha\nu\beta} + R_{\mu\beta\nu\alpha} = 0 \quad (2.3.6.23)$$

### 2.3.7 Ricci tensor

The Riemann tensor is a four-index tensor[48][47]. For many purposes this is not the most useful object, but we can create new tensors by contractions of the Riemann tensor [49] . One of them is the Ricci tensor, which is calculated from the Riemann tensor by contraction on the first and third indices [50].

$$R_{\mu\nu} = R_{\mu\lambda\nu}^{\lambda} \quad (2.3.7.1)$$

Where:

$R_{\mu\nu}$  is the Ricci tensor

### Properties of the Ricci tensor

It follows from the symmetries of the Riemann tensor that  $R_{\mu\nu}$  is symmetric. Indeed:

$$R_{\mu\nu} = R_{\nu\mu} \quad (2.3.7.2)$$

$$R_{\nu\mu} = g^{\alpha\beta} R_{\alpha\nu\beta\mu} = g^{\alpha\beta} R_{\beta\mu\alpha\nu} = g^{\beta\alpha} R_{\beta\mu\alpha\nu} = R_{\mu\alpha\nu}^{\alpha} = R_{\mu\nu} \quad (2.3.7.3)$$

From the definition of the Ricci tensor in terms of the Christoffel symbols , we have the following explicit expression

$$R_{\mu\nu} = R_{\mu\alpha\nu}^{\alpha} = \partial_{\nu}\Gamma_{\mu\nu}^{\lambda} - \partial_{\lambda}\Gamma_{\mu\nu}^{\lambda} + \Gamma_{\mu\lambda}^{\rho}\Gamma_{\rho\nu}^{\lambda} - \Gamma_{\mu\nu}^{\rho}\Gamma_{\rho\lambda}^{\lambda} \quad (2.3.7.4)$$

### Curvature Scalar

There is one more contraction of the Riemann tensor we can perform, namely on the Ricci tensor itself :

$$R = g^{\mu\nu} R_{\mu\nu} = g_{\mu\nu} R^{\mu\nu} = \delta_{\nu}^{\mu} R_{\mu}^{\nu} = R_{\mu}^{\mu} = g^{\alpha\beta} g^{\mu\nu} R_{\alpha\mu\nu\beta} \quad (2.3.7.5)$$

Where :

$R$  is curvature scalar ( or the Ricci scalar)

$$R = g^{\mu\lambda} R_{\mu\rho\lambda}^{\rho} \quad (2.3.7.6)$$

### 2.3.8 Einstein tensor

The covariant derivatives of the Ricci tensor and the curvature scalar obey a particularly important relation[52][51], which will be central to our development of the field equations of general relativity [53] .

We define the Bianchi identities :

$$D_{\rho} R_{\beta\mu\nu}^{\alpha} + D_{\mu} R_{\beta\nu\rho}^{\alpha} + D_{\nu} R_{\beta\rho\mu}^{\alpha} = 0 \quad (2.3.8.1)$$

By contracting on the indices  $\alpha$  and  $\mu$  and using the definition of the Ricci tensor ( $R_{\alpha\beta} = R_{\alpha\lambda\beta}^{\lambda}$ ), we can write (2.3.8.1) :

$$D_{\rho} R_{\beta\nu} + D_{\mu} R_{\beta\nu\rho}^{\alpha} + D_{\nu} R_{\beta\rho\mu}^{\alpha} = 0 \quad (2.3.8.2)$$

We use the Anti-symmetry Property

$$D_{\mu} R_{\beta\rho\mu}^{\mu} = -D_{\nu} R_{\beta\mu\rho}^{\mu} = -D_{\nu} R_{\beta\rho} \quad (2.3.8.3)$$

So we write (2.3.8.2) :

$$D_{\rho} R_{\beta\nu} + D_{\mu} R_{\beta\nu\rho}^{\alpha} - D_{\nu} R_{\beta\rho} = 0 \quad (2.3.8.4)$$

By contracting this with  $g^{\beta\nu}$  we obtain :

$$D_{\rho} g^{\beta\nu} R_{\beta\nu} + D_{\mu} g^{\beta\nu} R_{\beta\nu\rho}^{\mu} - D_{\nu} g^{\beta\nu} R_{\beta\rho} = 0 \quad (2.3.8.5)$$

In another way , we have :

$$\begin{aligned} g^{\beta\nu} R_{\beta\nu\rho}^{\mu} &= g^{\beta\nu} g^{\mu\sigma} R_{\sigma\beta\nu\rho} = -g^{\beta\nu} g^{\mu\sigma} R_{\beta\sigma\nu\rho} = -g^{\beta\nu} g^{\mu\sigma} R_{\nu\beta\sigma\rho} = -g^{\beta\nu} g^{\mu\sigma} R_{\nu\beta\sigma\rho} \\ &= -g^{\mu\sigma} g^{\nu\beta} R_{\nu\beta\sigma\rho} = -g^{\mu\sigma} R_{\beta\sigma\rho}^{\beta} = -g^{\mu\sigma} R_{\sigma\rho} \end{aligned}$$

So (2.3.8.5) , it will be :

$$D_{\rho} R - g^{\sigma\mu} D_{\mu} R_{\sigma\rho} - g^{\beta\nu} D_{\nu} R_{\beta\rho} = 0 \quad (2.3.8.6)$$

$$D_{\rho} R - g^{\beta\nu} D_{\nu} R_{\beta\rho} - g^{\beta\nu} D_{\nu} R_{\beta\rho} = 0 \quad (2.3.8.7)$$

$$D_{\rho} R - 2g^{\beta\mu} D_{\nu} R_{\beta\rho} = 0 \quad (2.3.8.8)$$



By multiplying (2.3.8.8) in  $-\frac{1}{2}$ , we use the symmetry  $R_{\beta\rho} = R_{\rho\beta}$ , and we change indices of notation  $\nu \leftrightarrow \mu$  and  $\rho \leftrightarrow \alpha$ , we can write :

$$g^{\beta\mu} D_\nu R_{\beta\rho} - \frac{1}{2} D_\alpha R = 0 \quad (2.3.8.9)$$

In another way, we have :

$$D_\alpha R = \delta_\alpha^\mu D_\mu R = g_{\alpha\beta} g^{\beta\mu} D_\mu R = g_{\alpha\beta} D^\beta R = D^\beta (g_{\alpha\beta} R)$$

So (2.3.8.9), it will be :

$$D^\beta R_{\beta\alpha} - \frac{1}{2} D^\beta (g_{\alpha\beta} R) = 0 \quad (2.3.8.10)$$

$$D^\beta \left[ R_{\beta\alpha} - \frac{1}{2} R g_{\alpha\beta} \right] = 0 \quad (2.3.8.11)$$

$$D^\beta G_{\alpha\beta} = 0 \quad (2.3.8.11)$$

With :

$G_{\alpha\beta}$  is the Einstein tensor

$$G_{\alpha\beta} = R_{\beta\alpha} - \frac{1}{2} R g_{\alpha\beta} \quad (2.3.8.12)$$

### 2.3.9 Stress – energy tensor

The sources of any gravitational field (matter and energy) is represented in relativity by a type (0, 2) symmetric tensor called the energy–momentum tensor . It is a tensor quantity in physics that describes the density and flux of energy and momentum in spacetime, generalizing the stress tensor of Newtonian physics. It is an attribute of matter, radiation, and non-gravitational force fields [57] .

The stress–energy tensor is the source of the gravitational field in the Einstein field equations of general relativity, just as mass density is the source of such a field in Newtonian gravity . the stress–energy tensor is symmetric[58] .

we note that in the case of a region of space that contains electric and magnetic fields but no matter , the components of the energy–momentum tensor are [56][55][54]:

$$T^{\mu\nu} = \frac{1}{\mu_0} \left( F^\mu_\sigma F^{\nu\sigma} - \frac{1}{4} g^{\mu\nu} F^{\rho\sigma} F_{\rho\sigma} \right) \quad (2.3.9.1)$$

Where :

$F_{\mu\nu}$  is the electromagnetic field tensor ,  $F_{\mu\nu} = \partial_\mu A_\nu - \partial_\nu A_\mu$

Another simple example of an energy–momentum tensor is that of an perfect fluid .  
the components of the energy–momentum tensor of an perfect fluid are :

$$T^{\mu\nu} = \left(\rho + \frac{p}{c^2}\right) u^\mu u^\nu + p g^{\mu\nu} \quad (2.3.9.2)$$

We put :

$$c = 1$$

we can write :

$$T^{\mu\nu} = (\rho + p) u^\mu u^\nu + p g^{\mu\nu} \quad (2.3.9.2)$$

Where :

$\rho$  is the mass–energy density

$P$  is the hydrostatic pressure

$u^\mu$  is the fluid four velocity ,  $u^\mu = \frac{\partial \xi^\mu}{\partial s}$

the energy–momentum tensor of the perfect fluid is represented by the matrix :

$$T^{\mu\nu} = \begin{pmatrix} \rho & 0 & 0 & 0 \\ 0 & p & 0 & 0 \\ 0 & 0 & p & 0 \\ 0 & 0 & 0 & p \end{pmatrix} \quad (2.3.9.3)$$

The next thing to note is that :

$$\begin{aligned} T^\mu_\nu u^\nu &= [(\rho + p)u^\mu u_\nu + p\delta^\mu_\nu]u^\nu \\ &= (\rho + p)u^\mu + pu^\mu \\ &= \rho u^\mu \quad (2.3.9.4) \end{aligned}$$

Also :

$$T_{\mu\nu} u^\mu u^\nu = \rho \quad (2.3.9.5)$$

An important general property of the energy–momentum tensor is that its covariant divergence is zero ; we write :

$$\partial_\mu T^{\mu\nu} = 0 \quad (2.3.9.6)$$

## 2.4 Einstein field equation

General relativity explains gravity as the curvature of spacetime. It's all about geometry . The basic equation of general relativity is called The Einstein field equations (EFE) [59].

The Einstein field equations describe the fundamental interaction of gravitation as a result of spacetime being curved by mass and energy . First published by Einstein in 1915 as a tensor equation . The EFE describe how mass and energy (as represented in the stress–energy tensor) are related to the curvature of spacetime (as represented in the Einstein tensor)[60] .

Similar to the way that electromagnetic fields are determined using charges and currents via Maxwell's equations, the EFE are used to determine the spacetime geometry resulting from the presence of mass–energy and linear momentum, that is, they determine the metric tensor of spacetime for a given arrangement of stress–energy in the spacetime[61] .

The relationship between the metric tensor and the Einstein tensor allows the EFE to be written as a set of non-linear partial differential equations when used in this way [62] .

The Einstein field equations (EFE) may be written in the form :

$$R_{\mu\nu} - \frac{1}{2}g_{\mu\nu}R + \Lambda g_{\mu\nu} = \frac{8\pi G}{c^4}T_{\mu\nu} \quad (2.4.1)$$

Where :

$R_{\mu\nu}$  is the Ricci curvature tensor

$R$  is the scalar curvature

$g_{\mu\nu}$  is the metric tensor

$\Lambda$  is the cosmological constant

$G$  is the gravitational constant , and equal to  $6.67 \times 10^{-11} N.m^2.Kg^{-2}$

$c$  is the speed of light in vacuum , and equal

$T_{\mu\nu}$  is the stress–energy tensor

$k = \frac{8\pi G}{c^4}$  is the Einstein constant

The solutions of the EFE are metric tensors . The EFE being non-linear differential equations for the metric, are often difficult to solve . Metric tensors resulting from cases where the resultant differential equations can be solved exactly for a physically reasonable distribution of energy–momentum are called exact solutions.

Special classes of exact solutions are most often studied as they model many gravitational phenomena, such as rotating black holes and the expanding universe . Examples of important exact solutions include the Schwarzschild solution and the Friedman-Lemaître-Robertson-Walker solution. These equations are used to study phenomena such as gravitational waves.

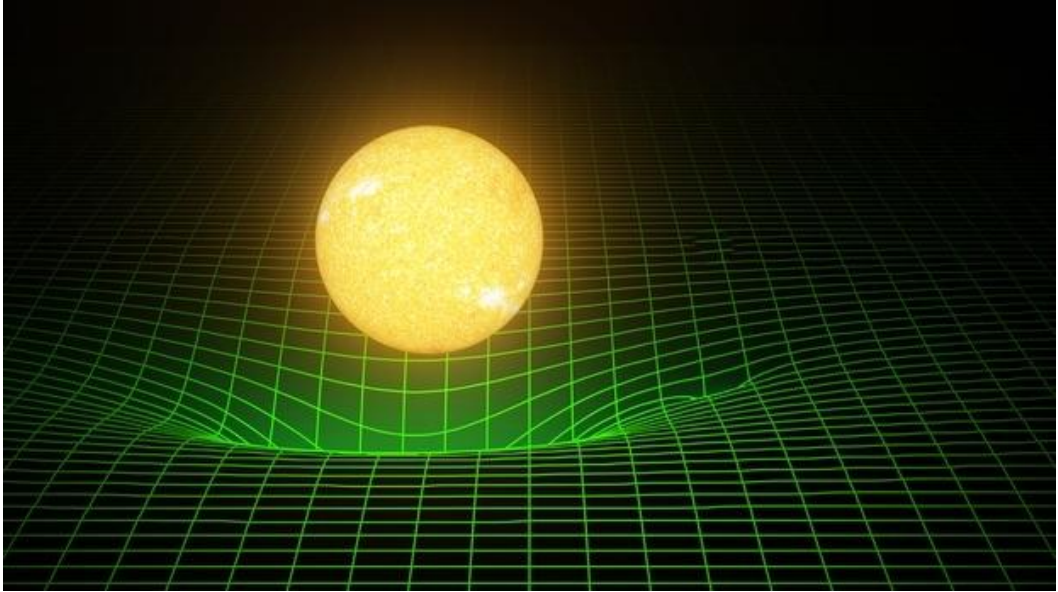

figure 2.1 Massive Bodies Warp Spacetime[63]

### 2.4.1 Derivation of the equation

We begin with the realization that we would like to find an equation which supersedes the Poisson equation for the Newtonian potential[64] [65] :

$$\nabla^2 \phi = 4\pi G \rho (2.4.1.1)$$

Where :

$\nabla^2$  is the Laplacian

$\phi = -\frac{GM}{r}$  is the gravitational potential

$\rho$  is the mass density

The tensor generalization of the mass density is the energy-momentum tensor  $T_{\mu\nu}$ . The gravitational potential should get replaced by the metric tensor  $g_{\mu\nu}$ . It is thus reasonable to guess that the new equation will have  $T_{\mu\nu}$  set proportional to some tensor which is second-order in derivatives of the metric. So we write :

$$\nabla^2 g_{\mu\nu} = 8\pi G T_{\mu\nu} (2.4.1.2)$$

We know that the Riemann tensor is a second derivatives of the metric . It doesn't have the right number of indices, but we can contract it to form the Ricci tensor . and we write:

$$G_{\mu\nu} = 8\pi G T_{\mu\nu} \quad (2.4.1.2)$$

the statement of energy-momentum conservation in curved spacetime should be :

$$\nabla^\mu T_{\mu\nu} = 0 \quad (2.4.1.3)$$

which would then imply :

$$\nabla^\mu G_{\mu\nu} = 0 \quad (2.4.1.3)$$

We know that the Einstein tensor is :

$$G_{\mu\nu} = R_{\mu\nu} - \frac{1}{2} R g_{\mu\nu} \quad (2.4.1.4)$$

from (2.4.1.2) and (2.4.1.4) , we can write :

$$R_{\mu\nu} - \frac{1}{2} R g_{\mu\nu} = 8\pi G T_{\mu\nu} \quad (2.4.1.5)$$

We put :

$$k = \frac{8\pi G}{c^4} \quad (2.4.1.6)$$

from (2.4.1.5) and (2.4.1.6) , we write the Einstein field equation like this :

$$R_{\mu\nu} - \frac{1}{2} R g_{\mu\nu} = k T_{\mu\nu} \quad (2.4.1.7)$$

## 2.4.2 The cosmological constant

in 1917 , Albert Einstein added the cosmological constant  $\Lambda$  to his theory of general relativity [66] .

Einstein included the cosmological constant as a term in his field equations for general relativity because he was dissatisfied that otherwise his equations did not allow for a static universe gravity would cause a universe that was initially at dynamic equilibrium to contract . To counteract this possibility, Einstein added the cosmological constant [67] .

This effort was unsuccessful because:

- the universe described by this theory was unstable
- observations by Edwin Hubble confirmed that our universe is expanding.

So Einstein abandoned the cosmological constant , and calling it the biggest blunder he ever made in his life [68] .

A simple explanation of this phenomenon is provided by the non-vanishing of the cosmological constant in the Einstein equations [69] .

$\Lambda = 0$  ,  $= 0$  : Flat space

$\Lambda > 0$  : Universe contraction

$\Lambda < 0$  : Universe expansion

## 2.5 Schwarzschild metric

The Schwarzschild solution is the unique static, spherically symmetric vacuum spacetime and describes the field outside a spherically symmetric body. It is the most important exact solution of Einstein's field equations [70].

It was found in 1916 by the German physicist Karl Schwarzschild while he was serving on the Russian front during the First World War [71]. Schwarzschild sent his solution to Einstein in latter and concluded the letter by writing : <<As you see , the war treated me kindly enough, in spite of the heavy gunfire , to allow me to in the land of your ideas[72]>> .

### 2.5.1 Deriving the Schwarzschild solution

Einstein's equation should be exactly valid . Therefore it is interesting to search for exact solutions . The simplest and most important one is empty space surrounding a static star or planet. There, one has  $T_{\mu\nu} = 0$  , so the Einstein field equations become[76][75][74][73] :

$$R_{\mu\nu} - \frac{1}{2} g_{\mu\nu} R = 0 \quad (2.5.1.1)$$

Then there is spherical symmetry. Take spherical coordinates :

$$x^0, x^1, x^2, x^3 = (t, r, \theta, \phi)$$

we can express the Minkowski metric in spherical coordinates :

$$ds^2 = c^2 dt^2 - dr^2 - r^2 d\theta^2 - r^2 \sin^2 \theta d\phi^2 \quad (2.5.1.2)$$

We can re-write (2.5.1.2) as the function as :

$$ds^2 = A c^2 dt^2 - B dr^2 - r^2 d\theta^2 - r^2 \sin^2 \theta d\phi^2 \quad (2.5.1.3)$$

Where :

$A$  and  $B$  are functions of the radial coordinate  $r$  alone

In order to correspond to the metric at large  $r$  , we also need to preserve the signature . This can be done by writing the coefficient functions as exponentials , which are guaranteed to be positive functions . That is, we set  $A = e^{2A}$  and  $B = e^{2B}$  . This gives us the metric that is used to obtain the Schwarzschild solution :

$$ds^2 = e^{2A} c^2 dt^2 - e^{2B} dr^2 - r^2 d\theta^2 - r^2 \sin^2 \theta d\phi^2 \quad (2.5.1.4)$$

We know that , metric of the unit sphere is :

$$d\Omega^2 = d\theta^2 + \sin^2 \theta d\phi^2 \quad (2.5.1.5)$$

from (2.5.1.5) , the metric in (3.2.1.4) will be :

$$ds^2 = e^{2A} c^2 dt^2 - e^{2B} dr^2 - r^2 d\Omega^2 \quad (2.5.1.6)$$

We define the metric tensor  $g_{\mu\nu}$  :

$$g_{\mu\nu} = \begin{pmatrix} g_{00} & 0 & 0 & 0 \\ 0 & g_{11} & 0 & 0 \\ 0 & 0 & g_{22} & 0 \\ 0 & 0 & 0 & g_{33} \end{pmatrix} \quad (2.5.1.7)$$

From (2.5.1.7) , we can write (3.2.1.4) like this :

$$g_{\mu\nu} = \begin{pmatrix} e^{2A} & 0 & 0 & 0 \\ 0 & -e^{2B} & 0 & 0 \\ 0 & 0 & -r^2 & 0 \\ 0 & 0 & 0 & -r^2 \sin^2 \theta \end{pmatrix} \quad (2.5.1.8)$$

The inverse metric  $g^{\mu\nu}$  is :

$$g^{\mu\nu} = \begin{pmatrix} e^{-2A} & 0 & 0 & 0 \\ 0 & -e^{-2B} & 0 & 0 \\ 0 & 0 & \frac{-1}{r^2} & 0 \\ 0 & 0 & 0 & \frac{-1}{r^2 \sin^2 \theta} \end{pmatrix} \quad (2.5.1.9)$$

To determine the values of  $e^{2A}$  and  $e^{-2B}$  , first we will have to calculate the following quantities :

- Non-zero Christoffel symbols :

we re-write the Christoffel symbols(2.3.4.24) :

$$\Gamma_{\mu\nu}^{\lambda} = \frac{1}{2} g^{k\lambda} (\partial_{\nu} g_{\mu k} + \partial_{\mu} g_{k\nu} - \partial_k g_{\mu\nu})$$

As an example we calculate  $\Gamma_{00}^1$  , we find :

$$\Gamma_{00}^1 = \frac{1}{2} g^{11} (\partial_0 g_{10} + \partial_0 g_{01} - \partial_1 g_{00}) \quad (2.5.1.10)$$

The final result of all calculations of this type is the following :

$$\begin{aligned} \Gamma_{10}^0 &= \Gamma_{01}^0 = A' \Gamma_{00}^1 = A' e^{2(A-B)} \\ \Gamma_{11}^1 &= B' \Gamma_{22}^1 = -r e^{-2B} \\ \Gamma_{33}^1 &= -e^{-2B} r \sin^2(\theta) \Gamma_{12}^2 = \Gamma_{21}^2 = \frac{1}{r} \end{aligned}$$

$$\Gamma_{33}^2 = -\cos(\theta)\sin(\theta)\Gamma_{13}^3 = \Gamma_{31}^3 = \frac{1}{r}$$

$$\Gamma_{23}^3 = \Gamma_{32}^3 = \frac{1}{\tan(\theta)} = \cot(\theta)$$

Where :

$$\nu' = \frac{dv}{dr}, \quad \mu' = \frac{d\mu}{dr}$$

- Ricci tensor :

we re-write Ricci tensor (2.3.7.4):

$$R_{\mu\nu} = \partial_\nu \Gamma_{\mu\nu}^\lambda - \partial_\lambda \Gamma_{\mu\nu}^\lambda + \Gamma_{\mu\lambda}^\rho \Gamma_{\rho\nu}^\lambda - \Gamma_{\mu\nu}^\rho \Gamma_{\rho\lambda}^\lambda$$

As an example we calculate  $R_{00}$  , we find :

$$R_{00} = \partial_0 \Gamma_{0\lambda}^\lambda - \partial_\lambda \Gamma_{00}^\lambda + \Gamma_{0\lambda}^\rho \Gamma_{\rho 0}^\lambda - \Gamma_{00}^\rho \Gamma_{\rho\lambda}^\lambda \quad (2.5.1.11)$$

The final result of all calculations of this type is the following :

$$R_{00} = -e^{2(A-B)} \left[ A'' + (A')^2 - A'B' + \frac{2A'}{r} \right] \quad (2.5.1.12)$$

$$R_{11} = -e^{2(A-B)} \left[ A'' + (A')^2 - A'B' + \frac{2B'}{r} \right] \quad (2.5.1.13)$$

$$R_{22} = -e^{2B} [1 + r(A' - B')] - 1 \quad (2.5.1.14)$$

$$R_{33} = \sin^2(\theta) [e^{2B} [1 + r(A' - B')] - 1] \quad (2.5.1.15)$$

- curvature scalar :

we re-write curvature scalar(2.3.7.6) :

$$R = g^{\mu\nu} R_{\mu\nu}$$

The final result of calculation of this type is the following :

$$R = g^{00} R_{00} + g^{11} R_{11} + g^{22} R_{22} + g^{33} R_{33} \quad (2.5.1.16)$$

$$R = -2e^{-2B} \left[ A'' + (A')^2 - A'B' + \frac{2}{r}(A' - B') + \frac{1}{r^2} \right] \frac{2}{r^2} \quad (2.5.1.17)$$

- Einstein tensor :

Combining the results for the curvature scalar and the components of the Ricci tensor .we re-write Einstein tensor (2.3.8.12) :

$$G_{\mu\nu} = R_{\mu\nu} - \frac{1}{2} R g_{\mu\nu}$$



As an example we calculate  $R_{00}$  , we find :

$$G_{00} = R_{00} - \frac{1}{2}Rg_{00} \quad (2.5.1.18)$$

The final result of all calculations of this type is the following :

$$G_{00} = -\frac{2e^{2(A-B)}}{r}B' + \frac{e^{2(A-B)}}{r^2} - \frac{e^{2A}}{r^2} \quad (2.5.1.19)$$

$$G_{11} = -\frac{2A'}{r} + \frac{e^{2B}}{r^2} - \frac{1}{r^2} \quad (2.5.1.20)$$

$$G_{22} = -r^2e^{-2B} \left[ A'' + (A')^2 + \frac{(A' - B')}{r} - A'B' \right] \quad (2.5.1.21)$$

$$G_{33} = \sin^2(\theta) G_{22} \quad (2.5.1.22)$$

Now , the vacuum field equations demand that even these Einstein tensor components should each be zero in the space outside the spherically symmetric body . One consequence of this is that :

$$e^{-2A}G_{00} + e^{-2B}G_{11} = 0 \quad (2.5.1.23)$$

$$e^{-2A} \left[ -\frac{e^{2(A-B)}}{r}B' + \frac{e^{2(A-B)}}{r^2} - \frac{e^{2A}}{r^2} \right] + e^{-2B} \left[ -\frac{2A'}{r} + \frac{e^{2B}}{r^2} - \frac{1}{r^2} \right] = 0 \quad (2.5.1.24)$$

$$-\frac{2e^{-2B}}{r}B' + \frac{e^{-2B}}{r^2} - \frac{1}{r^2} - \frac{2e^{-2B}}{r}A' + \frac{1}{r^2} - \frac{e^{-2B}}{r^2} = 0 \quad (2.5.1.25)$$

This implies that :

$$-\frac{2e^{-2B}}{r}B' - \frac{2e^{-2B}}{r}A' = 0 \quad (2.5.1.26)$$

$$\frac{2e^{-2B}}{r}(A' + B') = 0 \quad (2.5.1.27)$$

Implies that :

$$A' + B' = 0 \quad (2.5.1.28)$$

Which can be integrated to give :

$$A + B = C \quad (2.5.1.29)$$

The equation  $G_{00} = 0$  can be rewritten as :

$$\frac{1}{r^2} \frac{d[r(1 - e^{-2B})]}{dr} = 0 \quad (2.5.1.30)$$

We can ignore  $\frac{1}{r^2}$  , and re-write (2.5.1.30) :

$$\frac{d[r - re^{-2B}]}{dr} = 0 \quad (2.5.1.31)$$

$$\frac{dr}{dr} - \frac{dre^{-2B}}{dr} = 0 \quad (2.5.1.32)$$

$$\frac{dre^{-2B}}{dr} = 1 \quad (2.5.1.33)$$

Integrating this equation gives :

$$re^{-2B} = 1(r + K) \quad (2.5.1.34)$$

$$e^{-2B} = 1 + \frac{K}{r} \quad (2.5.1.35)$$

Where :

$K$  is the integration constant

Since  $e^{2A} = e^{-2B}$ , we can now identify the explicit form that must be taken by the two exponential functions in the line element of Equation (3.2.1.4) if the corresponding metric is to satisfy the vacuum field equations. Explicitly :

$$e^{2A} = 1 + \frac{K}{r} \quad (2.5.1.36)$$

$$e^{2B} = \frac{1}{1 + \frac{K}{r}} \quad (2.5.1.37)$$

We define the Newtonian limit :

$$g_{00} = 1 + \frac{2\phi}{c^2} \quad (2.5.1.38)$$

Where :

$\phi = -\frac{GM}{r}$  is the gravitational potential

It follows that in the Newtonian limit :

$$g_{00} = 1 - \frac{2GM}{c^2 r} \quad (2.5.1.39)$$

comparing this(2.5.1.39) result with(2.5.1.36) , we find :

$$K = -\frac{2GM}{c^2} \quad (2.5.1.40)$$

So we re-write (2.5.1.36) and (2.5.1.37) :

$$e^{2A} = 1 - \frac{2GM}{c^2 r} \quad (2.5.1.41)$$

$$e^{2B} = \frac{1}{1 - \frac{2GM}{c^2 r}} \quad (2.5.1.42)$$

We can now represent the metric tensor of the Schwarzschild solution in the diagonal matrix form :

$$g_{\mu\nu} = \begin{pmatrix} 1 - \frac{2GM}{c^2 r} & 0 & 0 & 0 \\ 0 & \frac{1}{1 - \frac{2GM}{c^2 r}} & 0 & 0 \\ 0 & 0 & -r^2 & 0 \\ 0 & 0 & 0 & -r^2 \sin^2 \theta \end{pmatrix} \quad (2.5.1.43)$$

This shows that the line element of the Schwarzschild solution can be written as :

$$ds^2 = \left(1 - \frac{2GM}{c^2 r}\right) c^2 dt^2 - \left(\frac{1}{1 - \frac{2GM}{c^2 r}}\right) dr^2 - r^2 d\theta^2 - r^2 \sin^2 \theta d\phi^2 \quad (2.5.1.44)$$

We put :

$$R_s = \frac{2GM}{c^2} \quad (2.5.1.45)$$

Where :

$R_s$  is the Schwarzschild radius

From (2.5.1.45) , we can re-write (2.5.1.44) :

$$ds^2 = \left(1 - \frac{R_s}{r}\right) c^2 dt^2 - \left(\frac{1}{1 - \frac{R_s}{r}}\right) dr^2 - r^2 d\theta^2 - r^2 \sin^2 \theta d\phi^2 \quad (3.2.1.46)$$

## 2.5.2 Properties of the Schwarzschild solution

The Schwarzschild metric is a static (and therefore stationary) , spherically symmetric solution of the Einstein field equations in the empty region exterior to any distribution of energy and momentum characterized by mass  $M$  that produces purely isotropic effects in that region . The solution is asymptotically flat, approaching the Minkowski metric in spherical coordinates for sufficiently large values of  $r$ . The solution has a coordinate singularity at the Schwarzschild radius  $r = R_s = \frac{2GM}{c^2}$  and a gravitational singularity at  $r = 0$  , though neither of these singularities is within the region described by the solution for normal ‘star-like’ bodies [77] .

Both theoretically and experimentally the Schwarzschild Solution can be studied through the orbits of test particles and light rays . Observations of the small effects predicted by general relativity on the orbits of planets and trajectories of light rays in the solar system are important tests of the theory [78] .

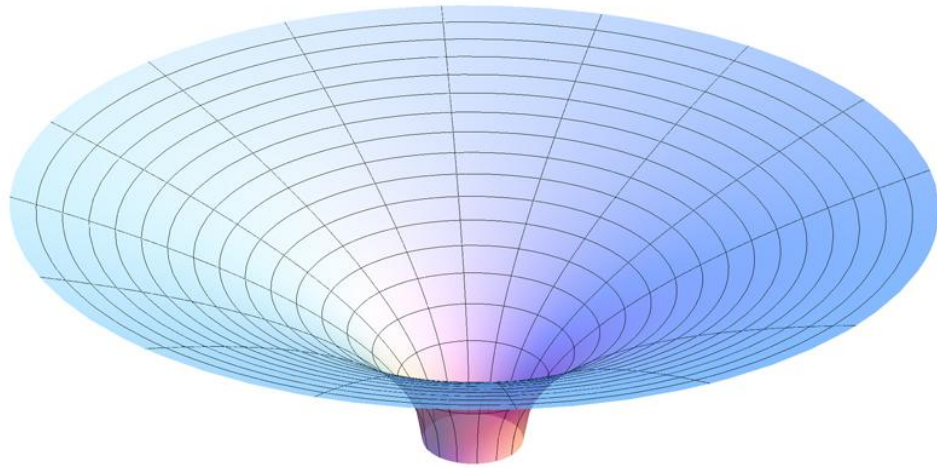

figure 3.1 exterior Schwarzschild solution[79]

## 2.5 Conclusion

The aim of this chapter is to introduce the core ideas of general relativity (Einstein's relativistic theory of gravity) . firstly , we star with a little comparisonbetween the Gravitational of Newton and the Gravitational of Einstein , then wego on to examine the basic Mathematical formalism ( the tensor analysis ) of the theory , also we present the Einstein equation field with the cosmological constant as a new explanation of gravitation , and finally extend the Schwarzschild solution like an exact solution of the Einstein equation field .

# Chapter 03

## Cosmology

**<<Not only is the Universe stranger than we think , it is stranger than we can think>>[1]**

*Werner Heisenberg*

### 3.1 Introduction

<< As Copernicus made the Earth go round the Sun so Friedmann made the Universe expand [2]>> . That how Alexander A. Friedmann described our vision to cosmology .

Cosmology is the study of the dynamics of the entire universe [3] , which give the ability to study global properties such as the structure and temporal evolution of the universe on the largest scale [4] .

The mathematical study of cosmology turns out to be relatively simple for two reasons . The first is that gravity dominates on large scales, so we don't need to consider the local complexity that arises from the nuclear and electromagnetic forces . The second reason is that on large enough scales , the universe is to good approximation homogeneous and isotropic .

Cosmology as a science originated with the Copernican principle , which implies that celestial bodies obey identical physical laws to those on Earth , and Newtonian mechanics , which first allowed us to understand those physical laws . Cosmology – as it is now understood – began with the development in 1915 of Albert Einstein's general theory of relativity[ 5], followed by major observational discoveries in the 1920s: first, Edwin Hubble discovered that the universe contains a huge number of external galaxies beyond our own Milky Way and showed that the universe is expanding [6].

Much of the subject's recent success has been the result of developments in our understanding of the physics of elementary particles and rapid progress in observational astronomy [7] .

Due to the difficulty of performing cosmological experiments and making precise measurements at large distances , many of the most basic questions about the universe are still unanswered today : What actually happened at (or even before) what is usually called the Big Bang ? , is our universe spatially finite or infinite ? , Will our universe keep expanding forever or will it re-collapse ? , What is Dark Matter ? , Is Dark Energy, responsible for what appears to be a current phase of accelerated expansion of the universe, a cosmological constant ?

### 3.1.1 The cosmological principle

Copernicus told us that the Earth is not the center of the solar system . This idea can be generalized to basically say that the Earth is not the center of the universe . We call this statement the cosmological principle .

The cosmological principle is the name given to a powerful simplifying assumption that makes the formulation of relativistic cosmological models tractable [8] . The principle can be stated as follows : on a large enough scale the universe is spatially homogeneous and isotropic [9] .By homogeneity we mean that the properties of the universe are the same at every point in space and by isotropy we mean that being in a given point, in every direction we look at, the properties of the universe look the same [10] .

The validity of the cosmological principle on the largest scales is manifested in a number of different observations, such as number counts of galaxies , and observations of diffuse  $X$ -ray and  $\gamma$ -ray backgrounds , and in the  $2.7^\circ K$  microwave background radiation [11] .

## 3.2 Robertson – Walker metric

The most complete description of the geometrical properties of the Universe is provided by Einstein's general theory of relativity. In General Relativity , the fundamental quantity is the metric which describes the geometry of spacetime .

Around 1935 , Howard Robertson and Arthur Walker showed , independently , that a single spacetime metric underlies all relativistic models that are homogeneous and isotropic [12] . That metric is now known as the Robertson–Walker metric [13] .

The Robertson–Walker metric is an exact solution of Einstein's field equations of general relativity . It describes a homogeneous , isotropic expanding or contracting universe that is path connected , but not necessarily simply connected [14].

We can write the Robertson–Walker metric in its most common form [15] :

$$ds^2 = c^2(dt)^2 - a^2(t) \left[ \frac{(dr)^2}{1 - kr^2} + r^2(d\theta)^2 + r^2 \sin^2 \theta (d\phi)^2 \right] \quad (3.2.1)$$

Where :

$a(t)$  is the scale factor

$k$  is a constant representing the curvature of the space

$k = 0$  the spacetime is flat

$k = -1$  the spacetime is positive curvature

$k = +1$  the spacetime is positive curvature

### 3.3 Friedmann equation

The Friedmann equations are a The Einstein equation with the Robertson–Walker metric and ideal fluid source that govern the expansion of space in homogeneous and isotropic models of the universe [16]. They were first derived by Alexander Friedmann in 1922 from Einstein's field equations of gravitation [17] .

There are two independent Friedmann equations for modeling a homogeneous, isotropic universe . The first is ( with  $c = 1$  ) [18] :

$$\frac{\dot{a}^2 + k}{a^2} = \frac{8\pi G\rho}{3} + \frac{\Lambda}{3} \quad (3.3.1)$$

The second is :

$$\frac{\ddot{a}}{a} = -\frac{4\pi G}{3}(\rho + 3p) + \frac{\Lambda}{3} \quad (3.3.2)$$

Where :

$a$  is the scale factor

$H = \frac{\dot{a}}{a}$  is the Hubble parameter

$G$  is the gravitational constant , and equal to  $6.67 \times 10^{-11} N.m^2.Kg^{-2}$

$k$  is a constant representing the curvature of the space

$\Lambda$  is the cosmological constant

$\rho$  is the mass–energy density

$P$  is the hydrostatic pressure

Using the first equation , the second equation can be re-expressed as :

$$\rho = -3H(\rho + p) \quad (3.3.3)$$

Some cosmologists call the second of these two equations the Friedmann acceleration equation and reserve the term Friedmann equation for only the first equation [19] .

#### 3.3.1 The Density parameter

Whether or not the universe is open or closed is determined by the density of stuff in the universe. In other words, is there enough matter, and therefore enough gravity, to slow down the expansion enough so that it will stop and reverse ? If so, we would live in a closed universe. The density required to have a closed universe is called the critical density [20] . we define it as:

$$\rho_c = \frac{3H^2}{8\pi G} \quad (3.3.1.1)$$

Where :

$$\rho_c = 1.8788 \cdot 10^{-26} h^2 \text{ kg/m}^3$$

The density parameter is then defined as :

$$\Omega = \frac{8\pi G\rho}{3H^2} \quad (3.3.1.2)$$

The density used here is obtained by adding contributions from all possible sources (matter, radiation, vacuum) .

$\Omega < 1$  : the universe is open

$\Omega = 0$  : the universe is flat

$\Omega > 1$  : the universe is close

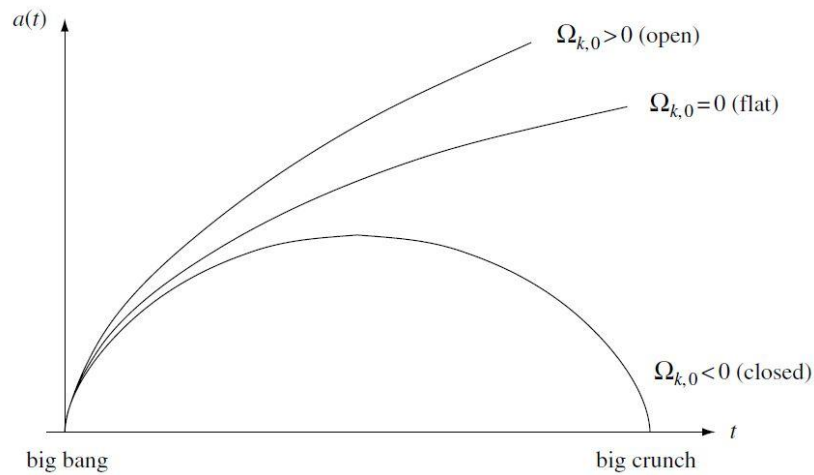

figure 3.1 The evolution of universe in the Friedmann models[21]

### 3.4 Hubble law

Hubble's twin discoveries ( that there are many galaxies in the universe –not just the Milky Way– and that all of those galaxies are traveling out ward , expanding the universe ) rank as the most important astronomical discoveries of the twentieth century [22] . These discoveries radically changed science's view of the cosmos and of our place in it . Hubble's work also represents the first accurate assessment of the movement of stars and galaxies .

Hubble's law is considered the first observational basis for the expansion of the universe and led directly to the discovery of the Big Bang and the origin of the universe as well as to a new concept of time and of the future of the universe [23] . The motion of astronomical objects due solely to this expansion is known as the Hubble flow [24] .



We can write the Hubble law [25] :

$$v = H_0 \cdot D \quad (3.4.1)$$

Where :

$v$  is the recession speed of a given galaxy , typically expressed in ( $Km/s$ )

$H_0$  is the Hubble constant ,  $H_0 = 73.52 \pm 1.62 \frac{Km/s}{Mpc}$ [26]

$D$  is the distance from the galaxy to the observer , measured in mega parsecs ( $Mpc$ )

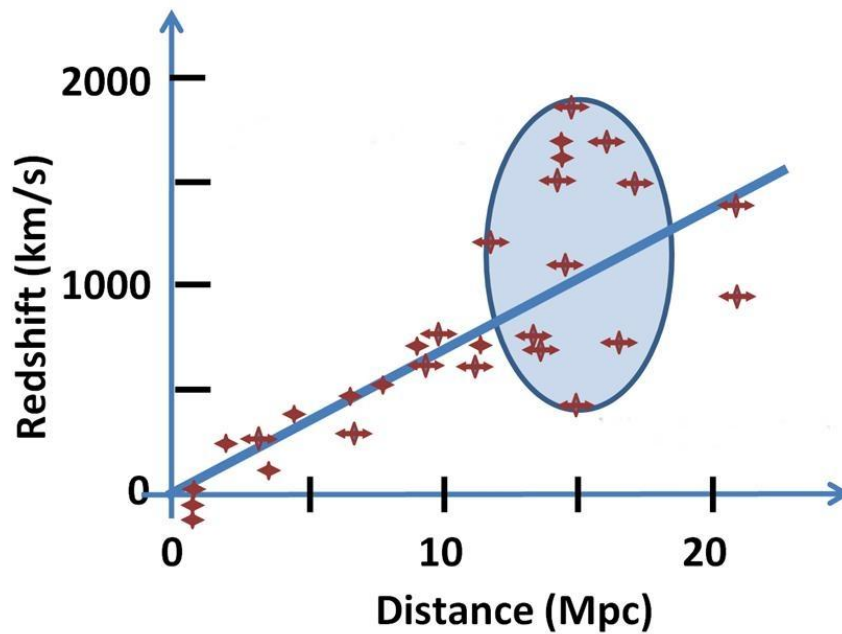

figure 3.2 Scatter plot of fit of redshift to Hubble's law[27]

### 3.4.1 the age of the universe

The Hubble constant has units of inverse time called the Hubble time . It is simply defined as the inverse of the Hubble constant , and write [28] :

$$t_H = \frac{1}{H_0} = \frac{1}{73.52 \frac{Km}{s} / Mpc} \quad (3.4.1.1)$$

Where :

$t_H$  is the Hubble time , measured in second (s)

From the Hubble time , we can know the age of universe , firstly we define :

$$1 pc = 3.0857 \cdot 10^{16} m = 3.0857 \cdot 10^{13} km$$

$$1 year = 31\,556\,926 s$$

We re-write (3.4.1.1) :

$$t_H = \frac{1}{H_0} = \frac{1}{73.52 \frac{\text{Km}}{\text{s}}} \times 3,0857 \cdot 10^{19} \text{ km} \quad (3.4.1.2)$$

$$t_H = 4,197089227 \cdot 10^{17} \text{ s} \quad (3.4.1.3)$$

$$t_H = 13,3 \cdot 10^9 \text{ year} \quad (3.4.1.4)$$

### 3.5 Big bang theory

Modern cosmology is dominated by the Big Bang theory , which brings together observational astronomy and particle physics [29] . The Big Bang theory is the prevailing cosmological model for the universe from the earliest known periods through its subsequent large-scale evolution [30] . The model describes how the universe expanded from a very high-density and high-temperature state , and offers a comprehensive explanation for a broad range of phenomena , including the abundance of light elements , the cosmic microwave background (CMB) , large scale structure and Hubble's law [31] . If the known laws of physics are extrapolated to the highest density regime, the result is a singularity which is typically associated with the Big Bang .

figure 3.3 Cosmic microwave background seen by Planck space telescope [32]

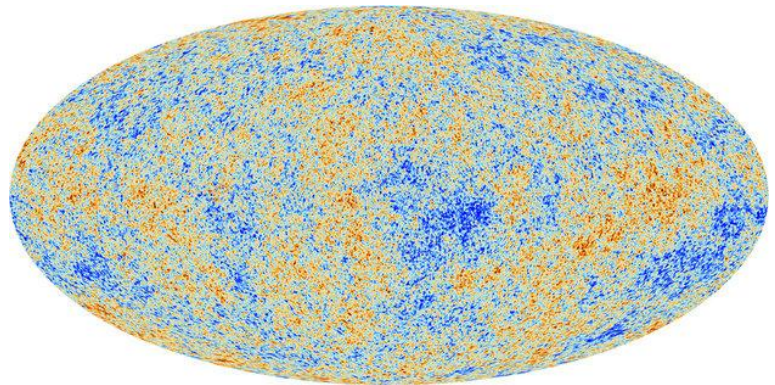

English astronomer Fred Hoyle is credited with coining the term Big Bang during a 1949 BBC radio broadcast , saying : << These theories were based on the hypothesis that all the matter in the universe was created in one big bang at a particular time in the remote past[33]>> .

Physicists are undecided whether this means the universe began from a singularity, or that current knowledge is insufficient to describe the universe at that time . Detailed measurements of the expansion rate of the universe place the Big Bang at around 13.8 billion years ago , which is thus considered the age of the universe [34] .

After the initial expansion, the universe cooled sufficiently to allow the formation of subatomic particles, and later simple atoms . Giant clouds of these primordial elements later coalesced through gravity in halos of dark matter, eventually forming the stars and galaxies visible today [35] . More recently , measurements of the supernovae redshift indicate that the expansion of the universe is accelerating, an observation attributed to dark energy's existence[36].

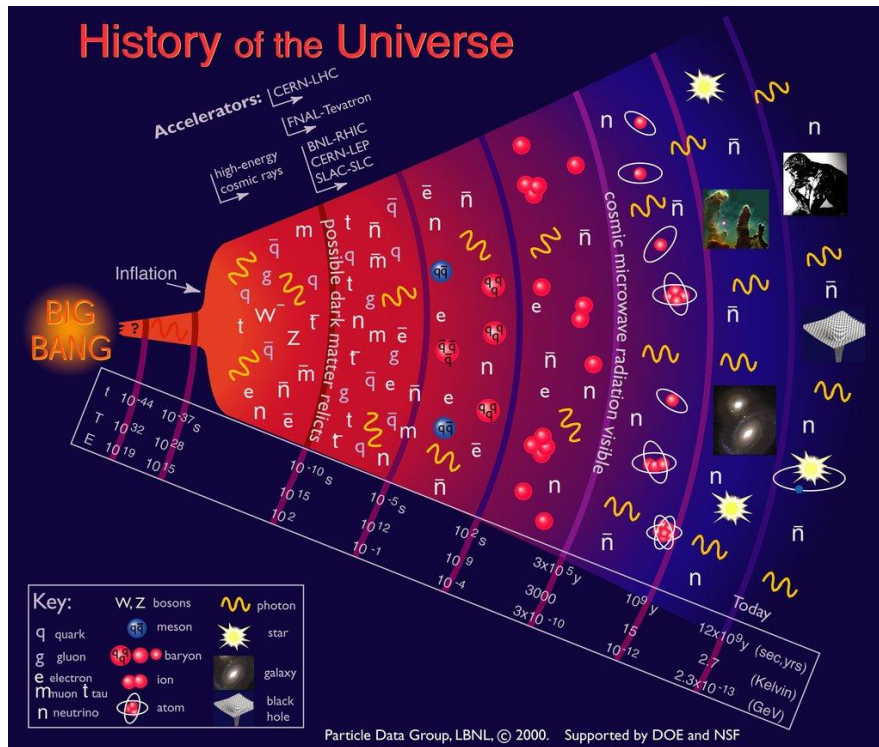

figure 3.4 diagram showing that how the formation of the Universe [37]

Epoch	Time	Radiation temperature (Energy)
Planck epoch	$<10^{-43}$ s	$>10^{32}$ K ( $>10^{19}$ GeV)
Grand unification epoch	$<10^{-36}$ s	$>10^{29}$ K ( $>10^{16}$ GeV)
Inflationary epoch , Electroweak epoch	$<10^{-32}$ s	$10^{28}$ K ~ $10^{22}$ K ( $10^{15}$ ~ $10^9$ GeV)
Quark epoch	$10^{-12}$ s ~ $10^{-6}$ s	$>10^{12}$ K ( $>100$ MeV)
Hadron epoch	$10^{-6}$ s ~ 1 s	$>10^{10}$ K ( $>1$ MeV)
Neutrino decoupling	1 s	$10^{10}$ K (1 MeV)
Lepton epoch	1 s ~ 10 s	$10^{10}$ K ~ $10^9$ K (1 MeV ~ 100 keV)
Big Bang nucleosynthesis	10 s ~ $10^3$ s	$10^9$ K ~ $10^7$ K

		(100 keV ~ 1 keV)
Photon epoch	10 s ~ $1.2 \cdot 10^{13}$ s (380 ky)	$10^9$ K ~ 4000 K (100 keV ~ 0.4 eV)
Recombination	380 ky	4000 K (0.4 eV)
Dark Ages	380 ky ~ 150 My	4000 K ~ 60 K
Reionization	150 My ~ 1 Gy	60 K ~ 19 K
Galaxy formation and evolution	1 Gy ~ 10 Gy	19 K ~ 4 K
Present time	13.3 Gy	2.7 K

Table 3.1 Chronology of the universe

### 3.6 Conclusion

In this chapter , we try to introduce some basic ideas in cosmology , first we introduce The Friedmann–Lemaître–Robertson–Walker model , with Robertson–Walker metric and Friedmann–Lemaître equation, which provided the mathematical description of an expanding universe , also we define Hubble law , which provided the experimental description of an expanding universe, and Finally The Big Bang theory as a standard model of cosmology.

# Chapter 04

## Loop Quantum Gravity

**<<The quest for a quantum gravity is one of the greatest unsolved problems in all of science >>[1]**

*Michio Kaku*

### 4.1 Introduction

How can the theory of quantum mechanics be merged with the theory of general relativity ( gravitational force ) and remain correct at microscopic length scales ? What verifiable predictions does any theory of quantum gravity make ? . It is a big questions that search for a nice answers .

In general relativity, the spacetime metric provides the physical field of gravity and is subject to dynamical laws . For a complete and uniform fundamental description of nature, the gravitational force, and thus spacetime , is to be quantized by implementing the usual features of quantum states , endowing it with quantum fluctuations and imposing the superposition principle . Only then do we obtain a fully consistent description of nature , since matter as well as the non-gravitational forces are quantum , described by quantum stress-energy which can couple to gravity only via some quantum version of the Einstein tensor [2] .

A satisfactory physical theory must combine both of these fundamental principles , quantum mechanics and general relativity , in a consistent way and will be called Quantum Gravity .

The theory of quantum gravity promises a revolutionary new understanding of gravity and spacetime , valid from microscopic to cosmological distances [3]. Research in this field involves an exciting blend of rigorous mathematics and bold speculations, foundational questions and technical issues .

In this chapter , we will know an introduction about Quantum Gravity then the Loop Quantum Gravity theory and their mathematical formalism and finally Loop Quantum Cosmology as an application .

## 4.2 Quantum Gravity

Quantum gravity is the research in theoretical physics that seeks a consistent quantum theory of gravity . It is considered by many as the open problem of paramount importance in fundamental physics, as its task is to unify quantum mechanics (more specifically, quantum field theory, QFT) and general relativity (GR) , which are the two greatest theories discovered in the twentieth century and have become the cornerstones of modern physics [4] . The problem of unifying them is the main open problem in physics left for us to solve in this century [5] .

Eight decades have passed since physicists realized that the theories of quantum mechanics and gravity don't fit together, and the puzzle of how to combine the two remains unsolved [6] . There are a number of proposed quantum gravity theories but researchers have pursued the problem in two separate programs : String Theory and Loop Quantum Gravity [7] .

The necessity of a quantum theory of gravity was pointed out by Albert Einstein already in a 1916 paper . He wrote :

<<Nevertheless, due to the inneratomic movement of electrons, atoms would have to radiate not only electromagnetic but also gravitational energy, if only in tiny amounts. As this is hardly true in Nature, it appears that quantum theory would have to modify not only Maxwellian electrodynamics but also the new theory of gravitation [8]>>.

Today we do not have a theory of quantum gravity , what we have is [9] :

1 – The Standard Model : a quantum theory of the non-gravitational interactions (electromagnetic , weak and strong) or matter which , however, completely ignores general relativity .

2 – Classical General Relativity : which is a background independent theory of all interactions but completely ignores quantum mechanics .

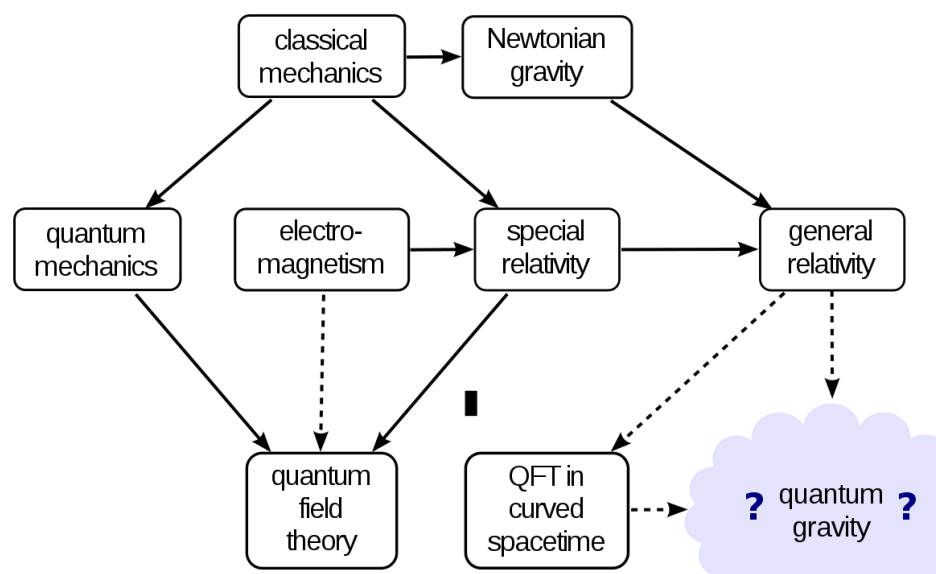

figure 4.1 A diagram showing where quantum gravity sits in the hierarchy of physics theories[10]

Research in Quantum Gravity developed slowly for several decades during the twentieth century, because General Relativity had little impact on the rest of physics and the interest of many theoreticians was concentrated on the development of quantum theory and particle physics. In the past 20 years, the explosion of empirical confirmations and concrete astrophysical, cosmological and even technological applications of General Relativity on the one hand, and the satisfactory solution of most of the particle physics puzzles in the context of the Standard Model on the other, have led to a strong concentration of interest in Quantum Gravity, and the progress has become rapid . Quantum Gravity is viewed today by many as the big open challenge in fundamental physics[11]. There is hope that direct experimental support might come soon, but for the moment either theory could be right, partially right or simply wrong . However, the fact that we have two well developed, tentative theories of quantum gravity is very encouraging . We are not completely in the dark, nor lost in a multitude of alternative theories, and quantum gravity offers a fascinating glimpse of the fundamental structure of nature [12].

### **4.2.1 The need to Quantum Gravity**

Quantum mechanics and General Relativity have extended our understanding of the physical world widely . A large part of physics of the last century has been a triumphant march of exploration of new worlds opened by these two theories [13] .

The very first question about Quantum Gravity is : Why do we even bother to quantize gravity at all ? Apart from many aesthetic considerations for an elegant unification of known fundamental physics , the logical necessity of a quantum description of gravity follows from the conflicts between the two fundamental theories of GR and QFT [14] .

Why should one be interested in developing a quantum theory of the gravitational field ? The main reasons are conceptual [15] .

### **Singularities**

The famous singularity theorems show that the classical theory of general relativity is incomplete: Under very general conditions, singularities are unavoidable. Such singularities can be rather mild, that is, of a purely topological nature, but they can also consist of diverging curvatures and energy densities. In fact, the latter situation seems to be realized in two important physical cases : The Big Bang and black holes. The presence of the cosmic microwave background (CMB) radiation indicates that a Big Bang has happened in the past. Curvature singularities seem to lurk inside the event horizon of black holes. One thus needs a more comprehensive theory to understand these situations .

### **Spacetime**

A theory of gravity is also a theory of spacetime . Quantum gravity should thus make definite statements about the behavior of spacetime at the smallest scales . For this reason it has been speculated long ago that the inclusion of gravity can avoid the divergences that plague ordinary quantum field theories. These divergences arise from the highest momenta

and thus from the smallest scales. This speculation is well motivated. Non-gravitational field theories are given on a fixed background spacetime, that is, on a non-dynamical structure .

## **Black holes thermodynamics**

Also , Classical black holes exhibit a very intriguing thermodynamic behavior , and laws resembling the three laws of thermodynamics characterize their behavior. In particular, one assigns an entropy to black holes which is proportional to their surface area. This observation signals that black holes could have microscopic constituents which are responsible for this entropy. These microscopic constituents are expected to be the degrees of freedom of a suitable quantum theory of gravity , and counting them should result in the black hole's entropy .

### **4.2.2 Spacetime background dependence**

Background independence means that there is no preferred spacetime metric available, rather the metric is a dynamical entity<sup>1</sup> which evolves in tandem with matter, classically according to the Einstein equations. These precisely encode the backreaction<sup>[16]</sup> .

A fundamental lesson of general relativity is that there is no fixed spacetime background, as found in Newtonian mechanics and special relativity ; the spacetime geometry is dynamic. While easy to grasp in principle , this is the hardest idea to understand about general relativity, and its consequences are profound and not fully explored , even at the classical level <sup>[17]</sup> .

One reason why it has taken so long to construct a quantum theory of gravity is that all previous quantum theories were background dependent . It proved rather challenging to construct a background independent quantum theory, in which the mathematical structure of the quantum theory made no mention of points , except when identified through networks of relationships <sup>[18]</sup> .

### **4.2.3 Graviton**

Popularly harmonizing the theory of general relativity that describes gravitation, and applications to large-scale structures like stars, planets, and galaxies with quantum mechanics, that describes the other three fundamental forces acting on the atomic scale, quantum mechanics and general relativity can seem fundamentally incompatible . Also, demonstrations of the structure of general relativity essentially follows inevitably from the quantum mechanics of interacting theoretical spin-2 massless particles called gravitons <sup>[19]</sup> .

The graviton is the hypothetical elementary particle that mediates the force of gravity. There is no complete quantum field theory of gravitons due to an outstanding mathematical problem with renormalization in general relativity.



No concrete proof of gravitons exist, but quantized theories of matter may necessitate their existence .The observation that all fundamental forces except gravity have one or more known messenger particles leads researchers to believe that at least one must exist . This hypothetical particle is known as the graviton .The predicted find would result in the classification of the graviton as a force particle similar to the photon of the electromagnetic interaction [20] .

## 4.3 Loop Quantum Gravity

The challenge for the physicists of the 21st century is to complete the scientific revolution that was started by general relativity and quantum theory . For this we must understand quantum field theory in the absence of a background spacetime . Loop quantum gravity is the most resolute attempt to address this problem [21] .

Loop quantum gravity (LQG) is a theory of quantum gravity , merging quantum mechanics and general relativity . Its goal unifies gravity in a common theoretical framework with the other three fundamental forces of nature , beginning with relativity and adding quantum features [22] . Loop quantum gravity seriously considers general relativity's insight that spacetime is a dynamical field and is therefore a quantum object. Its second idea is that the quantum discreteness that determines the particle-like behavior of other field theories (for instance, the photons of the electromagnetic field) also affects the structure of space .

The main achievement of loop quantization is to quantize gravity as it is geometry . No additional structures are involved. In some sense , it is a minimalistic quantization. On the other hand , it does not include other interactions in nature . It may , of course, be questioned whether a quantum theory of gravity , or better a quantum theory of general relativity has to contain all existing forces [23] .

Another big development of loop quantum gravity is that we now know how to describe not only space but spacetime including causality , light cones , and so on in loop quantum gravity . Spacetime also turns out to be discrete, described by a structure called a spin foam . Recently there have been important results showing that dynamical calculations in Spinfoam models come out finite . Together these two results strongly suggest that loop quantum gravity is giving us sensible answers to questions about the nature of space and time on the shortest scales [24] .

### 4.3.1 Loops

The loops are space because they are the quantum excitations of the gravitational field, which is the physical space. It therefore makes no sense to think of a loop being displaced by a small amount in space. There is only sense in the relative location of a loop with respect to other loops, and the location of a loop with respect to the surrounding space is only determined by the other loops it intersects. A state of space is therefore described by a net of intersecting loops. There is no location of the net, but only location on the net itself; there are

no loops on space, only loops on loops. Loops interact with particles in the same way as, say, a photon interacts with an electron, except that the two are not in space like photons and electrons are[25].

### 4.3.2 Ashtekar variables

Many of the technical problems in canonical quantum gravity revolve around the constraints . Canonical general relativity was originally formulated in terms of metric variables, but there seemed to be insurmountable mathematical difficulties in promoting the constraints to quantum operators because of their highly non-linear dependence on the canonical variables . The equations were much simplified with the introduction of Ashtekars new variables .

In 1986 AbhayAshtekar introduced a new set of canonical variables , The Ashtekar variables (or the Connection representation) to represent an unusual way of rewriting the metric canonical variables on the three-dimensional spatial slices in terms of gauge theories[26] .

One half of Ashtekar's variables are the densitized triads we discussed in the chapter on general relativity ,  $\tilde{E}_i^a$  . The other half behave like an SU(2) Yang-Mills connection  $A_i^a$  and constitute the configuration variables , the densitized triads being their canonically conjugated momentum [28][27]:

$$\{A_i^a(x), \tilde{E}_i^a(x)\} = 8\pi G\beta\delta_b^a\delta_j^i\delta^3(x-y) \quad (4.3.2.1)$$

Where :

$G$  is the gravitational constant

$\beta$  is a constant known as the Immirzi parameter (or Barbero–Immirzi parameter)

The densitized triads can be used to reconstruct the spatial metric via :

$$\tilde{q}^{ab} = \det(q) q^{ab} = \delta^{ij} \tilde{E}_i^a \tilde{E}_j^b = \tilde{E}_i^a \tilde{E}_i^b \quad (4.3.2.2)$$

The connection can be used to reconstruct the extrinsic curvature, which , as we mentioned , is a measure of how the three metric evolves in spacetime . The relation is given by :

$$A_a^i = \Gamma_a^i + \beta k_a^i \quad (4.3.2.3)$$

Where :

$\Gamma_a^i$  is the Spin connection ,  $\Gamma_a^i = \Gamma_{aj k} \epsilon^{jki}$

$K_a^i = k_{ab} \tilde{E}^{ai} / \sqrt{\det(\tilde{q})}$



$\gamma$  is the Immirzi parameter

$j_i$  is the spin associated with the link  $i$  of the spin network

#### 4.3.4 Quantum spacetime : Spinfoam

Loop quantum gravity replaces the Newtonian concept of background space with a history of spin networks called a Spinfoam . Each link in the network is associated with a quantum number of area called “spin”, which is measured in units related to the Planck length[35].

The topological structure of Spinfoam consists of two-dimensional faces representing a configuration required by functional integration to obtain a Feynman's path integral description of Loop quantum gravity [36]. the present Spinfoam Theory has been inspired by the work of Ponzano-Regge model [37].

The aim of the Spinfoam formalism is to provide an explicit tool to compute transition amplitudes in quantum gravity [38].

The summary partition function for a spin foam model is [39]:

$$Z = \sum_{\Gamma} w(\Gamma(\sigma)) \sum_f A_f(j_f) \sum_e A_e(j_f, i_e) \sum_v A_v(j_f, i_e) \quad (4.3.4.1)$$

With :

A set of 2-complexes  $\Gamma$  each consisting out of faces  $f$  , edges  $e$  and vertices  $v$  and a set of irreducible representations  $j$  which label the faces and intertwiners  $i$  which label the edges .

Where :

$w(\Gamma(\sigma))$  is the weight factor

$A_f(j_f)$  is the face amplitude

$A_e(j_f, i_e)$  is the edge amplitude

$A_v(j_f, i_e)$  is the vertex amplitude

$j_f, i_e$  are the colorings adjacent

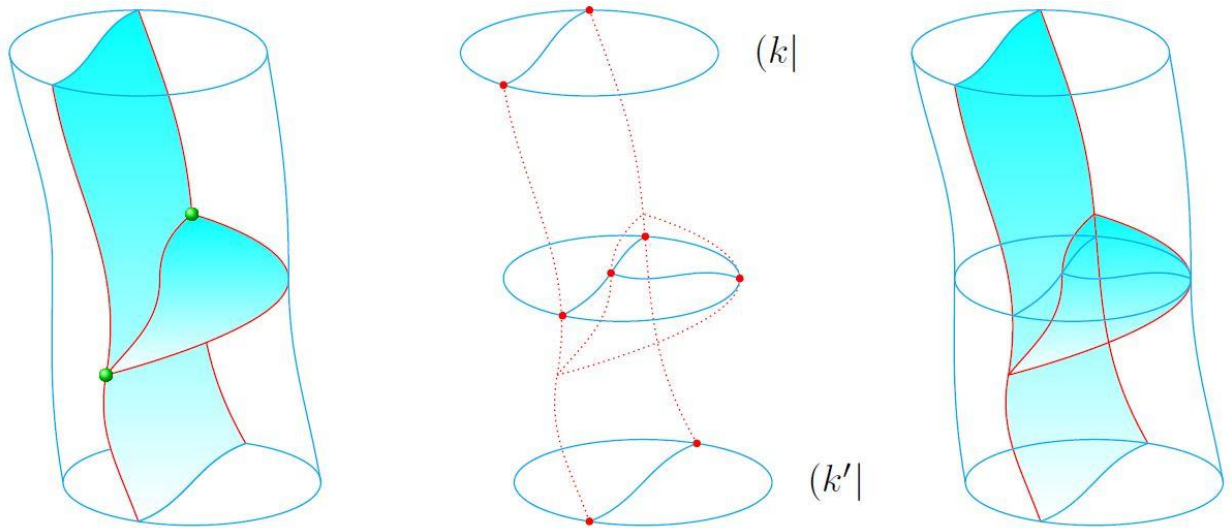

figure 4.3 A simple spin foam composed of 2 vertices , 6 edges , and 6 faces [40]

## 4.4 Loop Quantum Cosmology

Loop quantum cosmology is a finite, symmetry-reduced model of loop quantum gravity that applies principles of the full theory to cosmological settings[41].

The distinguishing feature of Loop quantum cosmology is that the quantum geometry of Loop quantum Gravity gives rise to a brand new quantum force that is inappreciable at low spacetime curvature but rises very rapidly and opposes the classical gravitational force in the Planck regime . As a consequence , for a variety of models of Loop quantum cosmology , the cosmological singularity (big bang , big crunch , big rip , etc.) is avoided by the opposing force , therefore affirming the long-held conviction that singularities in General Relativity signal a breakdown of the classical theory and should be resolved by the quantum effects of gravity . Particularly , the big bang singularity is replaced by a quantum bounce , which bridges the present expanding universe with a preexistent contracting universe. The new cosmological scenario suggests a change of the paradigm in the standard big-bang cosmology.

### 4.4.1 Black hole

<< The black hole epitomizes the revolution wrought by general relativity. It pushes to an extreme — and therefore tests to the limit — the features of general relativity (the dynamics of curved spacetime) that set it apart from special relativity (the physics of static, ‘flat’ spacetime) and the earlier mechanics of Newton [42]>> , that how John Archibald Wheeler described it . So what is black hole ?

A black hole is a place in spacetime where gravity pulls so much that even light can not get out. The gravity is so strong because matter has been squeezed into a tiny space. This can happen when a star is dying [43]. It’s a ‘hole’ because matter and radiation can fall into it. It’s ‘black’ because light is unable to escape from it [44].

The first modern solution of general relativity that would characterize a black hole was found by Karl Schwarzschild in 1916, although its interpretation as a region of space from which nothing can escape was first published by David Finkelstein in 1958. Black holes were long considered a mathematical curiosity; it was during the 1960s that theoretical work showed they were a generic prediction of general relativity [45].

A black hole can't be seen because strong gravity pulls all of the light into the middle of the black hole. But scientists can see how the strong gravity affects the stars and gas around the black hole. Scientists can study stars to find out if they are flying around, or orbiting, a black hole. When a black hole and a star are close together, high-energy light is made. This kind of light can not be seen with human eyes. Scientists use satellites and telescopes in space to see the high-energy light [46].

Black holes of stellar mass are expected to form when very massive stars collapse at the end of their life cycle. After a black hole has formed, it can continue to grow by absorbing mass from its surroundings. By absorbing other stars and merging with other black holes, supermassive black holes of millions of solar masses may form[47].

A black hole can't be seen because strong gravity pulls all of the light into the middle of the black hole. But scientists can see how the strong gravity affects the stars and gas around the black hole. Scientists can study stars to find out if they are flying around, or orbiting, a black hole[48].

figure 4.4 Schwarzschild Black hole[49]

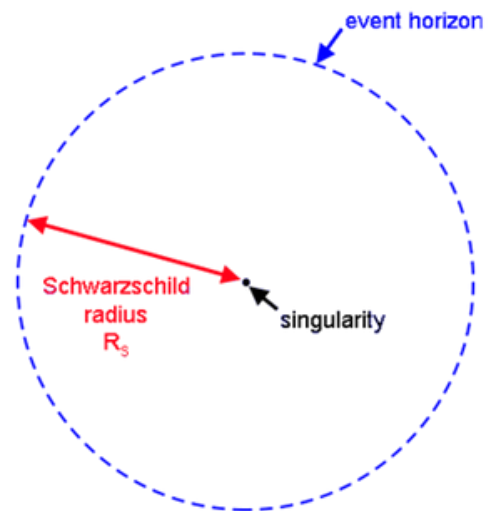

The fact that General Relativity does predict the existence of black holes and that General Relativity is a reliable theory of gravitation does not necessarily prove the existence of black holes, because General Relativity does not describe the astrophysical processes by which a black hole may form [50].

### 3.3.1 The classification of black holes

The basis of the most common classification scheme for black holes is John Wheeler's pronouncement that << a black hole has no hair[51]>>. the no-hair theorem emerged, stating that a stationary black hole solution is completely described by the three parameters: mass, angular momentum and electric charge.

As a consequence, there exists only 4 exact solutions of Einstein's equations describing black hole solutions with or without charge and angular momentum [52]:

- The Schwarzschild solution (1917): has only mass  $M$ ; it is static, spherically symmetric.
- The Reissner-Nordstrom solution (1918): static, spherically symmetric, depends on mass  $M$  and electric charge  $Q$ .

- The Kerr solution (1963) : stationary , axisymmetric , depends on mass and angular momentum .
- The Kerr-Newman solution (1965) : stationary and axisymmetric , depends on all three parameters  $M$  ,  $J$  ,  $Q$  .

	Schwarz	RN	Kerr	Kerr-Newman
Mass	$M > 0$	$M > 0$	$M > 0$	$M > 0$
Charge	$Q = 0$	$Q \neq 0$	$Q = 0$	$Q \neq 0$
Angular momentum	$J = 0$	$J = 0$	$J \neq 0$	$J \neq 0$

Table 4.1 Black hole classifications by  $M$  ,  $J$  ,  $Q$

Another widely used classification scheme for black holes is perhaps more relevant to astrophysics. It is based on the mass of the black hole [53] .

Class	Mass
Mini black holes	0 to $0.1M_{\odot}$
Stellar mass black holes	0.1 to $300M_{\odot}$
Intermediate mass black holes	300 to $10^5M_{\odot}$
Supermassive black holes	$10^5$ to $10^{10}M_{\odot}$

Table 4.2 Black hole classifications by mass

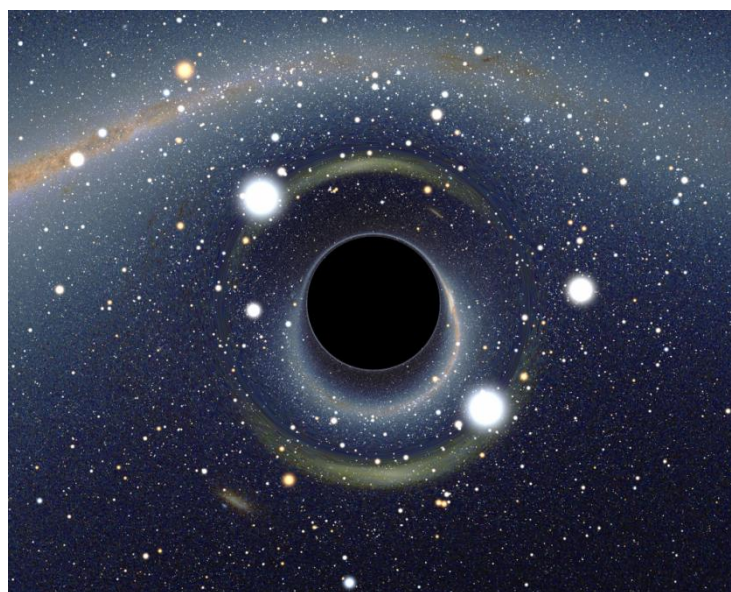

figure 4.5 a Black hole[54]

## 4.5 Conclusion

The main aim of these chapter is to provide with an elementary understanding of loop quantum gravity. at the beginning , we define the quantum gravity and the need to them and the problem of the Background independence of Spacetime, Then we give an introduction for the loop quantum gravity and a basic mathematical formalism of it , and finally we represent the loop quantum cosmology and the black hole as an application of it .



## Summary

In this part of the thesis we studied the original formulation of the bosonic chord, called algebraic chord in order to introduce it into the study of some fundamental aspects of loop quantum gravity.

For this, we have considered the bosonic chord as a toy model on which we can test the quantization methods of quantum loop gravitation.

First of all we were interested in identifying the invariance of parameterization in a one-dimensional space-time and then we went to  $D$  dimensions. Starting from the principle of least action in order to determine the equations of the movement of the two types of strings (open string and closed strings) to the edge condition, using the notation of Green Schwartz, arrived at the transversal Gauge one passes to the stresses in terms of coordinates of open and closed strings in a space. The cords attached at its ends to the  $D$ -brane were started, starting with a single  $D_p$ -brane and then moving on to several parallel  $D_p$ -branes; where the Interactive Gauge field and the possibility of massive Gauge appeared.

Finally, this theory aims to unify the elementary interactions seen previously also, whether on the macroscopic or microscopic scale; it claims that everything would be ropes.

## **History of string theory**

By describing elementary particles as vibrating strings, string theory explains their properties in an elegant way and could even bring together general relativity and quantum mechanics. This catch has been followed for several decades but is bristling with obstacles. Rough mathematically, it is also difficult to verify.

Until the last days before his death, in 1955, Einstein continued his dream of a unified theory of all the forces and particles of matter, and accounting for the laws of quantum mechanics, by means of the geometry of space-time more complex than that of its general relativity. His heirs believe that string theory, still under construction and at and at the working hypothesis stage, is very promising for realizing this dream. In addition to accounting for the mass and charge of particles in the standard model, from the Brought-angler-Higgs boson to the quarks and Leptons, this theory could also account for the nature of the dark matter and the darkness. Black energy. Some in even more spectacular successes; a deep understanding of the origin of the universe and perhaps a technology for making cross worm holes to travel between stars.

It is said that the theory of the strings that it was the physics of the twenty-first century came by chance in the twentieth century as it is difficult to break through its secrets. It is indeed formidable from a mathematical and conceptual point of view, and requires the use of theories as esoteric as algebraic geometry and topology. The equations of string theory are so difficult to solve that the physicist Edward Witten was forced, like Newton at the time, to discover new mathematics. It earned him the Fields Medal, the equivalent of the Nobel Prize in mathematics.

## **Particles can be described as vibrating strings**

String theory originated in the work of Gabriele Veneziano in 1968 when he sought to unravel the mystery of strong nuclear interactions between protons and neutrons. This physicist thus initiated the "resonance model" describing the hadronic particles involved in these interactions. Such as mesons and hyperons. A few years later, the Nobel Prize in physics Yoichiro Nambu and the physicist Leonard Susskind discovered that behind the mathematical equation proposed by Veneziano were hidden cords capable of vibrating and turning on itself.

In the early 1970s, it was discovered with the help of physicists like the French Pierre Ramond and Joel Scherk that these strings open or closed in loops, can represent the particles of matter like quarks, but also the vector particles of the forces, like the photon and the bosons W and Z but especially the mythical graviton. This requires the existence of additional spatial reductions already postulated almost 50 years ago by Theodor Kaluza and Oskar Klein when they sought as Einstein to unify the forces.

We must also postulate the existence of new particles described by a new mathematical theory called super symmetry. The string theory then became super strings. By turning the super strings acquire kinetic moments that are none other than the spins of known particles. Capable of different modes of vibrations like a violin string, they have so many states of energy corresponding to the different masses of the particles, because of the famous equivalence between mass and energy of Einstein.

## **Introduction to string theory**

String theory is one of the most exciting areas of theoretical physics. This ambitious theory is speculative and offers the potential to unify gravity and all other forces of nature and all forms of matter into a unified conceptual structure.

String theory unfortunately has a reputation for being incredibly difficult to understand. To a certain extent, it is because, even for its practitioners, the theory is so new and so poorly understood. However, the basic concepts of string theory are quite simple and should be acceptable to physics students with only advanced training. In this end-of-cycle dissertation thesis part, we first presented a complete remarkable description of string theory, assuming only minimal knowledge of advanced physics, and leads to the current limits of physics, then we have continued the chained demonstrations of all the formulas used to obtain all the physical parameters of the open and closed strings after discussing the classical movement of the closed and open strings. Some exercises have also been started, called quick calculations, inserted in various places in the next chapter and carried to understand the difficulties of the chapter and sometimes to develop new ideas.

# Chapter 05

## String theory

**<<The most important single thing about string theory is that it's a highly mathematical theory , and the mathematics holds together in a very tight and consistent way . It contains in its basic structure both quantum mechanics and the theory of gravity. That's big news>>[1]**

*Leonard Susskind*

Given the great elegance of the classical relativistic string compared to the non-relativistic channel considered previously, we are now beginning to make our study of it.

First, inspired by the case of the point particle, we focus our attention on the surface traced by the rope in space-time. We use the surface area of this surface as the action; it is the action Nambu-Goto. We study the repairing property of this action, identify the tension of the string and find the equations of motion. Thus, for the open string, we focus on the movement of endpoints and introduce the concept of D-branes.

Finally, we see that the only physical movement is transverse to the rope.

### 5-1 Functional Area for Spatial Surfaces

The action for a relativistic string must be a function of the trajectory of the string. Just as a particle draws a line in space-time, a string draws a surface. The line drawn by the particle in space-time is called the world-sheet. A closed chain, for example, will draw a tube, while an open string will draw a band. These two-dimensional world sheets are shown in the space-time diagram in Figure 5.1. The lines of constant  $x^0$  in these surfaces are ropes. These are objects that an observer sees at fixed time  $x^0$ . They are open curves for the surface describing the evolution of the open string (on the left), and they are closed curves for the surface describing the evolution of the closed string (on the right).

We have learned that the action of point particles is proportional to the elapsed time on the world-sheet of point particles. The Lorentz invariance which is "clean length" of the world line is obtained by the time own multiplied by  $c$ . For strings, the Lorentz invariance is defined as "clean zone" of world-sheet. The relativistic string action will be proportional to this own area, and is called the Nambu-Goto action.

Air functions are useful in other applications; for example a soap film between two rings, automatically builds the surface of the minimal area that connects one ring to another (Figure 5.2) very different types of surfaces. At any given moment, a Lorentz observer will see the full two-dimensional surface of the soap film, but he can only see one two-dimensional world-sheet chain. If we imagine that the soap film is static in a Lorentz setting. In this case the time is not relevant for the description of the film, and we consider the film as a spatial surface, namely a surface that extends along two spatial dimensions.

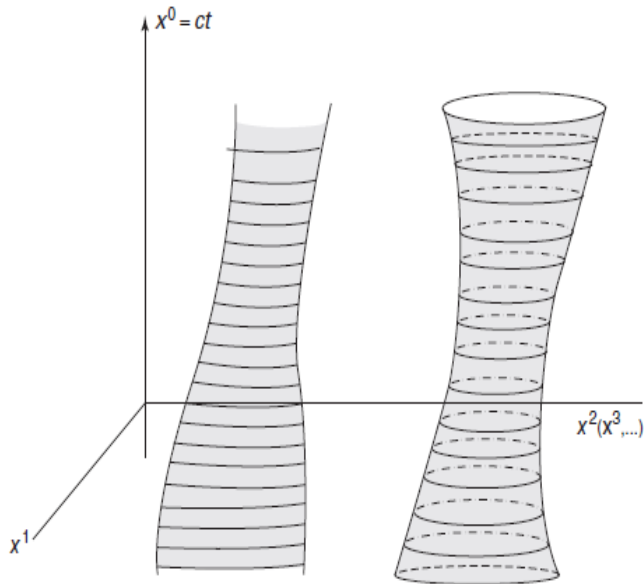

**Figure- 5.1- the leaves of the world drawn by an open string (left) and a closed string (right)**

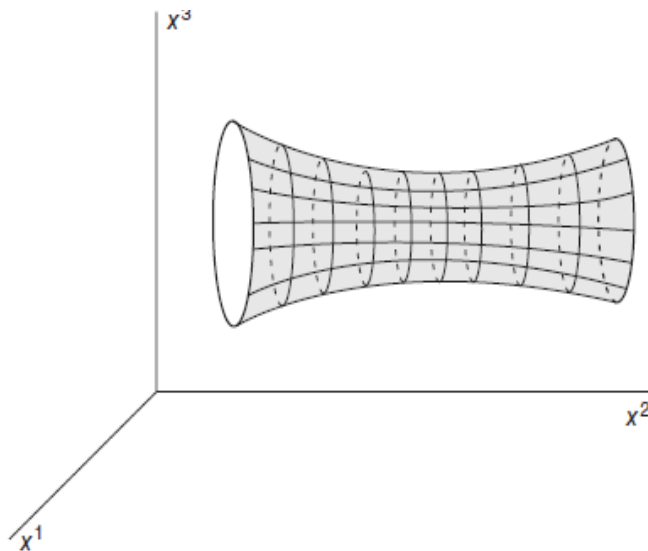

**Figure- 5.2 - Area a space stretch between two rings. If the surface exists in its entirety at any time of the deadline.**

We will first study these familiar surfaces, and then we will apply the experiment to the surfaced case in space-time.

A line in space-time can be parameterized using a single parameter. A surface in space is two-dimensional, so it requires two parameters  $\xi^1$  and  $\xi^2$ . Given a parameterized surface, one can draw on this surface the lines of constant  $\xi^1$  and the lines of constant  $\xi^2$ . These lines open the surface with a grid. The target space is the world where the two-dimensional surface lives. In the case of a three-dimensional soap bubble, the target space is the three-dimensional space  $x^1 x^2 x^3$ . The parameterized area is described by all the functions. A face was a soap film; it would be a minimal area.

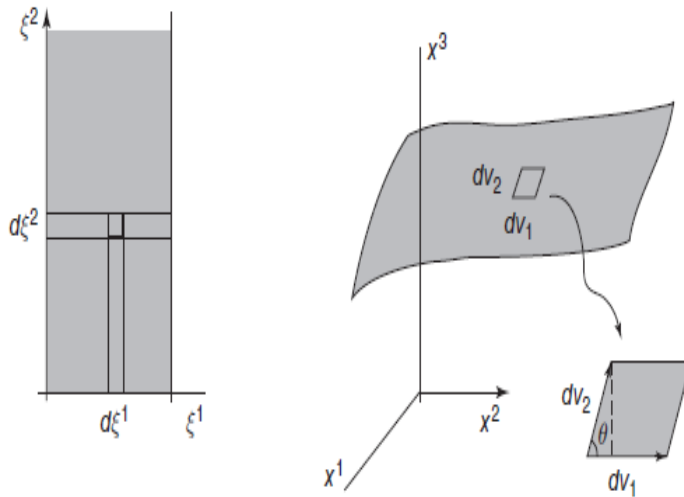

**Figure-5.3-** on the left: the parameter space, with a small rectangle selected. Adroit: the surface of the target space with the image of the small rectangle, a parallelogram whose  $c$ -sides are vectors  $d\vec{v}_1$  and  $d\vec{v}_2$  (displayed enlarged at the end of the wavy arrow)

$$\vec{x}(\xi^1, \xi^2) = (x^1(\xi^1, \xi^2), x^2(\xi^1, \xi^2), x^3(\xi^1, \xi^2)) \quad (5.1)$$

The parameter space is defined by the parameter ranges  $\xi^1$  and  $\xi^2$ . It can be a square; for example, if we use the parameters  $\xi^1, \xi^2 \in [0, \pi]$ . The physical surface is the image of the space of the parameters under the map  $\vec{x}(\xi^1, \xi^2)$ ; it is a surface in the target space. Alternatively, one can see the parameters  $\xi^1$  and  $\xi^2$  entant that coordinated on the physical surface, at least locally. The inverse maps of  $\vec{x}$  takes the surface of the parameter space. Locally, this map is one-to-one and it performs at each point, from the surface two coordinates: the values of the parameters  $\xi^1$  and  $\xi^2$ .

We want to calculate the area of a small element of the surface of the target space. We begin by looking at an infinitesimal rectangle on the parameter space, as we can see its dimensions by  $d\xi^1$  and  $d\xi^2$ . And we try to find  $dA$ , the area of the image of this small rectangle in the large space. As shown in Figure -5.3-, this is the area of the real surface that corresponds to the infinitesimal rectangle of the parameter space.

This element of infinitesimal zone is not necessarily a rectangle. In general, it is a parallelogram. Let's call the dimensions of this parallelogram  $\vec{v}_1$  and  $d\vec{v}_2$ . These are the images under the map  $\vec{x}$  of the vectors  $(d\xi^1, 0)$  and  $(0, d\xi^2)$ , respectively. We can write them

$$d\vec{v}_1 = \frac{\partial \vec{x}}{\partial \xi^1} d\xi^1 d\vec{v}_2 = \frac{\partial \vec{x}}{\partial \xi^2} d\xi^2 \quad (5.2)$$

This has the meaning:  $\partial \vec{x} / \partial \xi^1$ , for example, represent the rate of variation of spatial coordinates with respect to  $\xi^1$ . By multiplying this ratio by the length  $d\xi^1$  of the horizontal side of the small rectangle of parametric space, we obtain the vector  $d\vec{v}_1$  which represents this side in the target space. Then we calculate the surfacedA. Using the formula for the area of a parallelogram:

$$\begin{aligned} dA &= |d\vec{v}_1| |d\vec{v}_2| |\sin \theta| = |d\vec{v}_1| |d\vec{v}_2| \sqrt{1 - \cos^2 \theta} \\ &= \sqrt{|d\vec{v}_1|^2 |d\vec{v}_2|^2 - |d\vec{v}_1|^2 |d\vec{v}_2|^2 \cos^2 \theta} . \end{aligned} \quad (5.3)$$

Where  $\theta$  is the angle between the vectors  $d\vec{v}_1$  and  $d\vec{v}_2$ . In terms of space products, we have,

$$dA = \sqrt{(d\vec{v}_1 \cdot d\vec{v}_1)(d\vec{v}_2 \cdot d\vec{v}_2) - (d\vec{v}_1 \cdot d\vec{v}_2)^2} \quad (5.4)$$

Finally using (6.2)

$$dA = d\xi^1 d\xi^2 \sqrt{\left(\frac{\partial \vec{x}}{\partial \xi^1} \cdot \frac{\partial \vec{x}}{\partial \xi^1}\right) \left(\frac{\partial \vec{x}}{\partial \xi^2} \cdot \frac{\partial \vec{x}}{\partial \xi^2}\right) - \left(\frac{\partial \vec{x}}{\partial \xi^1} \cdot \frac{\partial \vec{x}}{\partial \xi^2}\right)^2} \quad (5.5)$$

This is the general expression of the area element of a parameterized spatial area. Functional area A is given by

$$A = \int d\xi^1 d\xi^2 \sqrt{\left(\frac{\partial \vec{x}}{\partial \xi^1} \cdot \frac{\partial \vec{x}}{\partial \xi^1}\right) \left(\frac{\partial \vec{x}}{\partial \xi^2} \cdot \frac{\partial \vec{x}}{\partial \xi^2}\right) - \left(\frac{\partial \vec{x}}{\partial \xi^1} \cdot \frac{\partial \vec{x}}{\partial \xi^2}\right)^2} \quad (5.6)$$

The integral extends over the relevant ranges of the parameters  $d\xi^1$  and  $d\xi^2$ . The solution of a minimal surface problem for a spatial surface is the function  $\vec{x}(\xi^1, \xi^2)$  which minimizes the function A.



## 5-2- Repair Invariance of the Region

As we have seen, the parameterization of a surface makes it possible to write the element of the area in an explicit form. The area of the surface; or even more, the surface of any part of the surface, should be independent of the parameterization chosen to calculate it, it is what we mean when we say that the zone must be invariant of reparameterization.

Because we will soon assimilate the action of relativistic string to a concept of clean zone, it too, will be invariant repair metrics. This means that we will be free to choose the most useful parameter without changing the underlying physics. A good choice of metrics will solve the equations of the movement of the relativistic string in an elegant way.

Reparametrie invariance is therefore an important concept, one must understand it well. To this end, we try to manifest it in the formulas presented. The purpose of the following analysis is to show how this can be done.

The question that arises first is: Is functional area a (5-6) repaired in variance? We certainly hope that it is.

In fact, at first glance, it seems to be invariant reparameterization. After all; If we repair the surface with  $\xi^1$  ( $\xi^1$ ) and  $\xi^2$  ( $\xi^2$ ), then all the derivatives introduced by the string rule cancel each other appropriately.

This reparameterization above, is not completely general because it fails to mix the coordinates  $\xi^1$  and  $\xi^2$ . On the contrary, we suppose a reparameterization  $\xi^1$  ( $\xi^1, \xi^2$ ) and  $\xi^2$  ( $\xi^1, \xi^2$ )

In order to make the (5.6) manifest repair invariance, the functional area must be rewritten in a different way.

The calculation variable change theorem says that:

$$d\xi^1 d\xi^2 = \left| \det \left( \frac{\partial \xi^i}{\partial \tilde{\xi}^j} \right) \right| d\tilde{\xi}^1 d\tilde{\xi}^2 = |\det M| d\tilde{\xi}^1 d\tilde{\xi}^2. \quad (5.7)$$

Or  $M = [M_{ij}]$  is the matrix defined by  $M_{ij} = (\partial \xi^i) / \partial \tilde{\xi}^j$ . Similarly.

$$d\tilde{\xi}^1 d\tilde{\xi}^2 = \left| \det \left( \frac{\partial \tilde{\xi}^i}{\partial \xi^j} \right) \right| d\xi^1 d\xi^2 = |\det \tilde{M}| d\xi^1 d\xi^2 \quad (5.8)$$

Where  $\tilde{M} = [\tilde{M}_{ij}]$  is the matrix defined by  $\tilde{M}_{ij} = (\partial \tilde{\xi}^i) / (\partial \xi^j)$

By combining equations (5.7) and (5.8), we see that.

$$|\det M| |\det \tilde{M}| = 1 \quad (5.9)$$

We now consider a target surface S described by the mapping functions  $\vec{x}(\xi^1, \xi^2)$ .

Cried by a vector  $d\vec{x}$  tangent to the surface, or we note that  $dS$  is long. So we can write.

$$dS^2 \equiv (dS)^2 = d\vec{x} \cdot d\vec{x} \quad (5.10)$$

The vector  $d\vec{x}$  can be expressed in terms of partial derivatives and the differentials  $d\xi^1, d\xi^2$ :

$$d\vec{x} = \frac{\partial \vec{x}}{\partial \xi^1} d\xi^1 + \frac{\partial \vec{x}}{\partial \xi^2} d\xi^2 = \frac{\partial \vec{x}}{\partial \xi^i} d\xi^i \quad (5.11)$$

Back to (5.10), the repeated index  $i$  summed over its possible values 1 and 2, we can write,

$$dS^2 = \left( \frac{\partial \vec{x}}{\partial \xi^i} d\xi^i \right) \left( \frac{\partial \vec{x}}{\partial \xi^j} d\xi^j \right) = \frac{\partial \vec{x}}{\partial \xi^i} \frac{\partial \vec{x}}{\partial \xi^j} d\xi^i d\xi^j \quad (5.12)$$

We can summarize

$$dS^2 = g_{ij}(\xi) d\xi^i d\xi^j \quad (5.13)$$

Where  $g_{ij}(\xi)$  is defined as

$$g_{ij}(\xi) \equiv \frac{\partial \vec{x}}{\partial \xi^i} \cdot \frac{\partial \vec{x}}{\partial \xi^j} \quad (5.14)$$

The quantity  $g_{ij}(\xi)$  is as under the name metric induced on S? Because,  $\xi^i$  playing the role of coordinates on S, equation (5.13) determines the distances on S.

Since we have only two parameters  $\xi^1$  and  $\xi^2$ , then the complete metric  $g_{ij}$  takes the following form:

$$g_{ij} = \begin{pmatrix} \frac{\partial \vec{x}}{\partial \xi^1} \cdot \frac{\partial \vec{x}}{\partial \xi^1} & \frac{\partial \vec{x}}{\partial \xi^1} \cdot \frac{\partial \vec{x}}{\partial \xi^2} \\ \frac{\partial \vec{x}}{\partial \xi^2} \cdot \frac{\partial \vec{x}}{\partial \xi^1} & \frac{\partial \vec{x}}{\partial \xi^2} \cdot \frac{\partial \vec{x}}{\partial \xi^2} \end{pmatrix} \quad (5.15)$$

The determinant of  $g_{ij}$  is precisely the quantity that appears under the square root in

$$g \equiv \det(g_{ij}) \quad (5.16)$$

We can write

$$A = \int d\xi^1 d\xi^2 \sqrt{g} \quad (5.17)$$

Following the expression (5.17), which is simpler, we are now able to understand the invariance of the zone in terms of transformation property of the metric  $g_{ij}$ . The key to this lies in equation (2.13).

For the set of parameters  $\xi$  and  $\tilde{\xi}(\xi)$ , the following equality must be respected:

$$g_{ij}(\xi) d\xi^i d\xi^j = \tilde{g}_{pq}(\tilde{\xi}) d\tilde{\xi}^p d\tilde{\xi}^q \quad (5.18)$$

Using the string rule to express the differentials  $d\xi$  in terms of differentials  $d\tilde{\xi}$

$$g_{ij}(\xi) d\xi^i d\xi^j = \tilde{g}_{pq}(\tilde{\xi}) \frac{\partial \tilde{\xi}^p}{\partial \xi^i} \frac{\partial \tilde{\xi}^q}{\partial \xi^j} d\xi^i d\xi^j \quad (5.19)$$

Since this result is valid for any variable choice, we find a relation between the metric in  $\xi$  and  $\tilde{\xi}$ :

$$g_{ij}(\xi) = \tilde{g}_{pq}(\tilde{\xi}) \frac{\partial \tilde{\xi}^p}{\partial \xi^i} \frac{\partial \tilde{\xi}^q}{\partial \xi^j} \quad (5.20)$$

Using the definition of M below (5.8), we rewrite the equation above

$$g_{ij}(\xi) = \tilde{g}_{pq} \tilde{M}_{pi} \tilde{M}_{qj} = (\tilde{M}^T)_{ip} \tilde{g}_{pq} \tilde{M}_{qj} . \quad (5.21)$$

In matrix notation, the right-hand side is the product of three matrices.

Take the determinant and use the notation in (5.16) gives

$$g = (\det \tilde{M}^T) \tilde{g} (\det \tilde{M}) = \tilde{g} (\det \tilde{M})^2 \quad (5.22)$$

Take a square root

$$\sqrt{g} = \sqrt{\tilde{g}} |\det \tilde{M}| \quad (5.23)$$

We are now ready to evaluate the reparameterization invariance. Using (5.7), (5.23), and (5.9), we have

$$\int d\xi^1 d\xi^2 \sqrt{g} = \int d\tilde{\xi}^1 d\tilde{\xi}^2 |\det M| \sqrt{\tilde{g}} |\det \tilde{M}| = \int d\tilde{\xi}^1 d\tilde{\xi}^2 \sqrt{\tilde{g}} \quad (5.24)$$

Which proves the invariance of reparameterizing the functional area?

### 5-3 Functional area for the space-time surface

The space-time surface for the ropes case is a two-dimensional surface called the world-sheet of the rope.

They require two parameters. Instead of calling the parameters  $\xi^1$  and  $\xi^2$ , we give them special names:  $\tau$  and  $\sigma$ , given our spatial coordinates  $x^\mu = (x^0, x^1, \dots, x^d)$ , the surface is described by the mapping functions.

$$x^\mu(\tau, \sigma) , \quad (5.26)$$

Which takes a certain region of the parameter space  $(\tau, \sigma)$  in space-time? We will indicate the mapping functions above with the symbols in uppercase

$$X^\mu(\tau, \sigma) \quad (5.27)$$

Given a fixed point  $(\tau, \sigma)$  in the parameter space, this point is mapped to a point with space-time coordinates.

$$(X^0(\tau, \sigma), X^1(\tau, \sigma), \dots, X^d(\tau, \sigma)) \quad (5.28)$$

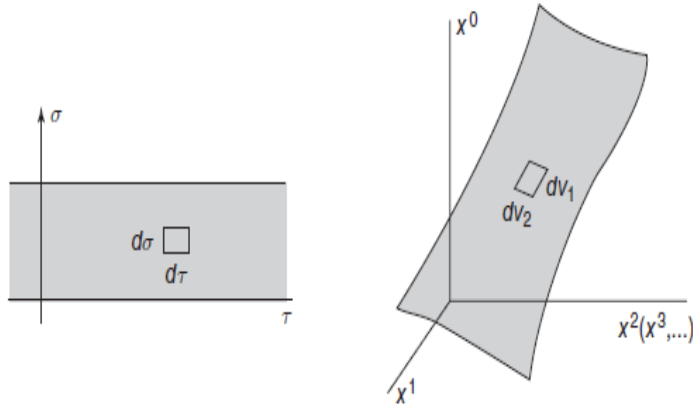

**Figure 5.4 Left: the parameter space ( $\tau$ ,  $\sigma$ ), with a small square selected. On the right: the surface in the target space-time with the image of the small square, a parallelogram whose sides are the vectors  $dV_1^\mu$  and  $dV_2^\mu$**

We can write  $X^\mu$  without the arguments ( $\tau$ ,  $\sigma$ ) knowing that we are talking about the mapping functions of the string. We will call  $X^\mu$  the coordinates of the string as previously, the parameters  $\tau$  and  $\sigma$  can be considered as coordinates on the sheet of the world (world sheet), at least locally. The inverse map of  $X^\mu$  brings the world map back to the parameter space, and locally assigns two coordinates to each point of the surface: the values of the parameters  $\tau$  et  $\sigma$ .

In figure 5.4, we consider an open string: on the left, you see the surface of the parameter space and on the right; you see the surface of the space-time. In this parameter space,  $\sigma$  extends over a finite interval, while  $\tau$  can range from minus infinity to infinity. The parameter  $\tau$  is roughly related to the time on the strings much more on the latter; and the parameter  $\sigma$  is roughly related to the positions along the strings the world lines of the extremities have a constant  $\sigma$ , so they are parametrized by  $\tau$ . When  $\tau$  circulates, the time must elapse. So, at least at the ends.

$$\left. \frac{\partial X^0}{\partial \tau} \right|_{\text{endpoint}} \neq 0 \quad (5.29)$$

We assume that this also holds for other values of  $\sigma$

To find the element of the zone, we proceed as in the case of the spatial surface this time using the relativistic notation. The situation is illustrated in Figure 5.4. A small rectangle of dimension  $d\tau d\sigma$  in the parameter space becomes a quadrilateral element in space-time. This quadrilateral is traversed by the vectors  $dv_1^\mu$  and  $dv_2^\mu$ . Furthermore

$$dv_1^\mu = \frac{\partial X^\mu}{\partial \tau} d\tau, \quad dv_2^\mu = \frac{\partial X^\mu}{\partial \sigma} d\sigma \quad (5.30)$$

Which are analogous to our previous spatial formulas (5.2)? We can now use the analog of (5.4) as candidate for the surface element  $dA$ :

$$dA = \sqrt{(dv_1, dv_1)(dv_2, dv_2) - (dv_1, dv_2)^2} \quad (5.31)$$

Where the point is the relativistic scalar product? The use of this scalar product guarantees that the surface element is invariant to Lorentz: it is an appropriate zone element. Even if it is not yet obvious, the sign of the object under the square root is negative. To be able to take the square root one must exchange the two terms under the square root. This sign change has no effect on the Lorentz invariance. By doing this, and using (5.30). We find that the appropriate area is given as

$$A = \int d\tau d\sigma \sqrt{\left(\frac{\partial X^\mu}{\partial \tau} \frac{\partial X_\mu}{\partial \tau}\right)^2 - \left(\frac{\partial X^\mu}{\partial \tau} \frac{\partial X_\mu}{\partial \sigma}\right) \left(\frac{\partial X^\nu}{\partial \sigma} \frac{\partial X_\nu}{\partial \sigma}\right)} \quad (5.32)$$

Using relativistic scalar product notation

$$A = \int d\tau d\sigma \sqrt{\left(\frac{\partial X}{\partial \tau} \frac{\partial X}{\partial \sigma}\right)^2 - \left(\frac{\partial X}{\partial \tau}\right)^2 \left(\frac{\partial X}{\partial \sigma}\right)^2} \quad (5.33)$$

For:  $\left(\frac{\partial X}{\partial \tau} \frac{\partial X}{\partial \sigma}\right)^2 - \left(\frac{\partial X}{\partial \tau}\right)^2 \left(\frac{\partial X}{\partial \sigma}\right)^2 \geq 0$  at any point on the sheet of the world of a string.

The local characteristics of the space-time surface drawn by a string are: Consider a point on the world map and the entire vectors tangent to the surface at this point. It is stated that in this vector space there is a basis made by two vectors, one of which is similar to space and the other is of temporal type. This implies that at every point of the world leaf there are tangent directions both temporal and spatial. For the fixed-time string case, there may be a finite set of exceptional points where tangents to the world's leaf do not include a time vector. At these points, as we shall see, the rope moves with the speed of light.

Example: Consider Figure (5.5) where we show a piece of rope along the x-axis moving with the speed of light in the y direction. This string at different times closely separated. Any tangent direction of P-sheet is represented by one of these arrows. The tangent world leaf vector associated with PQ is clearly similar to space, since P and Q occur at the same time. The typical tangent that associated with the arrow PR is always on the scale: in the elapsed time, P can reach  $\tilde{R}$  at the speed of light, but arrive at R It must move faster than the light.

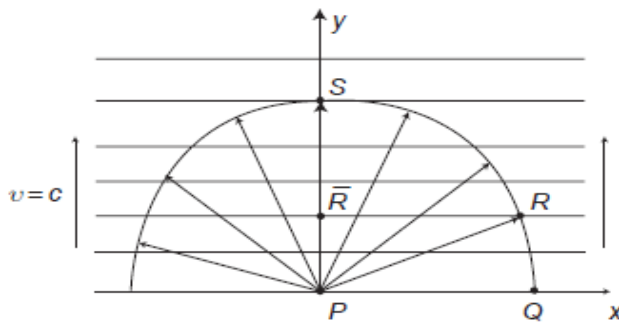

**FIGURE 5.5** a chord along the x direction moving with the speed of light in the y direction. This movement is not allowed. All tangent vectors of the world leaf at any point P of the chain are either spatial or null

All tangent directions are scaled, except the one associated with PS, which is zero. This shows that there is no temporal tangent to P. So there is no temporal vector tangent to the world leaf. Indeed, in our framework, the events defining the chain are simultaneous but spatially separated.

We now consider the world line of a point particle. The vector tangent to the world line of a particle is temporal. At each point of the world line, this tangent vector can be used to describe an instant observer of Lorentz who sees the particular rest. It describes a particle that moves faster than the speed of light. But the string is not made up of constituents whose position we can follow (in exception: we can follow the ends of an open string). However, a tangent close to the world leaf at a given point in a string can describe an instant Lorentz observer who sees the point at rest. If there is a tangent similar to dawn, there are many, by continuity.

Looking at a string at two closely separated moments we cannot tell which point went where, but for each point P on the final string, we must find a point P' on the initial string which could reach P in motion with less of or at most equal to c. The existence of temporal directions and spatial directions at any regular point on the sheet of the world is the criterion for physical movement. This ensures that equation (5.33) makes sense.

**CLAIM:**

At every point P on the leaf of the world where there is both a temporal direction and spatial direction, the quantity under the square root in (5.33) is positive:

$$\left(\frac{\partial X}{\partial \tau} \cdot \frac{\partial X}{\partial \sigma}\right)^2 - \left(\frac{\partial X}{\partial \sigma}\right)^2 \left(\frac{\partial X}{\partial \tau}\right)^2 > 0 \quad (5.34)$$

**EVIDENCE:**

Consider the set of tangent vectors  $v^\mu(\lambda)$  to P obtained as:

$$v^\mu(\lambda) = \frac{\partial X^\mu}{\partial \tau} + \lambda \frac{\partial X^\mu}{\partial \sigma} \quad (5.35)$$

Where  $\lambda \in (-\infty, \infty)$  is a parameter. Since  $(\partial X^\mu) / \partial \tau$  and  $(\partial X^\mu) / \partial \sigma$  are linearly independent tangent vectors, when we vary  $\lambda$ , we get, until constant scales, all vectors tangent to P, including  $(\partial X^\mu) / \partial \sigma$  which is obtained in the limit  $\lambda \rightarrow \infty$  (figure 5.6). The constant scaling of a vector decided if a vector is similar to a time or a space. To determine if  $v^\mu(\lambda)$  is similar to a like volume or a spacelike, we consider its square:

$$v^2(\lambda) = v^\mu(\lambda) v_\mu(\lambda) = \lambda^2 \left(\frac{\partial X}{\partial \sigma}\right)^2 + 2\lambda \left(\frac{\partial X}{\partial \tau} \cdot \frac{\partial X}{\partial \sigma}\right) + \left(\frac{\partial X}{\partial \tau}\right)^2 \quad (5.36)$$

$v^2(\lambda)$  Must take both negative and positive values when  $\lambda$  is different.  $v^2(\lambda) = 0$ , must have two real roots. For this to happen, we see that this requires

$$\left(\frac{\partial X}{\partial \tau} \cdot \frac{\partial X}{\partial \sigma}\right)^2 + \left(\frac{\partial X}{\partial \sigma}\right)^2 \left(\frac{\partial X}{\partial \tau}\right)^2 > 0 \quad (5.37)$$

This is precisely the condition (5.34) that has been tried to prove.

$v^2(\lambda) > 0$ , except for a value of  $\lambda$  where  $v^2$  vanishes. The equation  $v^2(\lambda) = 0$  must have a unique root and the associated discriminated is zero. Any possible movement of the P-string must be associated with a P-sheet tangent of the world. Since motion along spatial directions is non-physical, only the null vector provides an acceptable response: the string moves with velocity light in P.

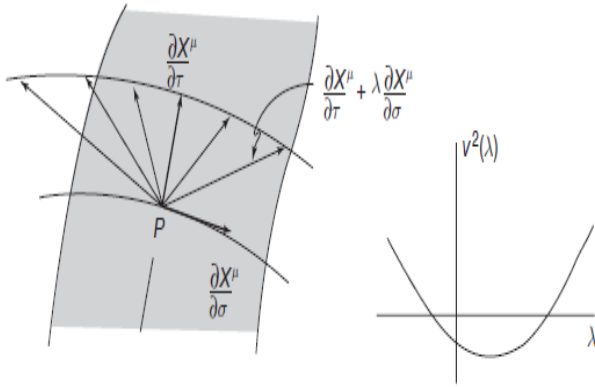

**Figure 5.6: On the left: a set of tangent vectors  $v(\lambda)$  at a point P on the world map. On the right: a graph of  $v^2(\lambda)$  as a function of  $\lambda$ . The vector  $v(\lambda)$  can be of spatial or timelike type depending on the value of  $\lambda$ .**

## 5-4 The action of Numbo-Goto string

After finding the appropriate area and using the following relativistic scalar product notation:

$$A = \int d\tau d\sigma \sqrt{\left(\frac{\partial X}{\partial \tau} \cdot \frac{\partial X}{\partial \sigma}\right)^2 - \left(\frac{\partial X}{\partial \tau}\right)^2 \left(\frac{\partial X}{\partial \sigma}\right)^2}$$

One is sure that the functional zone in (5.33) is correctly defined; one can introduce the action for the relativistic string. This action is proportional to the appropriate area of the world map.

The functional area in (5.33) has units of length squared, as it should be. This is because  $X^\mu$  a unit of length, and each term under the square root has four X. The units of  $\tau$  and of  $\sigma$  cancel each other out. The units of the two terms cancel each other against the units of the differentials. Nevertheless, we will take  $\sigma$  to have units of length and  $\tau$  to have units of time. We do this by anticipating a relation between  $\tau$  and time and between  $\sigma$  and the positions on the strings to sum up:

$$[\tau] = T, [\sigma] = L, [X^\mu] = L, [A] = L^2 \quad (5.38)$$

Since  $\sigma$  must have units of  $ML^2/T$  and  $A$  units of  $L^2$ , the appropriate area must be multiplied by an amount with  $A/T$  units. The tension of the rope  $T_0$  has units of force and the force deviated by the velocity has desired units of  $M/T$ . One can thus multiply the clean surface by  $T_0/c$  to obtain a quantity with the units of action by using (5.33), one defines the action of string equal to

$$S = -\frac{T_0}{c} \int_{\tau_i}^{\tau_f} d\tau \int_0^{\sigma_1} d\sigma \sqrt{(\dot{X} \cdot X')^2 - (\dot{X})^2 (X')^2} \quad (5.39)$$

Here,  $\sigma_1 > 0$  is a constant. And we introduced a notation for derivatives:

$$\dot{X}^\mu \equiv \frac{\partial X^\mu}{\partial \tau}; \quad X^{\mu'} \equiv \frac{\partial X^\mu}{\partial \sigma} \quad (5.40)$$

Action  $S$  is the Nambu-Goto action for the relativistic string.

It is essential that this action be invariant reparameterization.

We can proceed as we did with spatial surfaces to write the Nambu-Goto action in an invariable way by reparameterization. In this case we have

$$-dS = dX^\mu dX_\mu = \eta_{\mu\nu} dX^\mu dX^\nu = \eta_{\mu\nu} \frac{\partial X^\mu}{\partial \xi^\alpha} \frac{\partial X^\nu}{\partial \xi^\beta} d\xi^\alpha d\xi^\beta \quad (5.41)$$

Here  $\eta_{\mu\nu}$  is the Minkowski metric of the target space.

The indices  $\alpha$  and  $\beta$  pass through two values, 1 and 2, and we have taken  $\xi^1 = \tau, \xi^2 = \sigma$ . Just as we did for the spatial surface, we define an induced metric  $\gamma_{\alpha\beta}$  on the sheet of the world:

$$\gamma_{\alpha\beta} \equiv \eta_{\mu\nu} \frac{\partial X^\mu}{\partial \xi^\alpha} \frac{\partial X^\nu}{\partial \xi^\beta} = \frac{\partial X}{\partial \xi^\alpha} \cdot \frac{\partial X}{\partial \xi^\beta} \quad (5.42)$$

More explicitly, the matrix  $2 \times 2$   $\gamma_{\alpha\beta}$  is

$$\gamma_{\alpha\beta} = \begin{bmatrix} (\dot{X})^2 & \dot{X} \cdot X' \\ \dot{X} \cdot X' & (X')^2 \end{bmatrix} \quad (5.43)$$

With the help of this metric, we can write the action Nambu-Goto in the invariant form obviously reparameterization

$$S = -\frac{T_0}{c} \int d\tau d\sigma \sqrt{-\gamma} \quad . \quad \gamma = \det(\gamma_{\alpha\beta}) \quad (5.44)$$

Not only is action (5.44) obviously reparametric, but it is also more compact than (5.39).

In this form, one can easily generalize the Nambu-Goto action to describe the dynamics of objects that have more dimensions than strings. An action of this kind is useful as a first approximation of the dynamics of D-branes.



## 5-5 Movement equations, boundary conditions and D-branes

In this section, we will obtain the equations of motion which follow by the variation of the action of the string. Indeed we will have the opportunity to discuss various boundary conditions that will be interpreted as being due to the existence of D-branes.

We begin by writing the action Nambu-Goto (5.39) as the integral of a Lagrangian density L

$$S = \int_{\tau_i}^{\tau_f} d\tau L = \int_{\tau_i}^{\tau_f} d\tau \int_0^{\sigma_1} d\sigma \mathcal{L}(\dot{X}^\mu, X^{\mu'}) \quad (5.45)$$

Where L is given by

$$\mathcal{L}(\dot{X}^\mu, X^{\mu'}) = -\frac{T_0}{c} \sqrt{(\dot{X}, X')^2 - (\dot{X})^2 (X')^2} \quad (5.46)$$

We can obtain the equations of motion for the relativistic string by putting the variation of the action (5.45) to zero. The variation is simply

$$\delta S = \int_{\tau_i}^{\tau_f} d\tau \int_0^{\sigma_1} d\sigma \left[ \frac{\partial \mathcal{L}}{\partial \dot{X}^\mu} \frac{\partial (\delta X^\mu)}{\partial \tau} + \frac{\partial \mathcal{L}}{\partial X^{\mu'}} \frac{\partial (\delta X^\mu)}{\partial \sigma} \right] \quad (5.47)$$

**Where we used**

$$\delta \dot{X}^\mu = \delta \left( \frac{\partial X^\mu}{\partial \tau} \right) = \frac{\partial (\delta X^\mu)}{\partial \tau} \quad (5.48)$$

And an analogous equation for  $\delta X^{\mu'}$ .

The quantities  $\frac{\partial \mathcal{L}}{\partial \dot{X}^\mu}$  and  $\frac{\partial \mathcal{L}}{\partial X^{\mu'}}$  will appear frequently throughout the rest of the discussion, so it is useful to introduce new symbols for them. That's just what we did when we studied the non-relativistic string and found

$$P_\mu^\tau \equiv \frac{\partial \mathcal{L}}{\partial \dot{X}^\mu} = -\frac{T_0}{c} \frac{(\dot{X}, X') X'_\mu - (X')^2 \dot{X}_\mu}{\sqrt{(\dot{X}, X')^2 - (\dot{X})^2 (X')^2}} \quad (5.49)$$

$$P_\mu^\sigma \equiv \frac{\partial \mathcal{L}}{\partial X^{\mu'}} = -\frac{T_0}{c} \frac{(\dot{X}, X') X'_\mu - (\dot{X})^2 X'_\mu}{\sqrt{(\dot{X}, X')^2 - (\dot{X})^2 (X')^2}} \quad (5.50)$$

Using this notation, the variation  $\delta S$  in (5.47) becomes (5.51)

$$\delta S = \int_{\tau_i}^{\tau_f} d\tau \int_0^{\sigma_1} d\sigma \left[ \frac{\partial}{\partial \tau} (\delta X^\mu P_\mu^\tau) + \frac{\partial (\delta X^\mu P_\mu^\sigma)}{\partial \sigma} - \delta X^\mu \left( \frac{\partial P_\mu^\tau}{\partial \tau} \right) + \left( \frac{\partial P_\mu^\sigma}{\partial \sigma} \right) \right] \quad (5.51)$$

The first term on the right side, being a complete derivative in t, will give terms proportional to  $\delta X^\mu(t_f, \sigma)$  and  $\delta X^\mu(t_i, \sigma)$ . Since the flux of  $\tau$  implies the passage of time, we can imagine specifying the initial and final states of the string, and we restrict ourselves to the variations for which  $\delta X^\mu(t_f, \sigma) = \delta X^\mu(t_i, \sigma) = 0$ . The variation then becomes

$$\delta S = \int_{\tau_i}^{\tau_f} d\tau \left[ \delta X^\mu P_\mu^\sigma \right] - \int_{\tau_i}^{\tau_f} d\tau \int_0^{\sigma_1} d\sigma \delta X^\mu \left( \frac{\partial P_\mu^\tau}{\partial \tau} + \frac{\partial P_\mu^\sigma}{\partial \sigma} \right) \quad (5.52)$$

Since the second term on the right side must disappear for all the variations  $\delta X^\mu$  on the movement, we put

$$\frac{\partial P_\mu^\tau}{\partial \tau} + \frac{\partial P_\mu^\sigma}{\partial \tau} = 0 \quad (5.53)$$

This is the equation of motion for the relativistic string, open or closed. This equation is so complicated. The key to its solution lies in the invariance of reparameterization of the Nambu-Goto action.

The first term on the right side of (5.52) concerns the ends of the string. It is, in fact, a collection of terms that includes two terms for each value of the index. More explicitly, the list

$$\int_{\tau_i}^{\tau_f} d\tau \left( \delta X^0(\tau, \sigma_1) P_0^\sigma(\tau, \sigma_1) - \delta X^0(\tau, 0) P_0^\sigma(\tau, 0) + \delta X^1(\tau, \sigma_1) P_1^\sigma(\tau, \sigma_1) - \delta X^1(\tau, 0) P_1^\sigma(\tau, 0) + \dots \dots \delta X^d(\tau, \sigma_1) P_d^\sigma(\tau, \sigma_1) - \delta X^d(\tau, 0) P_d^\sigma(\tau, 0) \right) \quad (5.54)$$

The boundary conditions for each term of the above is a total of  $2D = 2(d + 1)$  boundary conditions.

If we focus on a single term, that is, we set  $\mu$  and choose an end. Let  $\sigma_*$  be the coordinate  $\sigma$  of an end;  $\sigma_*$  can be zero or equal to  $\sigma_1$ .

As before, there are two natural boundary conditions that can be imposed on an endpoint.

The first is a boundary condition of Dirichlet, in which the end of the string remains fixed throughout the movement:

Dirichlet boundary condition:

$$\frac{\partial X^\mu}{\partial \tau}(\tau, \sigma_*) = 0. \quad \mu \neq 0 \quad (5.55)$$

As the time varies with  $\tau$  (see (5.29)), the value  $\mu = 0$  must be excluded. Since the constant in  $\tau$  means the constant in time, the equation (5.55) implies that the  $\mu$  coordinate of the end of the selected string is fixed in time.

We can specify a constant value for  $X^\mu(\tau, \sigma_*)$ . If the end of the string is fixed, the variations are defined to disappear there  $\partial X^\mu(\tau, \sigma_*)$ .

The second possible limit condition is a free endpoint condition

$$P_\mu^\sigma(\tau, \sigma_*) = 0 \quad (5.56)$$

This condition, if necessary, also results in the disappearance of the relevant term in (5.5). This is called a free endpoint condition because it imposes no constraint on the variation  $\partial X^\mu(\tau, \sigma_*)$  of the string coordinate at the end is free to do whatever is necessary to make disappear the variation of the action. The limit condition of the free end must apply for  $\mu = 0$ .

$$P_0^\sigma(\tau, \sigma_1) = P_0^\sigma(\tau, 0) = 0 \quad (5.57)$$

For the non-relativistic chain, the boundary condition of the free end implies the disappearance of  $P^x$ , which imposes a boundary condition of Neumann on the coordinate of the string.

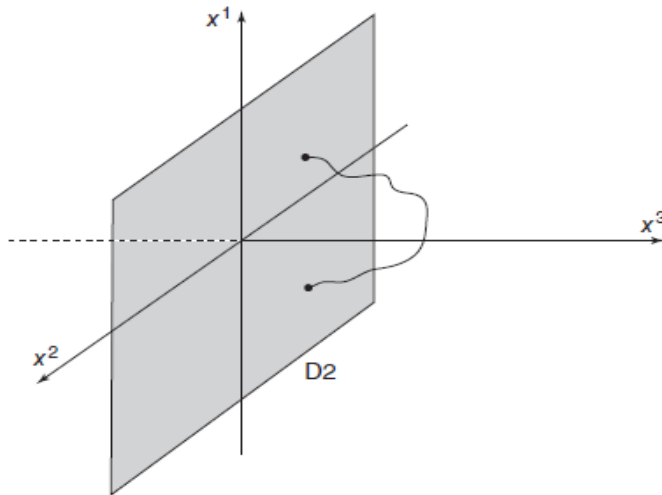

**Fig5-7 A brane D2- stretched on the plane  $(X^1, X^2)$ . The end of the open string can move freely on the plane but must remain attached to it. The  $x^3$  coordinate of the ends must disappear at any time. This is a boundary condition of Dirichlet for the string coordinate  $x^3$ .**

We end up understanding (5.56) in terms of a boundary condition of Neumann. Similarly, the Dirichlet limit (5.55) will be involved in the disappearance of  $P_\mu^t$  ends of the string.

To explain the case of the boundary conditions of Dirichlet. It is clear from the non-relativistic string study that the boundary conditions of Dirichlet occur if the ends of the strings are attached to certain physical objects. For example, consider the following figure;

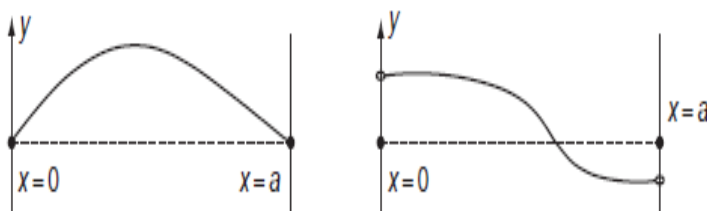

**Fig. 5-8 Left: strings with boundary conditions of Dirichlet at the ends. Right: string with Neumann boundary conditions at the ends**

On the left, the string is attached to two points on the right, the rope is free to slide up and down at the ends; the ends of the strings are forced to remain on one-dimensional lines and the horizontal movement of the ends is forbidden.

The objects on which the ends of the open strings must bear are characterized by their dimensionality, more precisely by the number of spatial dimensions they possess. They are called D-branes, where the letter D means Dirichlet. The objects that fix the ends of the strings on the left side of figure 4.2 are of dimension zero. They are called D0-branes. The lines that bind the ends of the strings on the right side of the figure are one dimension. They are called D1-branes.

$AD_p$ -brane is an object with spatial dimensions. Since string endpoints must be on point  $D_p$  a Dirichlet boundary condition set is specified. A second plane  $D_2$  in a three-dimensional space, for example, is specified by a condition. Say  $x^3 = 0$  (Figure 5.7). This means that the brane  $D_2$  expands on the plane  $(x^1, x^2)$ . The Dirichlet limit condition applies to the string coordinate  $X^3$ , which must disappear at the ends of the string. Since the movement of the ends of the open strings is free in the direction of the brane, the coordinates of the strings  $X^1$  and  $X^2$  satisfy the free boundary conditions. When open-ended endpoints have free-bound conditions in all directions of space, we still have a D-brane, but this time it's a D-brane filling the space. The D-brane extends over the entire space, and since the open string ends may be anywhere on the D-brane, the open string ends are completely free. For relativistic (quantum) strings, the coherence of the boundary conditions of Dirichlet makes it possible to discover the properties of D-brane. Are physical objects existing in a string theory and are not introduced by hand. D-branes have computable energy densities and a host of remarkable properties.

## 5-6 the static gauge

To progress in understanding the action of the relativistic string, it is very useful to set the world map. The choice of the parameterization was done freely because of the invariance of reparametrisation of the action of string. Invariance by reparamétrisation in the theory of the strings is analogous to the invariance of the gauges in electrodynamics. Maxwell's equations have a symmetry under Gauge transformations that allows to use different potentials  $A_\mu$  to represent the same electromagnetic fields  $\vec{E}$  and  $\vec{B}$ . In the same way one can use many different grids on the sheet of the world to describe the same physical movement of the rope. An appropriate choice of the grid facilitates this task. The equation of motion of the relativistic particle is simpler when the trajectory is parameterized by the proper time.

In this section we will discuss only partial setting on the world sheet. We will fix the lines of the constant  $\tau$  en relating  $\tau$  to the time coordinate  $X^0 = cst$  in a chosen Lorentz plot. The constant time hyper plane  $t = t_0$  is considered in the target space (Figure 5.8). This plane intersects the world sheet along a curve. The string at time  $t_0$ , and the curve is a curve of constant  $\tau$ ; in fact, one declares at the curve  $\tau = t_0$ , and that for every point Q on the sheet of the world.

$$\tau(Q) = t(Q) \tag{5.58}$$

This  $\tau$  parameterization is called static gauge because the constant lines  $\tau$  are "static strings" in the chosen Lorentz frame.

For an open string, one edge of the world leaf will be chosen as the curve  $\sigma = 0$  and the other as the curve  $\sigma = \sigma_1$ . The world leaf is the surface  $\sigma \in [0, \sigma_1]$ , for an open string (5.59).

We will draw lines of constants  $\sigma$  on the surface in a completely arbitrary way, provided, of course, that the constant lines  $\sigma$  vary smoothly do not intersect and are in agreement with the two curves which are the boundary of the leaf of the world (Figure 5.8).

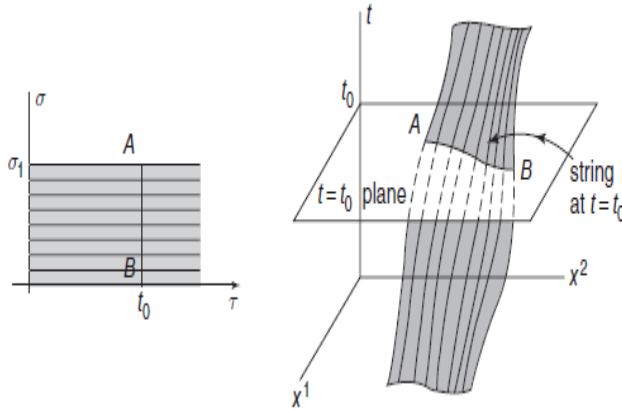

**Figure 5-9. Left: the parameter space band for an open string. The vertical segment AB is the line  $\tau = t_0$ . Right: the world map of the string open in the target space. The string at time  $t = t_0$  is the intersection of the world leaf with the hyper plane  $t = t_0$ . In the static gauge, the string at time  $t = t_0$  is the image of  $\tau = t_0$  segment AB.**

To draw lines of constant  $\sigma$  is equivalent to giving an explicit parameterization  $\sigma$  to all the strings. For the closed strings, one applies the same ideas, but there is an important condition: there must be identification in the space of the parameters  $(\tau, \sigma)$ . The direction  $\sigma$  must be transformed into a circle, which makes the parameter space  $(\tau, \sigma)$  in a cylinder. This is necessary because the closed-string world map is logically a cylinder.  $\sigma_c$  Indicates the circumference of the circle  $\sigma$ , the identification is

$$(\tau, \sigma) \sim (\tau, \sigma + \sigma_c) \quad (5.60)$$

The points that are identified by this relationship on the parameter space map at the same point on the closed chain world map. Closed strings can be parameterized using any interval of length  $\sigma$ , for example

$$\sigma \in [0, \sigma_c]. \text{ For a closed string} \quad (5.61)$$

We will now see some implications of our choice of  $\tau$ . We can write (5.58) as

$$X^0(\tau, \sigma) \equiv ct(\tau, \sigma) = c\tau \quad (5.62)$$

Or simply

$$\tau = t \quad (5.63)$$

We can therefore describe the collection of string coordinates  $X^\mu$  as

$$X^\mu(\tau, \sigma) = X^\mu(t, \sigma) \{ct, \vec{X}(t, \sigma)\} \quad (5.64)$$

$\vec{X}$  Represent the coordinates of the space string.

$$\frac{\partial X^\mu}{\partial \sigma} = \left( \frac{\partial X^0}{\partial \sigma}, \frac{\partial \vec{X}}{\partial \sigma} \right) = \left( 0, \frac{\partial \vec{X}}{\partial \sigma} \right).$$

$$\frac{\partial X^\mu}{\partial \tau} = \left( \frac{\partial X^0}{\partial t}, \frac{\partial \vec{X}}{\partial t} \right) = \left( 0, \frac{\partial \vec{X}}{\partial t} \right) \quad (5.65)$$

Note that this setting separates the time and space components in a very clear way.

Now we can do a simple test to confirm that we got the right sign under the radical in the Nambu-Goto action (5.39).

Imagine a small piece of string without velocity. Because it does not move,  $\frac{\partial \vec{X}}{\partial t} = 0$  and using (5.65), the square root in (5.39) becomes

$$\sqrt{0 - \frac{\partial \vec{X}^2}{\partial \sigma} (-c^2)} \quad (5.66)$$

The quantity under the square root is positive, as expected

## 5-7 Tension and energy of a tense rope

We now do our first calculation with the Nam-Goto action, our first calculation in string theory.

Our analysis on a stretched relativistic string.

The ends of the string are set to  $x^1 = 0$  and  $x^1 = a > 0$  with null values for the coordinates of the additional spatial dimensions. We therefore designate the spatial coordinates of the extremities as  $(0, \vec{0})$  and  $(a, \vec{0})$ . The inclusion of the common vector  $(d, -1)$ -dimensional  $\vec{0}$  tells us that the string is only stretched along the first spatial coordinate. The action of the string for this stretched string is evaluated using the static gauge  $X^0 = c\tau$ .

Because it is a static string stretched from  $X^1 = 0$  to  $X^1 = a$ , we can write

$$X^1(t, \sigma) = f(\sigma), X^2 = X^3 = \dots = X^d = 0 \quad (5.67)$$

Where

$$f(0) = 0, f(\sigma_1) = a \quad (5.68)$$

And the function  $f$  is strictly increasing and continuous over the interval  $\sigma \in [0, \sigma_1]$ . The configuration is shown in Figure (6.9). It is guaranteed that each string point is assigned a unique  $\sigma$  coordinate.

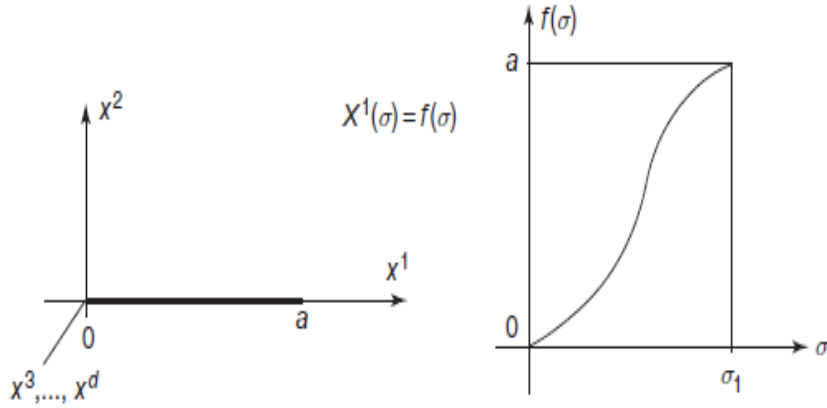

**Fig.5-10.**A string of length stretched along the axis  $X^1$ . The string is parametrized as  $X^1(t, \sigma) = f(\sigma)$ .

It now follows.

$$\dot{X}^\mu = (c, 0, \vec{0}), \dot{X}^\mu = (0, f', \vec{0}), \quad (5.69)$$

With  $f' = df/d\sigma > 0$

$$\dot{X}^2 = -c^2, (X')^2 = (f')^2, \dot{X}X' = 0 \quad (5.70)$$

We can now evaluate the action (6.39):

$$S = -\frac{T_0}{c} \int_{t_i}^{t_f} dt \int_0^{\sigma_1} d\sigma \sqrt{0 - (-c^2)(f')^2} = -T_0 \int_{t_i}^{t_f} dt \int_0^{\sigma_1} d\sigma \frac{df}{d\sigma} \quad (5.71)$$

The integrator  $\sigma$  is a total derivative, so

$$S = -T_0 \int_{t_i}^{t_f} dt (f(\sigma_1) - f(0)) = \int_{t_i}^{t_f} dt (-T_0 a) \quad (5.72)$$

This is an explicit confirmation of the reparameterization invariance of the string action.

Reminder: the action is the temporal integral of Lagrangian  $L$ . When the kinetic energy disappears,  $L = -V$ , where  $V$  is the potential energy. Since our string is static, there is no kinetic energy, so

$$S = \int_{t_i}^{t_f} dt (-V) \quad (5.73)$$

Comparing this with (6.72) we conclude that

$$V = T_0 a \quad (5.74)$$

The potential energy of our tight rope is just  $T_0 a$ .

So if the voltage of a static string is  $T_0$ , whatever its length,  $T_0 a$  is the amount of energy that must be spent to create a string of length  $a$ .

If we begin to draw an infinitesimal string, we give energy to the rope; in fact we create rest or mass energy at rest. The remaining mass  $\mu_0$  per unit length is

$$\mu_0 c^2 = \frac{V}{a} = T_0 \quad \rightarrow \quad \mu_0 = \frac{T_0}{c^2} \quad (5.75)$$

The mass (or energy of rest) arise only because the rope has a tension. For this reason, the relativistic string is sometimes referred to as mishmash.

Because of (5.69),  $ni\dot{X}^\mu niX^{\mu'}$  have no dependence. Therefore, neither  $niP^\tau niP^\sigma$  is dependent (see (5.49) and (5.50)), which is the case, the equation of motion (5.53) is reduced to

$$\frac{\partial P_\mu^\sigma}{\partial \sigma} = 0 \quad (5.76)$$

This requires that  $P_\mu^\sigma$  be independent of  $\sigma$ . We still look at (5.50) and we use (5.70) to find

$$P_\mu^\sigma = -\frac{T_0}{c} \frac{c^2 X'_{\mu}}{\sqrt{c^2 (f')^2}} = -T_0 \frac{X'_{\mu}}{f'} \quad (5.77)$$

This c is not zero only for  $\mu = 1$  in which case  $X'_1 = f'$ , so  $P^\sigma$  is indeed independent of  $\sigma$ . So the equation of motion is satisfied. Even the boundary conditions are satisfied. For the zero coordinate, the equation (5.57) requires the free boundary condition  $P_0^\sigma = 0$ . This goes for (5.77).

## 5-8 Action in terms of transverse speed

The choice of the partial parameterization of the sheet of the world which has been made imposes the condition  $X^0 = ct = c\tau$ .

Then the constant line  $\tau$  on the sheet of the world corresponds to the string, as seen by the observer of Lorentz chosen at the time, at the particular time  $t = \tau$ .

What kind of rope velocity can we define?

Since the components of  $\vec{X}(t, \sigma)$  are spatial coordinates of the string, the derivative  $\partial\vec{X}/\partial t$  seems to be the closest thing to velocity. This speed, however, depends on the choice of  $\sigma$ . Its direction, for example, goes in the direction of constants  $\sigma$ .

The physical setting of the parameterization  $\sigma$  of a string is subtle because the string is an object without substructure. To talk about points on the string one needs a parameterization, and the invariance of reparamétrisation makes it possible to understand that this parameterization is not unique. This suggests that the longitudinal movement of the rope has no physical meaning. There is an invariant reparamétrisation speed which can be defined on the string. It is however a transverse speed.



### Interpretation of Figure (5.10):

We consider the movement of the rope in space; imagine that each point of the rope moves transversely to the rope. Consider a string at a certain time  $t$  and choose a point above. Draw the orthogonal hyperplane to the string on  $p$ . At time  $t + dt$ , with infinitesimal, the string has moved, but it will always intersect the plane, this time at a point  $p'$ . The transverse velocity is what we obtain if we suppose that the point  $p$  has moved towards  $p'$ . No channel parameterization is needed to set this velocity.

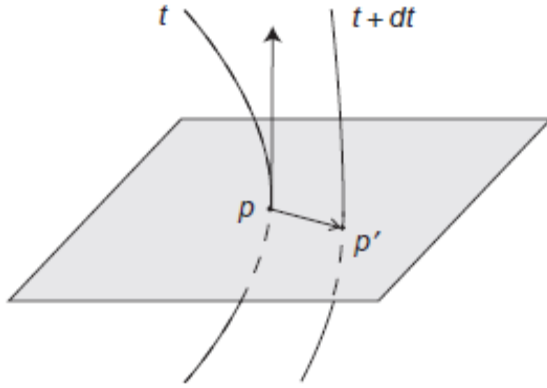

**Figure 5-11** A string at time  $t$  and the point orthogonal to the string at  $p$ . At the instant  $+dt$ , the string cuts the plane in  $p'$ . To define the transverse velocity, we assume that  $p$  has passed to  $p'$ .

The transverse velocity  $\vec{v}_\perp$  at any point of the string is a vector orthogonal to the string and tangent to the spatial surface of the string. Since  $\vec{v}_\perp$  is an invariant notion of speed of reparametrisation of the string, it is expected that it naturally enters into the evaluation of the action of the string.

To define the transversal velocity  $\vec{v}_\perp$ , it is useful to have a unit vector tangent to the string. Finally we now introduce a parameter  $s$  which is more physical than our almost arbitrary  $\sigma$ :  $s$  measures the length along the string.

We define  $s(\sigma)$  as the length of the string in the interval  $[0, \sigma]$ . For example,  $s(0) = 0$ , and  $s(\sigma_1)$  is the length of an entire open string. Since  $ds$  is the length of the infinitesimal vector  $d\vec{X}$  that comes from an interval  $d\sigma$  along the string, we have:

$$ds = |d\vec{X}| = \left| \frac{\partial \vec{X}}{\partial \sigma} \right| |d\sigma| \quad (5.78)$$

We now consider the quantity  $\partial \vec{X} / \partial s$ , which is the rate of change of  $\vec{X}$  with respect to the length of the chain. Note that it is a unit vector:

$$\frac{\partial \vec{X}}{\partial s} \cdot \frac{\partial \vec{X}}{\partial s} = \frac{\partial \vec{X}}{\partial \sigma} \cdot \frac{\partial \vec{X}}{\partial \sigma} \left( \frac{\partial \sigma}{\partial s} \right)^2 = \left( \frac{\partial \vec{X}}{\partial \sigma} \right)^2 \left( \frac{\partial \sigma}{\partial s} \right)^2 = 1 \quad (5.79)$$

The derivative  $(\partial \vec{X} / \partial \sigma) / \partial \sigma$  is taken with  $t$  held fixed, so that it lies along a constant line. Since the lines of the constant  $t$ . Are precisely the strings, they are tangents to the rope. In addition

$$\frac{\partial \vec{X}}{\partial s} = \frac{\partial \vec{X}}{\partial \sigma} \frac{\partial \sigma}{\partial s} \quad (5.80)$$

And so  $\frac{\partial \vec{X}}{\partial s}$  is also tangent to the string. Because he has the length of the unit.

$\frac{\partial \vec{X}}{\partial s}$  is a unit vector tangent to the string (5.81)

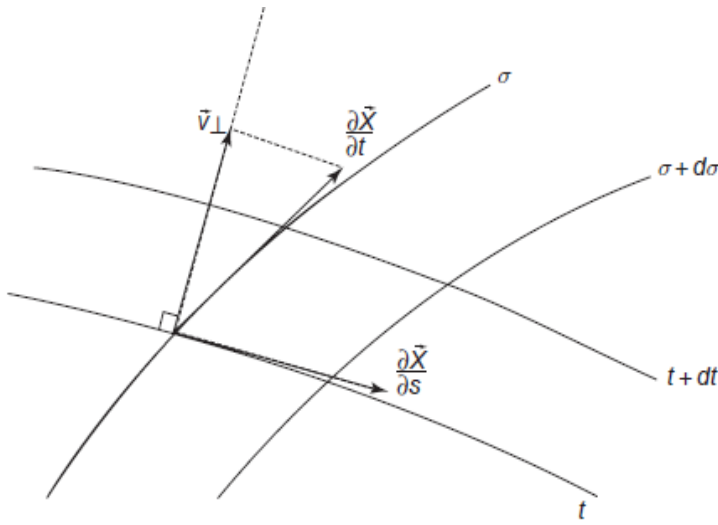

**Fig5-12** a small piece of the world leaf showing the vector  $\frac{\partial \vec{X}}{\partial t}$ , the transverse velocity  $\vec{v}_\perp$  and the unit vector  $\frac{\partial \vec{X}}{\partial s}$ .

$\vec{v}_\perp$  is taken as the component of the velocity  $\frac{\partial \vec{X}}{\partial t}$ , in the direction perpendicular to the string (see figure5 .11). Using our unit vector  $\frac{\partial \vec{X}}{\partial s}$  along the string, we have

$$\vec{v}_\perp = \frac{\partial \vec{X}}{\partial t} - \left( \frac{\partial \vec{X}}{\partial t} \cdot \frac{\partial \vec{X}}{\partial s} \right) \frac{\partial \vec{X}}{\partial s} \quad (5.82)$$

The calculation of  $v_\perp^2$  gives:

$$v_\perp^2 = \left( \frac{\partial \vec{X}}{\partial t} \right)^2 - \left( \frac{\partial \vec{X}}{\partial t} \cdot \frac{\partial \vec{X}}{\partial s} \right)^2 \quad (5.83)$$

Now, our goal is to write the chord action in terms of  $\vec{v}_\perp$  and other quantities, if necessary. Using the static gauge  $\tau = t$ , and the equations (5.65), we find

$$(\dot{X})^2 = -c^2 + \left( \frac{\partial \vec{X}}{\partial t} \right)^2, \quad (X')^2 = \left( \frac{\partial \vec{X}}{\partial \sigma} \right)^2, \quad \dot{X}X' = \frac{\partial \vec{X}}{\partial t} \cdot \frac{\partial \vec{X}}{\partial \sigma} \quad (5.84)$$

With these relationships, we simplify the argument of the square root in the string

$$\begin{aligned} \text{action: } (\dot{X} \cdot X')^2 - (\dot{X})^2 (X')^2 &= \left( \frac{\partial \vec{X}}{\partial t} \cdot \frac{\partial \vec{X}}{\partial \sigma} \right)^2 + \left[ c^2 - \left( \frac{\partial \vec{X}}{\partial t} \right)^2 \right] \left( \frac{\partial \vec{X}}{\partial \sigma} \right)^2 = \\ &= \left( \frac{\partial s}{\partial \sigma} \right)^2 \left[ \left( \frac{\partial \vec{X}}{\partial t} \cdot \frac{\partial \vec{X}}{\partial s} \right)^2 + c^2 - \left( \frac{\partial \vec{X}}{\partial t} \right)^2 \right] \end{aligned} \quad (5.85)$$

The terms on the right side above can be perfectly expressed in terms of  $v_\perp^2$ . Using (5.83).

$$(\dot{X} \cdot X')^2 - (\dot{X})^2 (X')^2 = \left( \frac{\partial s}{\partial \sigma} \right)^2 (c^2 - v_\perp^2) \quad (5.86)$$

Or

$$\sqrt{(\dot{X} \cdot X')^2 - (\dot{X})^2 (X')^2} = c \frac{\partial s}{\partial \sigma} \sqrt{1 - \frac{v_{\perp}^2}{c^2}} \quad (5.87)$$

This simple expression for the Lagrangian string shows that  $\vec{v}$  is a natural dynamic variable. Moreover the longitudinal component of the speed is completely out of rest. Now we can write the string action as

$$S = -T_0 \int dt \int_0^{\sigma_1} d\sigma \left( \frac{ds}{d\sigma} \right) \sqrt{1 - \frac{v_{\perp}^2}{c^2}} \quad (5.88)$$

Here  $\frac{ds}{d\sigma} = |\partial \vec{X} / \partial \sigma|$ .  $d\sigma$  is not cancelled because it is useful to have an integral over a fixed parameter range. So the range of  $\sigma$  is constant. We introduce  $s$  as the function of  $\sigma$  which gives the length of the string at a fixed time. This definition, used at different times, confers a temporal dependence that can be relevant if we compare strings at different times.

The associated Lagrangian is given by

$$L = -T_0 \int ds \sqrt{1 - v_{\perp}^2} \quad (5.89)$$

Expression (6.89) is like the natural generalization of the Lagrangian relativistic particle (5.8). Action (6.88) is valid for both open strings.

Although relatively simple, it leads to rather complicated equations of motion in all but the most symmetrical situations.

We end this section by simplifying the expressions (5.49) and (5.50) for  $P^{\tau\mu}$  and  $P^{\sigma\mu}$  in the static gauge.

For  $P^{\sigma\mu}$ . Its denominator is given in (5.87) and its numerator is simplified using relations (5.84). We find

$$P^{\sigma\mu} = -\frac{T_0}{c} \frac{\left( \frac{\partial \vec{X}}{\partial \sigma} \cdot \frac{\partial \vec{X}}{\partial t} \right) X'^{\mu} - \left( -c^2 + \left( \frac{\partial \vec{X}}{\partial t} \right)^2 \right) X^{\mu}}{c \frac{ds}{d\sigma} \sqrt{1 - v_{\perp}^2}} \quad (5.90)$$

By rising the  $ds/d\sigma$  of the denominator to the numerator, we can transform the derivatives with respect to  $\sigma$  en derivatives with respect to  $s$ .

$$P^{\sigma\mu} = -\frac{T_0}{c^2} \frac{\left( \frac{\partial \vec{X}}{\partial s} \cdot \frac{\partial \vec{X}}{\partial t} \right) X'^{\mu} + \left( c^2 - \left( \frac{\partial \vec{X}}{\partial t} \right)^2 \right) \frac{\partial X^{\mu}}{\partial s}}{\sqrt{1 - \frac{v_{\perp}^2}{c^2}}} \quad (5.91)$$

The component  $\mu = 0$  of this quantity simplifies considerably. Since  $X^0 = ct$  and  $\frac{\partial X^0}{\partial s} = c \frac{\partial t}{\partial s} = 0$ .

We find

$$P^{\sigma 0} = -\frac{T_0}{c} \frac{\left(\frac{\partial \bar{X}}{\partial s} \frac{\partial \bar{X}}{\partial t}\right)}{\sqrt{1 - \frac{v_1^2}{c^2}}} \quad (5.92)$$

A rather similar calculation for  $P^{\tau\mu}$  gives

$$P^{\tau\mu} = \frac{T_0}{c^2} \frac{ds}{d\sigma} \frac{X^\mu - \left(\frac{\partial \bar{X}}{\partial s} \frac{\partial \bar{X}}{\partial t}\right) \frac{\partial X^\mu}{\partial s}}{\sqrt{1 - \frac{v_1^2}{c^2}}} \quad (5.93)$$

# Chapter 06

## D-branes

<<The most important single thing about string theory is that it's a highly mathematical theory , and the mathematics holds together in a very tight and consistent way . It contains in its basic structure both quantum mechanics and the theory of gravity. That's big news >>[1]

*Leonard Susskind*

### Introduction

So far we have studied the open strings that have been described by coordinates that satisfy all the boundary conditions of Neumann. These open strings open on the volume of world of a D25-brane filling the space. Here we quantify the open strings attached to  $D$ -branes more general. We start with the case of a single  $D_p$ -brane, with  $1 \leq p \leq 25$  then we go on to the case of several parallel  $D_p$ -branes where the interactive gauge fields appear and the possibility of massive gauge fields. We continue with the case of parallel  $D$ -branes of different dimensions.

### 6-1 $D_p$ -branes and boundary conditions

A  $D_p$ -brane is an extended object with  $p$  spatial dimensions. In the theory of bosonic strings where the number of spatial dimension is 25, a brane D25 is a brane filling the space. The letter D in  $D_p$ -brane represents Dirichlet. From a  $D_p$ -brane, the ends of the open string must be on the brane. As will be discussed in more detail below, this requirement imposes a number of Dirichlet boundary conditions on the movement of the ends of open strings.

All the extended objects that teach the theory are not D-branes. The strings for example, are 1-branes because they are extended objects with a spatial dimension, but they are not branes D1. Branes with  $p$  spatial dimensions are usually called  $p$ -branes. A 0-brane is a kind of particle. Just as the world line of a particle is one-dimensional, the world volume of a  $p$ -brane is  $(p + 1)$  dimensional. Among these dimensions  $p + 1$ , one is the temporal dimension and the other  $p$  are spatial dimensions. First we will discuss the concept of D-branes in section (5.5). In addition the problem (5.11) considered the classical movement of the open strings ending with D-branes of various dimensions.

Our main subject in this chapter is the quantification of open strings in the presence of various types of D-branes. It is a rich subject with important implications for the problem of building realistic physical models using strings. Moreover, the study of D-branes and the gravitational fields they produce has led to surprising new discoveries in the study of strong interaction gauge theories.

In this section, the notation required to describe D-brane is put in place and the appropriate boundary conditions are stated. We denote  $d$  the total number of spatial dimensions in the theory: in this case  $d = 25$ . The total number of space-time dimensions is  $D = d + 1 = 26$ . A  $D_p$ -brane with  $p < 25$  extends over a  $p$ -dimensional subspace of the 25-dimensional space. We will focus on the simple  $D_p$ -branes: the ones that are  $p$ -dimensional, hyperplanes inside the dimension space  $D$ .

How can one specify such hyper planes?

We need  $(d-p)$  linear conditions. In three spatial dimensions ( $d = 3$ ), a 2-brane ( $p = 2$ ) is a plane and is specified by a linear condition ( $d-p = 3-2 = 1$ ). For example,  $z = 0$  specifies the plane  $(x, y)$ . Similarly, a string along the  $z$  axis ( $p = 1$ ) is specified by two linear conditions ( $d-p = 3-1 = 2$ ):  $x = 0$  et  $y = 0$ .

Now consider a  $D_p$ -brane. We introduce the space-time coordinates  $x^\mu$  with  $\mu = 0, 1, \dots, 25$  which are divided into two groups. The first group includes tangential coordinates to the volume world of the brane. These are the temporal coordinates and the spatial coordinate's  $p$ . The second group includes the coordinates  $(d-p)$  normal to the volume-world of the brane. We write

$$\underbrace{x^0, x^1, \dots, x^p}_{Dp\text{coordonn } \acute{e}estangentielle} \quad \underbrace{x^{p+1}, x^{p+2}, \dots, x^d}_{Dp\text{coordonn } \acute{e}esnormales} \quad (6.1)$$

The location of the  $D_p$ -brane is specified by setting the values of the normal coordinates to the brane. With this division in mind, we write

$$x^a = \bar{x}^a, \quad a = p + 1 \dots \dots \dots d \quad (6.2)$$

Here the  $\bar{x}^a$  are a set of constraints  $(d-p)$ . In a completely analogous way the choral coordinates  $X^\mu(\tau, \sigma)$  are split as

$$\underbrace{X^0, X^1, \dots, X^p}_{Dp\text{coordonn } \acute{e}estangentilles} \quad \underbrace{X^{p+1}, X^{p+2}, \dots, X^d}_{Dp\text{coordonn } \acute{e}esnormales}$$

Since the ends of the open chain must be on the  $D_p$  ramp, the normal coordinates of the brane must meet the Dirichlet boundary conditions.

Since the ends of the open chain must be on the  $D_p$  ramp, the normal coordinates of the brane must meet the Dirichlet boundary condition

$$X^{m'}(\tau, \sigma)|_{\sigma=0} = X^{m'}(\tau, \sigma)|_{\sigma=\pi} = 0 \quad m = 0, 1, \dots, p \quad (6.5)$$

These string coordinates are called NN coordinates because both ends satisfy a boundary condition of Neumann. We see that the division (6.3) in tangential and normal coordinates

and also a division in coordinates that satisfy the boundary conditions of Neumann and Dirichlet, respectively

$$\underbrace{X^0, X^1, \dots, \dots, X^p}_{NN\text{coordinates}} \underbrace{X^{p+1}, X^{p+2}, \dots, \dots, X^d}_{DD\text{coordinates}} \quad (6.6)$$

In order to use the light cone gauge, at least one spatial NN coordinate is needed which can be used with  $X^0$  to define the coordinates  $X^\pm$ . We must assume  $p \geq 1$ . To study them, we need a Lorentz covariant quantification. We will label the coordinates of the light-cone as

$$\underbrace{X^+, X^-, \{X^i\}}_{NN} \underbrace{\{X^a\}}_{DD} \quad i = 2 \dots p \quad a = p + 1 \dots \dots d \quad (6.7)$$

## 6-2 Quantification of open strings on $D_p$ -branes

The procedure of quantizing open strings in the presence of a  $D_p$ -brane, allows us to make an analysis to determine the spectrum of the states of open strings and to use this result to understand more deeply what happens on the volume. The coordinates NN  $X^i(\tau, \sigma)$  satisfy exactly the same conditions which are satisfied by the coordinates  $X^I(\tau, \sigma)$  of the cone of light of the open chains attached to a brane D25. . All the expansions and commutations relations for the  $X^i$  coordinates can be obtained from  $X^I$  by replacing  $I \rightarrow i$  in the relevant equations.

Recall :

$$\dot{X}^- \pm X^{-'} = \frac{1}{2\alpha'} \frac{1}{2p^+} (\dot{X}^I \pm X^{I'})^2 \quad (6.8)$$

Moreover, the expansion of  $\dot{X}^I \pm X^{I'}$  is:

$$\dot{X}^I \pm X^{I'} = \sqrt{2\alpha'} \sum_{n \in \mathbb{Z}} \alpha_n^I e^{-in(\tau \pm \sigma)} \quad (6.9)$$

A completely analogous mode expansion maintained for the  $X^-$  coordinate; this expansion continues to hold unchanged since  $X^-$  remains an NN coordinate. We summarize as

$$2p^+ p^- \equiv \frac{1}{\alpha'} \left( \frac{1}{2} \alpha'_0 \alpha_0' + \sum_{n=1}^{\infty} \alpha'_{-n} \alpha_n' + a \right) \quad (6.10)$$

The order constant  $a$  has been determined to be at least one for the quantization of strings on a D25 brane. The cone of light index  $I = 2 \dots \dots \dots, 25$ , takes values which, for a ramp  $D_p$ , are executed on the coordinates  $i$  and DD indicated by a. Consequently. (6.8) now become

$$\dot{X}^- \pm X^{-'} = \frac{1}{2\alpha'} \frac{1}{2p^+} \left\{ (\dot{X}^i \pm X^{i'})^2 + (\dot{X}^a \pm X^{a'})^2 \right\} \quad (6.11)$$

Like, the coordinates are extended.

$$\dot{X}^i \pm X^{i'} = \sqrt{2\alpha'} \sum_{n \in \mathbb{Z}} \alpha_n^i e^{-in(\tau \pm \sigma)} \quad (6.12)$$

The coordinates  $X^a$  are those to be studied.

Now, the second part of the quantification of open strings attached to a  $D_p$ -brane is discussed.

The brane normal  $X^a$  coordinates satisfy the wave equation, so that the general solution is a superposition of two waves

$$X^a(\tau, \sigma) = \frac{1}{2}(f^a(\tau + \sigma) + g^a(\tau - \sigma)). \quad (6.13)$$

Examining the boundary conditions (15.4). At  $\sigma = 0$  we get

$$X^a(\tau, 0) = \frac{1}{2}(f^a(\tau) + g^a(\tau)) = \bar{x}^a \quad (6.14)$$

So that

$$g^a(\tau) = f^a(\tau) + 2\bar{x}^a \quad \text{And therefore,}$$

$$X^a(\tau, \sigma) = \bar{x}^a + \frac{1}{2}(f^a(\tau + \sigma) - f^a(\tau - \sigma)) \quad (6.15)$$

The limiting condition at  $\sigma = \pi$  then gives us

$$f^a(\tau + \pi) = f^a(\tau - \pi) \quad (6.16)$$

This means that  $f^a(u)$  is a periodic function with the period  $2\pi$ .

This information is incorporated in the following extension:

$$f^a(u) = \tilde{f}_0^a + \sum_{n=1}^{\infty} (\tilde{f}_n^a \cos nu + \tilde{g}_n^a \sin nu) \quad (6.17)$$

It is interesting to note that there is no linear term in  $u$ . Such a term was present when the legend fulfilled a boundary condition of Neumann because, in this case, it was the derivative  $f'(u)$  which was periodic. Replace (6.17) in (6.15) and perform some trigonometric simplification: we find

$$X^a(\tau, \sigma) = \bar{x}^a + \sum_{n=1}^{\infty} (-\tilde{f}_n^a \sin n\tau \sin n\sigma + \tilde{g}_n^a \cos n\tau \sin n\sigma). \quad (6.18)$$

Redefining the expansion coefficients that are arbitrary anyway, we can write

$$X^a(\tau, \sigma) = \bar{x}^a + \sum_{n=1}^{\infty} (\tilde{f}_n^a \cos n\tau + \tilde{f}_n^a \sin n\tau) \sin n\sigma. \quad (6.19)$$

Since there is no linear term in  $\tau$ . The string has no average time in the  $x$  direction. This is reasonable since the strings must remain attached to the brane. If there were a term  $p^a \tau$  present, the ends  $\sigma = 0, \pi$  would not remain at  $x^a = \bar{x}^a$  when  $\tau \neq 0$ .

In order to define the quantum theory associated with  $X^a$ , we are interested in the classical parameters that describe the motion of the open string in equation 6.19).

On the one hand, the values  $\bar{x}^a$  are not parameters that can be added to describe various movements the other hand the  $(f^a, \tilde{f}^a)$  are parameters of the open string motion. So, by quantifying the open string, the  $\bar{x}^a$  remain numbers and do not become operators, while the  $(f^a, \tilde{f}^a)$  become operators.

We rewrite (6.19) in terms of defined oscillators in order to simplify the following analysis:



$$\text{of open chains, on } X^a(\tau, \sigma) = \bar{x}^a + \sqrt{2\alpha'} \sum_{n \neq 0} \frac{1}{n} \alpha_n^a e^{-in\tau} \sin n\sigma \quad (6.20)$$

The coordinate of the chord  $X^a$  is Hermitian if

$$(\alpha_n^a)^\dagger = \alpha_{-n}^a, \quad \text{which is the usual property}$$

Hermiticity of the oscillator. Note that the zero modes  $\alpha_0^a$  did not exist. Additionally

$$\dot{X}^a = -i\sqrt{2\alpha'} \sum_{n \neq 0} \alpha_n^a e^{-in\tau} \sin n\sigma. \quad X^{a'} = \sqrt{2\alpha'} \sum_{n \neq 0} \alpha_n^a e^{-in\tau} \cos n\sigma \quad (6.21)$$

And so

$$X^{a'} \pm \dot{X}^a = \sqrt{2\alpha'} \sum_{n \neq 0} \alpha_n^a e^{-in(\tau \pm \sigma)} \quad (6.22)$$

The analogy with (6.12) is quite close, but there are two differences.

The first, when the lower sign applies, the derivative combinations differ by a global negative sign. Second, the zero modes are absent from (6.22).

Quantization is now right; with

$P^{\tau a}(\tau, \sigma) = \dot{X}^a/2\pi\alpha$ . It is assumed that the non-invisible switches are

$$[X^a(\tau, \sigma), \dot{X}^b(\tau, \sigma')] = 2\pi\alpha' i \delta^{ab} \delta(\sigma - \sigma') \quad (6.23)$$

Since the mode expansions (6.22) take the standard form, the difference of overflow sign mentioned below is irrelevant since  $(X^{a'} - \dot{X}^a)$  appears twice in the relevant switches. So we find

$$[\alpha_m^a, \alpha_n^b] = m\delta^{ab} \delta_{m+n,0}, \quad m, n \neq 0 \quad (6.24)$$

The zero modes operate uniformly:  $\bar{x}^a$  is a constant, and there is no conjugate quantity since  $\alpha_0^a \equiv 0$ . The sign difference is also irrelevant for the evaluation of (6.11) since  $(X^{a'} - \dot{X}^a)$  appears squared. Therefore, equation (6.10) can be divided into (6.25)

$$2p^+ p^- \equiv \frac{1}{\alpha'} (\alpha' p^i p^i + \sum_{n=1}^{\infty} [\alpha_{-n}^i \alpha_n^i + \alpha_{-n}^a \alpha_n^a] - 1) \quad (6.25)$$

Since  $p^a \sim \alpha_0^a \equiv 0$  and  $\alpha_0^\mu = \sqrt{2\alpha} p^\mu$ . The control constant was set at minus one, as for the D25-brane. The critical dimension has not been modified either. In particular, the naive contributions necessary for the normal order  $L_0^\perp$  are the same for  $X^a$  and  $X'$ . It follows from (6.25) that (6.26)

$$M^2 = -p^2 = 2p^+ p^- - p^i p^i = \frac{1}{\alpha'} (\sum_{n=1}^{\infty} [\alpha_{-n}^i \alpha_n^i + \alpha_{-n}^a \alpha_n^a] - 1). \quad (6.26)$$

Using creation and annihilation operators we obtain (6.27)

$$M^2 = \frac{1}{\alpha'} (-1 + \sum_{n=1}^{\infty} \sum_{i=2}^p n a_n^{i\dagger} a_n^i + \sum_{m=1}^{\infty} \sum_{a=p+1}^d m a_m^{i\dagger} a_m^i). \quad (6.27)$$

The associated field is a Maxwell gauge field living on the brane. Is a fundamental result.

A  $D_p$ -brane has a Maxwell field living on its global volume

(6.28)

Like the Lorentz scalars on the brane. Consequently, a massless scalar field is obtained for each direction normal to the ramp  $D_p$ :

A  $D_p$ -brane has a massless scalar for each normal direction

(6.29)

### 6-3 Channels open between a parallel $D_p$ -brane

We will now consider the quantization of the chains opened by the notation to the extent between two parallel  $D_p$ -branes.

Two parallel branes of the same dimensionality have the same set of longitudinal coordinates and the same set of normal coordinates.

Recall that the value  $\bar{x}^a$  has normal coordinates specify the position of a  $D_p$ -brane. This time the first  $D_p$ -brane is located at  $\bar{x}^a = \bar{x}_1^a$  and the second at  $\bar{x}^a = \bar{x}_2^a$ . If  $\bar{x}_1^a = \bar{x}_2^a$  we says that the two  $D_p$ -branes wedge in space and are superimposed on each other, they are separated as shown in Figure 6.1. So what types of open strings this parallel  $D_p$ -brane configuration is supposed to be?

Indeed, there are four classes of different strings, each of which should be analyzed separately. The first two classes are composed of open strings that start and end on the same D-brane, these strings have already been studied and quantified in the previous section. The other two classes consist of ropes that begin on one brane and end on the other. They are stretched ropes. The strings that start at the first and end at the second are different from the strings that start at the second and end at the first.

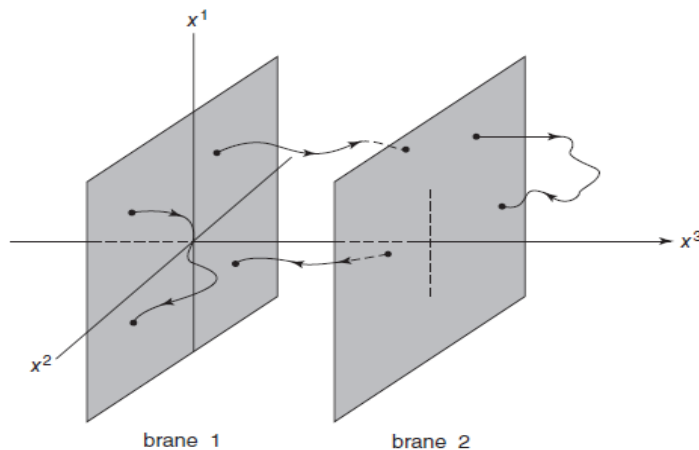

**Fig-6.1.** Two D2- parallel branes. Here  $x^1$  and  $x^2$  are longitudinal coordinates, and  $x^3$  is a normal coordinate. The positions of brane 1 and brane 2 are specified by the coordinates  $\bar{x}_1^3$  and  $\bar{x}_2^3$ , respectively. We show the four types of strings that this configuration supports.

These strings are oppositely oriented, and the orientation of a string (the direction of increase of  $\sigma$ ) is important. The load of a string changes sign when its orientation is reversed. The classes of open strings supported on a particular configuration of D-branes are called sectors. The quantum theory of open strings in the presence of two parallel  $D_p$ -branes has four sectors. Figure 6.1 shows a string for each of the four sectors.

Consider the sector of open strings that start at the first and end at the second. The coordinates of the strings NN  $X^+$ ,  $X^-$  and  $X^i$  are quantized as before, since the corresponding boundary conditions are always given by (6.5). On the other hand, for the strings DD, the coordinates with the boundary conditions (previously given by (6.4)) have become now

$$X^a(\tau, \sigma)|_{\sigma=0} = \bar{x}_1^a, \quad X^a(\tau, \sigma)|_{\sigma=\pi} = \bar{x}_2^a, \quad a = p + 1 \dots \dots d. \quad (6.38)$$

The solution of the wave equation subjected to these boundary conditions can be studied from (6.15) which already incorporates the boundary condition at  $\sigma = 0$ . In this case we simply change  $\bar{x}^a$  to  $\bar{x}_1^a$ :

$$X^a(\tau, \sigma) = \bar{x}_1^a + \frac{1}{2}(f^a(\tau + \sigma) - f^a(\tau - \sigma)). \quad (6.39)$$

The boundary condition at  $\sigma = \pi$  now gives us

$$f^a(\tau + \sigma) - f^a(\tau - \sigma) = 2(\bar{x}_2^a - \bar{x}_1^a), \quad (6.40)$$

Or equivalent,

$$f^a(u + 2\pi) - f^a(u) = 2(\bar{x}_2^a - \bar{x}_1^a) \quad (6.41)$$

This means that the derivative  $f^{a'}(u)$  is a periodic function of period  $2\pi$  and has an expansion of the type indicated in (6.17). Integration, the function  $f^a(u)$  has an expansion of the form

$$f^a(u) = f_0^a u + \sum_{n=1}^{\infty} (h_n^a \cos nu + g_n^a \sin nu). \quad (6.42)$$

The constant  $f_0^a$  is fixed by the boundary condition (15.41):

$$f_0^a = \frac{1}{\pi}(\bar{x}_2^a - \bar{x}_1^a). \quad (6.43)$$

Substitute  $f_0^a$  in (6.39), the computations are identical to those given in (6.19). This time we get

$$X^a(\tau, \sigma) = \bar{x}_1^a + (\bar{x}_2^a - \bar{x}_1^a) \frac{\sigma}{\pi} + \sum_{n=1}^{\infty} (f_n^a \cos n\tau + \bar{f}_n^a \sin n\tau) \sin n\sigma. \quad (6.44)$$

To describe the strings which extend from the second brane to the first brane, we are exchanged in the above equation for  $\bar{x}_1^a$  and  $\bar{x}_2^a$ . We can rewrite (6.44) in terms of oscillators, using (15.20) as a model:

$$X^a(\tau, \sigma) = \bar{x}_1^a + (\bar{x}_2^a - \bar{x}_1^a) \frac{\sigma}{\pi} + \sqrt{2\alpha'} \sum_{n \neq 0} \frac{1}{n} \alpha_n^a e^{-in\tau} \sin n\sigma. \quad (6.45)$$

The constants  $\bar{x}_1^a$  and  $\bar{x}_2^a$  do not become quantum operators because for the fixed  $D$ -branes as before, they are not parameters of the fluctuations of the open strings. Given the absence of

linear terms in  $\tau$ ; open strings have no average moments averaged in the directions  $x^a$ . The oscillators above are different from those we obtained when quantizing strings that start and end on the same  $D_p$ -brane. Oscillators in different sectors should not be confused. This time the ideals give

$$\dot{X}^a = -i\sqrt{2\alpha'} \sum_{n \in \mathbb{Z}} \alpha_n^a e^{-in\tau} \sin n\sigma, \quad X^{a'} = \sqrt{2\alpha'} \sum_{n \in \mathbb{Z}} \alpha_n^a e^{-in\tau} \cos n\sigma \quad (6.46)$$

Or

$$\sqrt{2\alpha'} \alpha_0^a = \frac{1}{\pi} (\bar{x}_2^a - \bar{x}_1^a). \quad (6.47)$$

Although the strings do not carry the impulse in the direction  $x^a$ , there is always a zero  $\alpha_0^a$  not null. There is no contradiction since the interpretation of  $\alpha_0$  requires that  $\alpha_0$  appear in  $\dot{X}$ . As you can see,  $\alpha_0^a$  appears in  $X^a$  but not in  $X^{a'}$ . A not null  $\alpha_0^a$  implies measurable strings:  $\alpha_0^a$  vanishes precisely when the D-branes coincide. Similar operators appear in the expansion of closed strings that revolve around compact dimensions.

The two derivatives of (6.46) combine and form

$$X^{a'} \pm \dot{X}^a = \sqrt{2\alpha'} \sum_{n \in \mathbb{Z}} \alpha_n^a e^{-in(\tau \pm \sigma)}. \quad (6.48)$$

This result shows that the oscillators satisfy the expected switching relationships. To compute the mass-squared operator we reconsider the equation (6.10). As before, we put  $I \rightarrow (i, a)$  and we define the subtraction constant equal to minus one, gives

$$2p^+ p^- = \frac{1}{\alpha'} \left( \alpha' p^i p^i + \frac{1}{2} \alpha_0^a \alpha_0^a + \sum_{n=1}^{\infty} [\alpha_{-n}^i \alpha_n^i + \alpha_{-n}^a \alpha_n^a] - 1 \right). \quad (6.49)$$

So we have

$$M^2 = 2p^+ p^- - p^i p^i = \frac{1}{2\alpha'} \alpha_0^a \alpha_0^a + \frac{1}{\alpha'} \left( \sum_{n=1}^{\infty} [\alpha_{-n}^i \alpha_n^i + \alpha_{-n}^a \alpha_n^a] - 1 \right) \quad (6.50)$$

Using the explicit value of  $\alpha_0^a$  to (6.47) we finally get

$$M^2 = \left( \frac{\bar{x}_2^a - \bar{x}_1^a}{2\pi\alpha'} \right)^2 + \frac{1}{\alpha'} (N^\perp - 1), \quad (6.51)$$

Or

$$N^\perp = \sum_{n=1}^{\infty} \sum_{i=2}^p n \alpha_n^{i\dagger} \alpha_n^i + \sum_{m=1}^{\infty} \sum_{a=p+1}^d m \alpha_m^{a\dagger} \alpha_m^a \quad (6.52)$$

Since the tension of the chord  $T_0 = \frac{1}{2\pi\alpha'}$ , this term is simply the square of the energy of a classical static chord stretched between the two D-branes. It is reasonable to find that the squared mass operator is modified by the addition of this constant. The constant disappears precisely when the branes coincide.

Now let's look at the fundamental states. In this configuration, the momentum tags of these states are the same for each sector:  $p^2$  and  $\vec{p}$ . To distinguish the different sectors, two additional integers  $[ij]$  are included as additional ground state labels, whose cache can be one or two. The first integer indicates the brane on which is the point  $\sigma = 0$  and the second integer

indicates the brane on which is the end point  $\sigma = \pi$ . In short, the strings opened in the sector  $[ij]$  extend from the brane  $i$  to the brane  $j$ . Fundamental states are written as  $| \downarrow p^+, \vec{p}; [ij] \rangle \downarrow$  and they are of four types:

$$|p^+, \vec{p}; [11]\rangle, \quad |p^+, \vec{p}; [22]\rangle, |p^+, \vec{p}; [12]\rangle, |p^+, \vec{p}; [21]\rangle. \quad (6.53)$$

The states of open strings in sector  $[ij]$  are constructed from oscillators acting on  $| \downarrow p^+, \vec{p}; [ij] \rangle \downarrow$ . The states take the form indicated in (6.31), except that the ground state is replaced by  $| \downarrow p^+, \vec{p}; [ij] \rangle \downarrow$  the oscillators in the four sectors are the same in number and type, but they are fundamentally different operators.

They can be labelled with labels  $[ij]$  for clarity, but this is rarely necessary because the basic states carry the sector tags.

Where do the fields corresponding to the  $[12]$  string characters live?

This question is hard to pin down. These are clearly dimensional  $(p + 1)$  fields, since the structure of state labels is the same as that for string states.

In some ways, the fields must live on both D-branes. Operationally, the fields are declared to live on a fixed  $(p + 1)$  space (not necessarily identified with one of the two D-branes), and are considered to have non-local interactions that reflect the fact that the D-branes are separated. The space-time interpretation of fields from stretched strings appears to require a new way of thinking, the basis of which can be provided by a mathematical branch called non-commutative geometry.

Just as we did for the brane alone, we will determine whether the states are scalars or vectors with respect to Lorentz symmetry with  $(p + 1)$  dimensional. The simplest states are the fundamental states:

$$|p^+, \vec{p}; [12]\rangle, \quad M^2 = -\frac{1}{\alpha'} + \left( \frac{\bar{x}_2^a - \bar{x}_1^a}{2\pi\alpha'} \right)^2 \quad (6.54)$$

If the separation between the branes disappears, these states are tachyon states of the usual mass-square. If the branes are separated, the squared mass has a positive contribution. In fact for the critical separation the fundamental states represent a scalar field without mass.

$$|\bar{x}_2^a - \bar{x}_1^a| = 2\pi\sqrt{\alpha'}, \quad (6.55)$$

For larger separations, the fundamental states represent a massive scalar field.

If the oscillator acting on the base states comes from a normal brane we have

$$a_1^{a\dagger} |p^+, \vec{p}; [12]\rangle, \quad a = p + 1 \dots \dots \dots d M^2 = \left( \frac{\bar{x}_2^a - \bar{x}_1^a}{2\pi\alpha'} \right)^2. \quad (6.56)$$

If the oscillator comes from a coordinate tangent to the brane we have

$$a_1^{a\dagger} |p^+, \vec{p}; [12]\rangle, \quad i = 2 \dots \dots \dots p M^2 = \left( \frac{\bar{x}_2^a - \bar{x}_1^a}{2\pi\alpha'} \right)^2. \quad (6.57)$$

For any moment, these are  $(p + 1) - 2 = p - 1$  massive states. In addition they carry  $p - 1$  massive states. In addition, they carry an index corresponding to the space-time  $(p + 1)$  dimensional.

We might think that these states form a massive gauge field of Maxwell, but that's not quite right.

## **Conclusion.**

- General relativity explains the world of the greatest objects.
- Quantum mechanics explains the world of smaller objects.
- String theory would appease the world of turbulent quantum mechanics to unite the two theories.
- String theory shows that everything in the universe is composed of strings
- If this theory is proven, we could do countless things that seemed science fiction.

# Appendix A

## The Newtonian limits

The assumption that gravitational effects are weak allows us to assume that the metric coefficients are close to those of the Minkowski metric  $\eta_{\mu\nu}$ , so we can write :

$$g_{\mu\nu} \approx \eta_{\mu\nu} + h_{\mu\nu} \quad (\text{A.1.1})$$

Where  $h_{\mu\nu} \ll 1$ , and we can choose to work to first order in  $h_{\mu\nu}$ . We can also suppose that the metric is not changing significantly with time, so  $h_{\mu\nu}$  is not a function of time.

We define the stress–energy tensor (2.4.9.5) :

$$T_{\mu\nu} = \rho u_\mu u_\nu + h_{\mu\nu} \quad (\text{A.1.2})$$

And we can write :

$$T = \sum_{\mu} T^{\mu}_{\mu} = \rho c^2 \quad (\text{A.1.3})$$

we define the Einstein field equation (2.4.1) :

$$R_{\mu\nu} - \frac{1}{2} g_{\mu\nu} R = k T_{\mu\nu} \quad (\text{A.1.4})$$

And we can write (A.1.4) in this form :

$$R_{\mu\nu} = -k \left( T_{\mu\nu} - \frac{1}{2} g_{\mu\nu} T \right) \quad (\text{A.1.5})$$

So the Einstein field equation can take the form :

$$R_{\mu\nu} = -k \left( \rho u_\mu u_\nu - \frac{1}{2} g_{\mu\nu} \rho c^2 \right) \quad (\text{A.1.6})$$

Substituting our simplified form of the metric (A.1.1) gives :

$$R_{\mu\nu} = -k \left( \rho u_\mu u_\nu - \frac{1}{2} (\eta_{\mu\nu} + h_{\mu\nu}) \rho c^2 \right) \quad (\text{A.1.7})$$

Examining the  $R_{00}$  term, and remembering that speeds are low, so  $u_0 = 0$  and that  $h_{\mu\nu} \ll 1$ , we see that :

$$R_{00} = -k \left( \rho c^2 - \frac{1}{2} \rho c^2 \right) = -k \frac{1}{2} \rho c^2 \quad (\text{A.1.8})$$

However, in the same limit, it can be shown from the definition of the Ricci tensor, we define the Ricci tensor (2.3.7.4) :

$$R_{00} = R_{0\mu 0}^{\lambda} = \partial_{\mu} \Gamma_{00}^{\lambda} - \partial_0 \Gamma_{\mu 0}^{\lambda} + \Gamma_{\mu\nu}^{\lambda} \Gamma_{00}^{\nu} - \Gamma_{0\nu}^{\lambda} \Gamma_{\mu 0}^{\nu} \quad (\text{A.1.9})$$

So we write :

$$R_{00} = - \sum_{i=1}^3 \frac{\partial \Gamma_{00}^i}{\partial x^i} \quad (\text{A. 1.10})$$

We define The Christoffel symbols(2.4.4.4) :

$$\Gamma_{00}^i = \frac{1}{2} \eta^{ki} (\partial_0 h_{\mu 0} + \partial_0 h_{0\nu} - \partial_k h_{00}) \quad (\text{A. 1.11})$$

So we write :

$$\Gamma_{00}^i = - \frac{1}{2} \sum_j \eta^{ij} \frac{\partial h_{00}}{\partial x^j} \quad (\text{A. 1.12})$$

and consequently :

$$R_{00} = \frac{1}{2} \sum_{i,j} \eta^{ij} \frac{\partial^2 h_{00}}{\partial x^i \partial x^j} = - \frac{1}{2} \nabla^2 h_{00} \quad (\text{A. 1.13})$$

Equating the two expressions that we now have for  $R_{00}$ , we see that in the Newtonian limit :

$$- \frac{1}{2} \nabla^2 h_{00} = -k \frac{1}{2} \rho c^2 \quad (\text{A. 1.14})$$

And so :

$$\nabla^2 h_{00} = k \rho c^2 \quad (\text{A. 1.15})$$

In another way , we know that :

$$- \frac{1}{2} \nabla h_{00} = \nabla \frac{\Phi(\mathbf{x})}{c^2} \quad (\text{A. 1.16})$$

So :

$$h_{00} = 2 \frac{\Phi}{c^2} \quad (\text{A. 1.17})$$

We can re-write (.....) :

$$\nabla^2 \Phi = k \frac{\rho c^4}{2} \quad (\text{A. 1.18})$$

We define the Poisson equation for the Newtonian potential (2.4.1.1) :

$$\nabla^2 \phi = 4\pi G \rho \quad (\text{A. 1.19})$$

provided that we identify :

$$k = \frac{8\pi G}{c^4} \quad (\text{A. 1.20})$$



# Appendix B

## General Relativity postulates

General relativity as is called Einstein's theory; it is a modern theory of space-time and gravitation . it makes it possible to reconcile two different important theorems : that of Newtonian gravitation and Special Relativity. This theory is complementary to the theory of Special Relativity , and it is based on some main ideas called postulates, they are as follows :

### B.1 The principle of equivalence

#### B.1.1 Weak equivalence principle

Within a sufficiently localized region of spacetime adjacent to a concentration of mass, the motion of bodies subject to gravitational effects alone cannot be distinguished by any experiment from the motion of bodies within a region of appropriate uniform acceleration.

#### B.1.1 Strong equivalence principle

Within a sufficiently localized region of spacetime adjacent to a concentration of mass, the physical behaviour of bodies cannot be distinguished by any experiment from the physical behaviour of bodies within a region of appropriate uniform acceleration.

### B.2 The principle of covariance

According to the principle of general covariance, the laws of physics should take the same form in all frames of reference. In practice this means that they should be expressed as balanced tensor relationships that are covariant under general coordinate transformations .

Legitimate algebraic operations involving tensors include scaling, addition and subtraction (provided that the types are identical), multiplication and contraction. The partial differentiation of a tensor does not generally produce another tensor, but the process of covariant differentiation does. This may be applied to a tensor of any rank and is exemplified by :

$$D_\nu T_k^\mu = \partial_\nu T_k^\mu + \Gamma_{\nu i}^\mu T_k^i - \Gamma_{\nu k}^i T_i^\mu \quad (B.2.1)$$

### **B.3 The principle of consistency**

The essence of Newtonian gravitation as a field theory is expressed in the Poisson equation :

$$\nabla^2\Phi = 4\pi G\rho \tag{B.3.1}$$

which relates a combination of second derivatives of the Newtonian gravitational potential  $\Phi$  to the mass density  $\rho$  that is the source of the Newtonian gravitational field. The Newtonian gravitational field  $g$  is related to  $\Phi$  by :

$$g = -\nabla\Phi \tag{B.3.2}$$

# List of references

## 01 Introduction:

- [1][https://www.brainyquote.com/quotes/j\\_robert\\_oppenheimer\\_752599](https://www.brainyquote.com/quotes/j_robert_oppenheimer_752599)
- [2]<http://www.azquotes.com/quote/255414>
- [3]J. C. Maxwell , Matter and Motion , Cambridge Library Collection , New York , 1888 , p9
- [4]Hugh D. Young, Roger A. Freedman , University Physics with Modern Physics , Pearson Addison Wesley ,12<sup>th</sup> edition , p1
- [5] T. Kuhn , The Copernican Revolution: Planetary Astronomy in the Development of Western Thought , Harvard University Press , 1985 , p1
- [6]G. Holton & Stephen G. Brush , Physics ; the Human Adventure: From Copernicus to Einstein and Beyond , Rutgers University Press , 4<sup>th</sup> edition , 2005 , p40
- [7] G. Holton & Stephen G. Brush , Physics ; the Human Adventure: From Copernicus to Einstein and Beyond , Rutgers University Press , 4<sup>th</sup> edition , 2005 , p52
- [8]Isaac Newton , Mathematical principles of natural philosophy , trans by Andrew motte , University of California press , London , 1966
- [9] E. Howard , An Introduction to the History of Mathematics , Holt, Rinehart and Winston, New York , 4<sup>th</sup> edition , 1976 , p305
- [10] The Industrial Revolution , <https://bit.ly/2HcFDt7>
- [11]<https://zapatopi.net/kelvin/quotes/>
- [12] C. Rovelli , Quantum Gravity , 2003 , p3 , <http://www.cpt.univ-mrs.fr/~rovelli>
- [13]L. Smolin , Three roads to Quantum Gravity , Basic Books , 2001 , p25
- [14] D. C. Moore , Trends in Quantum Gravity research , Nova Science Publishers , New York , 2006
- [15] L. Smolin , Loop Quantum Gravity , <https://bit.ly/2IUM20Z>
- [16]N. Bodendorfer , An elementary introduction to loop quantum gravity , 2016 , p6 , <https://arxiv.org/abs/1607.05129>
- [17] Simone Mercuri , Introduction to Loop Quantum Gravity , 2010 , p2 , <https://arxiv.org/abs/1001.1330v1>
- [18]N. Bodendorfer , An elementary introduction to loop quantum gravity , 2016 , p6 , <https://arxiv.org/abs/1607.05129>

## 02 General relativity :

[1][https://en.wikiquote.org/wiki/General\\_relativity](https://en.wikiquote.org/wiki/General_relativity)

[2] Steven Weinberg , Gravitation and Cosmology, pantheon books , New York , 1992 , p98

[3] S.W. Hawking and W. Isreal , General relativity , Cambridge university press , London , 1979 , p02

[4] L.D. Landau and E.M. Lifshitz , The classical theory of fields , Butterworth – Heinemann , 4<sup>th</sup> edition , 1989 , p245

[5] Alan Macdonald , Elementary general relativity , version 3.35 , p79

<http://www.faculty.luther.edu/~macdonal/EGR.pdf>

[6] M.P. Hobson G.P. Efstathioud and A.N. Lasenby , General relativity : an introduction for physicist , Cambridge university press , London , 2006 , p149

[7] K.H.K. GeeraseeWijesuriya , A Challenge to the Whole Physics World , Kindle Edition, 2016 , p87

[8] Alan Macdonald , Elementary general relativity , version 3.35 , p79

<mailto:macdonal@luther.edu>

[9] Gravitational waves detected 100 years after Einstein's prediction , <https://www.ligo.caltech.edu/news/ligo20160211>

[10] Norman K. Glendenning , Special and General relativity , Springer , Berkely, 1<sup>st</sup> edition , 2007 , p187

[11] B. Fauser J. Tolksdorf and E. Zeidler , Quantum Gravity : Mathematical Models and Experimental Bounds , Birkhauser , Berlin , 2007 , p01

[12] Isaac Newton , Mathematical principles of natural philosophy , trans by Andrew motte , University of California press , London , 1966 , p546

[13] Dna-Dennis , Newtons law universel gravitation ,

<https://commons.wikimedia.org/wiki/File:NewtonsLawOfUniversalGravitation.svg>

[14]Steven Weinberg , Dreams of a final theory , pantheon books , New York , 1992 , p11

[15] James B. Hartle , Gravity ; an introduction to Einstein's general relativity , Addison Wesley , San Francisco , 2003 , p04

[16] Vesselin Petkov , Space, Time, and Spacetime : Physical and Philosophical Implications of Minkowski's Unification of Space and Time , Springer , Heidelberg , 2010 , p31

[17] H. Nguyen-Schafer and J-P. Schmidt , Tensor Analysis and Elementary Differential Geometry for Physicists and Engineers , Springer , 2<sup>nd</sup> edition , Heidelberg , 2014 , p35

- [18] Joseph C. Kolecki , Foundations of Tensor Analysis for Students of Physics and Engineering With an Introduction to the Theory of Relativity , NASA/TP—2005-213115,p63, <https://go.nasa.gov/2rDAdS2>
- [19] Steven Weinberg , Gravitation and Cosmology , pantheon books , New York , 1992 , p91
- [20] M.P. Hobson G.P. Efstathioud and A.N. Lasenby , General relativity : an introduction for physicist , Cambridge university press , London , 2006 , p56
- [21] Eduardo W.V Chaves , Notes on continuum mechanics , CIMNE , Barcelona, 1<sup>st</sup> edition , 2013 , p 24–43
- [22] C.P. Dullemond and K. peters , Introduction on to tensors , 2014 , p 21–24 ,  
<http://www.ita.uni-heidelberg.de/~dullemond/lectures/tensor/tensor.pdf>
- [23] B. porat , A gentle introduction to tensors , 2014 , p 14 – 17 ,  
[https://www.esse.wustl.edu/~nehorai/Porat\\_A\\_Gentle\\_Introduction\\_to\\_Tensors\\_2014.pdf](https://www.esse.wustl.edu/~nehorai/Porat_A_Gentle_Introduction_to_Tensors_2014.pdf)
- [24] P. Grinfeld , Introduction to tensor analysis and the calculus of moving surfaces , Springer , New York , 2013 , p01
- [25] Ø. Grøn , Lecture Notes on the General Theory of Relativity : From Newton’s Attractive Gravity to the Repulsive Gravity of Vacuum Energy , Springer , Heidelberg , 2009 , p 66 – 69
- [26] S.M. Carroll , Lecture Notes on General Relativity , 1997 , p 47 – 48 ,  
<https://arxiv.org/abs/gr-qc/9712019>
- [27] K.N. Prasanna Kumar . B.S. Kiranagi and C.S. bagewadi , Einstein field equation and Heisenberg's principle of uncertainly the consummation of GTR and uncertainly principle , International Journal of Scientific and Research Publications , V2 , Issue 9 , September 2012 1 ISSN 2250-3153 , <http://www.ijsrp.org/research-paper-0912/ijsrp-p0954.pdf>
- [28] البنية الواسعة للزمان والمكان ، يوسف البناي ، ط1 ، 2016 ، ص 69 [youssefalbanay@gmail.com](mailto:youssefalbanay@gmail.com)
- [29] Robert J. A. Lambourne , Relativity, Gravitation and Cosmology , Cambridge University Press , 1<sup>st</sup> edition , 2010 , p107
- [30] Steven Weinberg , Gravitation and Cosmology, pantheon books , New York , 1992 , p 103 – 106
- [31] Malcolm Ludvigsen , General Relativity : A Geometric Approach , Cambridge University Press , 2004 , p 86 – 89
- [32] Norman K. Glendenning , Special and General relativity , Springer , Berkely, 1<sup>st</sup> edition , 2007 , p 40 – 41
- [34] David McMahon , Relativity Demystified , The McGraw-Hill Companies , 2006 , p65

- [35]RafaelFerraro , Einstein's Space-Time : An Introduction to Special and General Relativity , Springer , New York , 2007 , p256
- [36]Steven Weinberg , Gravitation and Cosmology, pantheon books , New York , 1992 , p 70 – 72
- [37]L.P. Hughston and K.P. Tod , An Introduction to General Relativity , Cambridge University Press , 1990 , p 86 – 89
- [38]A.Papapetrou , Lectures on General Relativity ,Reidel Publishing Company, Dordrecht , 1974 , p 26 – 27
- [39]Norman K. Glendenning , Special and General relativity , Springer , Berkely, 1<sup>st</sup> edition , 2007 , p36
- [40]Bernard Schutz , A First Course in General Relativity, Cambridge University Press , 1<sup>st</sup> edition , 1985 , p 167 – 170
- [41]Matthias Blau , Lecture Notes on General Relativity , 2017 , p 203 – 204 ,  
<http://www.blau.itp.unibe.ch/newlecturesGR.pdf>
- [42] John W. Norbury , General Relativity & cosmology for Undergraduates , 1997 , p38 ,  
<https://bit.ly/2rCYqJd>
- [43]Joseph C. Kolecki , Foundations of Tensor Analysis for Students of Physics and Engineering With an Introduction to the Theory of Relativity , NASA/TP—2005-213115,p60 ,  
<https://go.nasa.gov/2rDAdS2>
- [44]John W. Norbury , General Relativity & cosmology for Undergraduates , 1997 , p39 ,  
<https://bit.ly/2rCYqJd>
- [45]James Foster 1. David Nightingale , A Short Course in General Relativity , Springer , New York , 3<sup>rd</sup> edition , 2006 , p102
- [46] M.P. Hobson G.P. Efstathioud and A.N. Lasenby , General relativity : an introduction for physicist , Cambridge university press , London , 2006 , p158
- [47] Norman K. Glendenning , Special and General relativity , Springer , Berkely, 1<sup>st</sup> edition , 2007 , p 46 – 47
- [48]James Foster 1. David Nightingale , A Short Course in General Relativity , Springer , New York , 3<sup>rd</sup> edition , 2006 , p 104
- [49]Matthias Blau , Lecture Notes on General Relativity , 2017 , p209 ,  
<http://www.blau.itp.unibe.ch/newlecturesGR.pdf>
- [50]David McMahon , Relativity Demystified , The McGraw-Hill Companies , 2006 , p88
- [51] Matthias Blau , Lecture Notes on General Relativity , 2017 , p218 ,

<http://www.blau.itp.unibe.ch/newlecturesGR.pdf>

[52] Bernard Schutz , A First Course in General Relativity, Cambridge University Press , 1<sup>st</sup> edition , 1985 , p 174

[53] M.P. Hobson G.P. Efstathioud and A.N. Lasenby , General relativity : an introduction for physicist , Cambridge university press , London , 2006 , p162

[54] James Foster 1. David Nightingale , A Short Course in General Relativity , Springer , New York , 3<sup>rd</sup> edition , 2006 , p 99 – 101

[55] M.P. Hobson G.P. Efstathioud and A.N. Lasenby , General relativity : an introduction for physicist , Cambridge university press , London , 2006 , p179 – 181

[56] Norman K. Glendenning , Special and General relativity , Springer , Berkely, 1<sup>st</sup> edition , 2007 , p57

[57] Robert J. A. Lambourne , Relativity, Gravitation and Cosmology , Cambridge University Press , 1<sup>st</sup> edition , 2010 , p131

[58] David McMahon , Relativity Demystified , The McGraw-Hill Companies , 2006 , p155

[59] John C. Baez\_ and Emory F. Bunny , The Meaning of Einstein's Equation , 2006 , p1 , <https://arxiv.org/abs/gr-qc/0103044>

[60] C. Misner K. S. Thorne and J. A. Wheeler , Gravitation , W.H. Freeman and Company , san Francisco , 1973 , p916

[61] Benjamin Crowell , General Relativity , California , 2009 , p143 , <http://www.lightandmatter.com/genrel/genrel.pdf>

[62] Robert J. A. Lambourne , Relativity, Gravitation and Cosmology , Cambridge University Press , 1<sup>st</sup> edition , 2010 , p134

[63] T. Pyle , Massive Bodies Warp Spacetime ,

<https://www.ligo.caltech.edu/image/ligo20160211e>

[64] البنية الواسعة للزمان والمكان ، يوسف البناي ، ط1 ، 2016 ، ص 86 – 91 [youcssefalbanay@gmail.com](mailto:youcssefalbanay@gmail.com)

[65] Asaf Pe'er , Einstein's field equation , 2014 , p 1 – 3 ,

<http://www.physics.ucc.ie/apeer/PY4112/Einstein.pdf>

[66] Robert J. A. Lambourne , Relativity, Gravitation and Cosmology , Cambridge University Press , 1<sup>st</sup> edition , 2010 , p139

[67] Asaf Pe'er , Einstein's field equation , 2014 , p 6 ,

<http://www.physics.ucc.ie/apeer/PY4112/Einstein.pdf>

[68] <http://www.azquotes.com/quote/723301>

- [69]E. Bianchi, C. Rovelli , Why all these prejudices against a constant? , 2010 , p1 ,  
<https://arxiv.org/abs/1002.3966>
- [70]N. Straumann , General Relativity With Applications to Astrophysics , Springer , Heidelberg , 2004 , p147
- [71]David McMahon , Relativity Demystified , The McGraw-Hill Companies , 2006 , p204
- [72]A. Zee , Einstein Gravity in a Nutshell , Princeton University Press , New jersey , 2013 , p362
- [73]Robert J. A. Lambourne , Relativity, Gravitation and Cosmology , Cambridge University Press , 1<sup>st</sup> edition , 2010 , p 146 – 150
- [74]M.P. Hobson G.P. Efstathioud and A.N. Lasenby , General relativity : an introduction for physicist , Cambridge university press , London , 2006 , p 198 –201
- [75]Gerard 't Hooft , Introduction to General Relativity , 2012 , p 45 – 49 ,  
[http://www.phys.uu.nl/~thooft/lectures/genrel\\_2013.pdf](http://www.phys.uu.nl/~thooft/lectures/genrel_2013.pdf)
- [76]A.Papapetrou , Lectures on General Relativity ,Reidel Publishing Company, Dordrecht , 1974 , p 66 – 69
- [77]Robert J. A. Lambourne , Relativity, Gravitation and Cosmology , Cambridge University Press , 1<sup>st</sup> edition , 2010 , p 151 – 154
- [78]James B. Hartle , Gravity ; an introduction to Einstein's general relativity , Addison Wesley , San Francisco , 2003 , p189
- [79]AllenMcC , Flamm Paraboloid , <https://bit.ly/2jWvU0W>

### **03 Cosmology :**

- [1][https://www.goodreads.com/author/quotes/64309.Werner\\_Heisenberg](https://www.goodreads.com/author/quotes/64309.Werner_Heisenberg)
- [2] E. A. Tropp ; V. Ya. Frenkel and A. D. Chernin, Alexander A Friedmann : The Man who Made the Universe Expand , Cambridge University Press , New York , 1993 , p175
- [3]David McMahon , Relativity Demystified , The McGraw-Hill Companies , 2006 , p256
- [4]Asaf Pe'er , Cosmology : Part I , 2014 , p1 ,  
<http://www.physics.ucc.ie/apeer/PY4112/Einstein.pdf>
- [5]A.Papapetrou , Lectures on General Relativity ,Reidel Publishing Company, Dordrecht , 1974 , p 192
- [6] Norman K. Glendenning , Special and General relativity , Springer , Berkely, 1<sup>st</sup> edition , 2007 , p187



- [7] Robert J. A. Lambourne , Relativity, Gravitation and Cosmology , Cambridge University Press , 1<sup>st</sup> edition , 2010 , p234
- [8] Robert J. A. Lambourne , Relativity, Gravitation and Cosmology , Cambridge University Press , 1<sup>st</sup> edition , 2010 , p236
- [9] Steven Weinberg , Gravitation and Cosmology, pantheon books , New York , 1992 , p409
- [10] C. Misner K. S. Thorne and J. A. Wheeler , Gravitation , W.H. Freeman and Company , san Francisco , 1973 , p714
- [11] Asaf Pe'er , Cosmology : Part I , 2014 , p1 ,  
<http://www.physics.ucc.ie/apeer/PY4112/Einstein.pdf>
- [12] Robert J. A. Lambourne , Relativity, Gravitation and Cosmology , Cambridge University Press , 1<sup>st</sup> edition , 2010 , p243
- [13] Steven Weinberg , Gravitation and Cosmology, pantheon books , New York , 1992 , p412
- [14] James B. Hartle , Gravity ; an introduction to Einstein's general relativity , Addison Wesley, San Francisco , 2003 , p387
- [15] James Foster 1. David Nightingale , A Short Course in General Relativity , Springer , New York , 3<sup>rd</sup> edition , 2006 , p186 [16] Ta-Pei Cheng , Relativity, Gravitation and Cosmology : a basic introduction , Oxford University Press , 1<sup>st</sup> edition , New York , 2005 , p137
- [17] Alexander A. Friedmann , On the curvature of space , 1922 ,  
<https://archive.org/details/Tm-Ph-0003>
- [18] Matthias Blau , Lecture Notes on General Relativity , 2017 , p777 ,  
<http://www.blau.itp.unibe.ch/newlecturesGR.pdf>
- [19] S. P. Driver , PHYS3303 Observational Cosmology–lectures 5 , 2012 ,  
[http://www.simondriver.org/Teaching/PHYS3303/obs\\_cos\\_lecture5.pdf](http://www.simondriver.org/Teaching/PHYS3303/obs_cos_lecture5.pdf)
- [20] David McMahon , Relativity Demystified , The McGraw-Hill Companies , 2006 , p267
- [21] M.P. Hobson G.P. Efstathioud and A.N. Lasenby , General relativity : an introduction for physicist , Cambridge university press , London , 2006 , p402
- [22] K. Haven , 100 Greatest Science Discoveries of All Time , Libraries Unlimited, 1<sup>st</sup> edition , 2007 , p150
- [23] P. Coles , The Routledge Companion to the New Cosmology , Routledge , 2<sup>nd</sup> edition , 2015 , p202
- [24] Hubble Flow , <http://astronomy.swin.edu.au/cosmos/h/hubble+flow>

- [25] James B. Hartle , Gravity ; an introduction to Einstein's general relativity , Addison Wesley , San Francisco , 2003 , p352
- [26] Scientifics , Milky Way Cepheid Standards for Measuring Cosmic Distances and Application to Gaia DR2: Implications for the Hubble Constant , 2018 , p15  
[,https://arxiv.org/abs/1804.10655](https://arxiv.org/abs/1804.10655)
- [27] Brews Ohare , Hubble constant , <https://bit.ly/2kA7zOD>
- [28] Ta-Pei Cheng , Relativity, Gravitation and Cosmology : a basic introduction , Oxford University Press , 1<sup>st</sup> edition , New York , 2005 , p120
- [29] cosmology , <https://en.oxforddictionaries.com/definition/cosmology>
- [30] Big bang model , <https://www.britannica.com/science/big-bang-model>
- [31] E. L. Wright , Frequently Asked Questions in Cosmology  
[,http://www.astro.ucla.edu/~wright/cosmology\\_faq.html](http://www.astro.ucla.edu/~wright/cosmology_faq.html)
- [32] <https://bit.ly/1n0MirE>
- [33] Hoyle on the Radio: Creating the 'Big Bang' , <https://bit.ly/2LCARIE>
- [34] C. R. Lawrence , Planck 2015 Results , 2015 , p29 , <https://bit.ly/2LAXpye>
- [35] Malcolm Ludvigsen , General Relativity : A Geometric Approach , Cambridge University Press , 2004 , 187
- [36] P. J. E. Peebles and B. Ratra , The Cosmological Constant and Dark Energy , 2002 , p02 , <http://arxiv.org/abs/astro-ph/0207347v2>
- [37] <http://home.physics.ucla.edu/~arisaka/home/Particle/>

## **04 Loop quantum gravity :**

- [1]M. Sainato , Dr. MichioKaku on Wormholes; Entanglement and a Theory Of Everything , <https://bit.ly/2rP7pqL>
- [2] M. Bojowald , Canonical gravity and applications : cosmology ; black holes ; and quantum gravity , Cambridge University Press , New York , 1<sup>st</sup> edition , 2011 , p248
- [3]D. Oriti, Approaches to Quantum Gravity : Toward a New Understanding of Space ; Time and Matter , Cambridge University Press , New York , 2009
- [4]Dah-Wei Chiou , Loop Quantum Gravity , 2014 , p4 , <https://arxiv.org/abs/1412.4362v1>
- [5] L. Smolin , Loop Quantum Gravity , <https://bit.ly/2IUM20Z>
- [6]S. Hossenfelder , String Theory Meets Loop Quantum Gravity , 2016 , <https://bit.ly/2Fi3Iil>

- [7] C. Rovelli , Notes for a brief history of quantum gravity, 2001 , <https://arxiv.org/abs/gr-qc/0006061v3>
- [8]A. Ashtekar , Gravity and the Quantum , 2004 , <http://arxiv.org/abs/gr-qc/0410054v2>
- [9]T. Thiemann , Introduction To Modern Canonical Quantum General Relativity , 2001 , <https://arxiv.org/abs/gr-qc/0110034v1>
- [10]B. Jankuloski , Quantum Gravity , <https://bit.ly/2s0CHec>
- [11] D. Oriti, Approaches to Quantum Gravity : Toward a New Understanding of Space ; Time and Matter , Cambridge University Press , New York , 2009 , p8
- [12] C. Rovelli , Loop Quantum Gravity , 2003 , <https://bit.ly/2IAIHFV>
- [13] C. Rovelli , Quantum Gravity , 2003 , p3 , <http://www.cpt.univ-mrs.fr/~rovelli>
- [14]Dah-Wei Chiou , Loop Quantum Gravity , 2014 , p6 , <https://arxiv.org/abs/1412.4362v1>
- [15] B. Fauser J. Tolksdorf and E. Zeidler , Quantum Gravity : Mathematical Models and Experimental Bounds , Birkhauser , Berlin , 2007 , p01
- [16]D. Oriti, Approaches to Quantum Gravity : Toward a New Understanding of Space ; Time and Matter , Cambridge University Press , New York , 2009 , p235
- [17] L. Smolin , Three roads to Quantum Gravity , Basic Books , 2001 , p24
- [18] L. Smolin , Three roads to Quantum Gravity , Basic Books , 2001 , p25
- [19]H. Javadi , A new Definition of Graviton , 2014 , p2 , <https://bit.ly/2Iy5wJd>
- [20] Shlomo Barak , The Graviton , 2017 , p7 , <https://bit.ly/2rXbDwp>
- [21] C. Rovelli , Loop Quantum Gravity , 2003 , <https://bit.ly/2IAIHFV>
- [22] C. Rovelli , Quantum Gravity , 2003 , p10 , <http://www.cpt.univ-mrs.fr/~rovelli>
- [23] C. Fleischhack , Kinematical Uniqueness of Loop Quantum Gravity , 2015 , p1 , <https://arxiv.org/abs/1505.04404>
- [24] L. Smolin , Loop Quantum Gravity , <https://bit.ly/2IUM20Z>
- [25] C. Rovelli , Loop Quantum Gravity , 2003 , <https://bit.ly/2IAIHFV>
- [26]Abhay Ashtekar , New variables for classical and quantum gravity , 1986 ,<https://bit.ly/2ID5RKH>
- [27]C. Kiefer , Quantum Gravity , Oxford University Press , New York , 2<sup>nd</sup> edition , 2007 , p181
- [28]R. Gambini and J. Pullin , A First Course in Loop Quantum Gravity , Oxford University Press , New York , 2011 , p92
- [29]Stephen Wolfram , A New Kind of Science , Wolfram Media , 1<sup>st</sup> Edition , 2002 , 1055

- [30]C. Rovelli and L. Smolin , Spin networks and Quantum Gravity , 1995 , p12 , <https://arxiv.org/abs/gr-qc/9505006>
- [31]C. Rovelli , Quantum Gravity , 2003 , p21 , <http://www.cpt.univ-mrs.fr/~rovelli>
- [32]S. A. Major , A Spin network primer , 1999 , <http://arxiv.org/abs/gr-qc/9905020v2>
- [33]Markus Poessel , Spin network , <https://bit.ly/2J1C1yW>
- [34] C. Rovelli , Quantum Gravity , 2003 , p179 , <http://www.cpt.univ-mrs.fr/~rovelli>
- [35]C. Rovelli , Loop Quantum Gravity , 2003 , <https://bit.ly/2IAIHFV>
- [36]C. Rovelli , Quantum Gravity , 2003 , p18 , <http://www.cpt.univ-mrs.fr/~rovelli>
- [37] H. Nicolai and K. Peeters , Loop and spin foam quantum gravity : a brief guide for beginners , 2006 , <https://arxiv.org/abs/hep-th/0601129v2>
- [38]C. Rovelli , Quantum Gravity , 2003 , p231 , <http://www.cpt.univ-mrs.fr/~rovelli>
- [39]Dah-Wei Chiou , Loop Quantum Gravity , 2014 , p51 , <https://arxiv.org/abs/1412.4362v1>
- [40] Dah-Wei Chiou , Loop Quantum Gravity , 2014 , p51 , <https://arxiv.org/abs/1412.4362v1>
- [41] Dah-Wei Chiou , Loop Quantum Gravity , 2014 , p56 , <https://arxiv.org/abs/1412.4362v1>
- [42] J.A. Wheeler , Geons; Black Holes and Quantum Foam , W. W. Norton & Company , 2000 , p312
- [43] David McMahon , Relativity Demystified , The McGraw-Hill Companies , 2006 , p233
- [44]Robert J. A. Lambourne , Relativity, Gravitation and Cosmology , Cambridge University Press , 1<sup>st</sup> edition , 2010 , p171
- [45]Robert J. A. Lambourne , Relativity, Gravitation and Cosmology , Cambridge University Press , 1<sup>st</sup> edition , 2010 , p174
- [46] Flint Wild , What Is a Black Hole ? , <https://go.nasa.gov/2fJiVvJ>
- [47] Robert M. Wald , General Relativity , The university of Chicago press , London , 1984 , p305
- [48] Flint Wild , What Is a Black Hole ? , <https://go.nasa.gov/2fJiVvJ>
- [49][https://imagine.gsfc.nasa.gov/science/objects/black\\_holes1.html](https://imagine.gsfc.nasa.gov/science/objects/black_holes1.html)
- [50]Jean-Pierre Luminet , Black Holes: A General Introduction , 1998 , p19 , <https://arxiv.org/abs/astro-ph/9801252>
- [51]C. Misner K. S. Thorne and J. A. Wheeler , Gravitation , W.H. Freeman and Company , san Francisco , 1973 , p876
- [52] Jean-Pierre Luminet , Black Holes: A General Introduction , 1998 , p9

,<https://arxiv.org/abs/astro-ph/9801252>

[53] Robert J. A. Lambourne , Relativity, Gravitation and Cosmology , Cambridge University Press , 1<sup>st</sup> edition , 2010 , p176

[54] Alian r , BH LMC , [https://commons.wikimedia.org/wiki/File:BH\\_LMC.png](https://commons.wikimedia.org/wiki/File:BH_LMC.png)

## **05 String Theory:**

[1] B. Zwiebach: A First Course in String Theory, Cambridge Univ. Press 2009

[2] G. 't Hooft: Introduction to string theory 2004  
[www.phys.uu.nl/~thoof/lectures/stringnotes.pdf](http://www.phys.uu.nl/~thoof/lectures/stringnotes.pdf)

[3] Michael B Green, Michael B. Green, John H. Schwarz, Edward Witten Superstring Theory: Volume 1, Introduction, Cambridge Univ. Press 1988.

## **06 D-branes:**

[1] B. Zwiebach: A First Course in String Theory, Cambridge Univ. Press 2009

[2] G. 't Hooft: Introduction to string theory 2004  
[www.phys.uu.nl/~thoof/lectures/stringnotes.pdf](http://www.phys.uu.nl/~thoof/lectures/stringnotes.pdf)

[3] Michael B Green, Michael B. Green, John H. Schwarz, Edward Witten Superstring Theory: Volume 1, Introduction, Cambridge Univ. Press 1988.

## **Abstract**

In this memorandum, we given a short study of the cosmology, and we presented the different theories of quantum gravity as: loop quantum gravity (LQG) and string theory.

***Keywords:*** Gravitation, Loop quantum gravity, String theory.